

[54] SCANNING DEVICE FOR SCINTIGRAPHY
 [75] Inventor: Renato Casale, Rome, Italy
 [73] Assignee: Ital Elettronica S.p.A., Rome, Italy
 [22] Filed: July 5, 1972
 [21] Appl. No.: 269,009

[30] Foreign Application Priority Data
 July 28, 1971 Italy 51968/71

[52] U.S. Cl. 250/367, 250/363
 [51] Int. Cl. G01t 1/20
 [58] Field of Search 250/50, 60, 61.5, 71.5 S,
 250/363, 366, 367, 369

[56] References Cited
 UNITED STATES PATENTS
 3,428,805 2/1969 Donato et al. 250/71.5 S
 R26,014 5/1966 Stickney et al. 250/71.5 S

Primary Examiner—Archie R. Borchelt

[57] ABSTRACT
 A device for the scintigraphic scanning according to a horizontal plane, comprising:
 a. A support provided with two guides horizontally and longitudinally located, one of which is located in the upper part of the support, while the second guide

is located in the lower part of the support;
 b. A carriage, movable with respect to the support along the two guides, provided in its upper part, projecting above the support, with rolling means suitable to support and to cause to slide along its axis a support rod for the first detector, horizontally and transversely located, said carriage being further provided in its lower part with a recess with possible rolling means suitable to support and to cause to slide along its axis a second support rod for the second detector, said second rod being located parallel to the first rod and below it;
 c. One or two support rods for the detectors, the first of said rods being supported above the support in a sliding way along its axis, by the rolling means located in the upper part of the carriage, and the second rod if present is supported slidingly along its axis by the possible rolling means contained in the suitable recess which is provided in the lower part of the carriage;
 d. A vertical shaft supported by said carriage on which is mounted a toothed wheel for each rod, each toothed wheel engaging a positive drive belt or the like, which is connected to each said rod so that rotation of the shaft determines the simultaneous displacement of the two rods along their axes; and single motor means for driving said shaft during a scanning operation.

6 Claims, 5 Drawing Figures

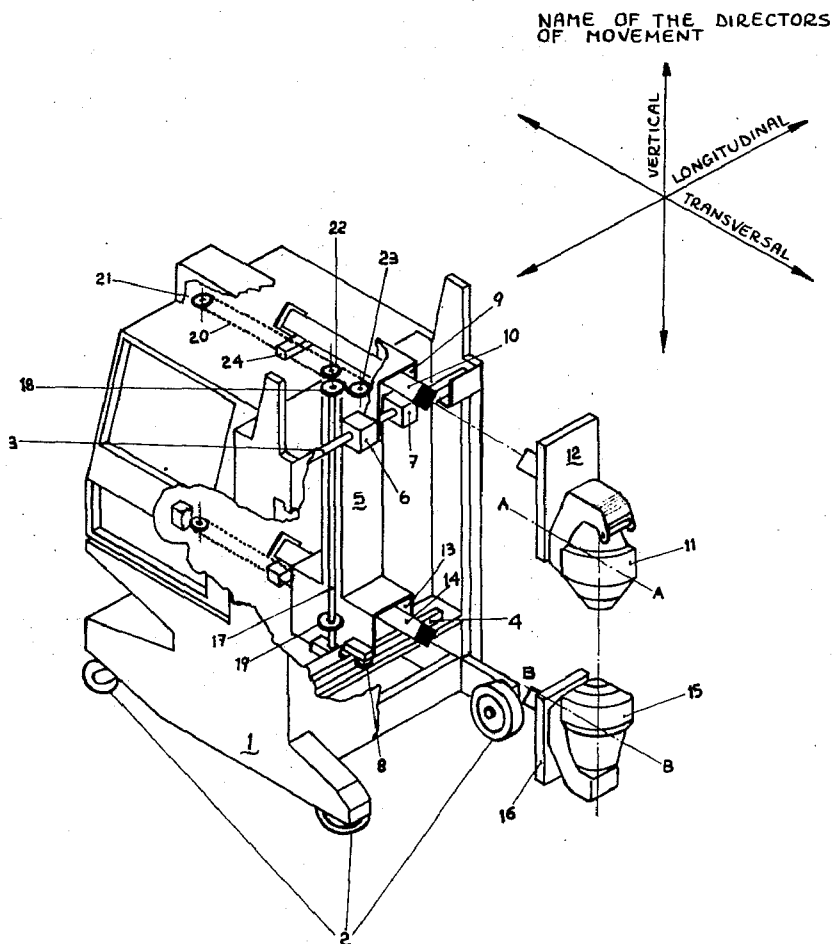

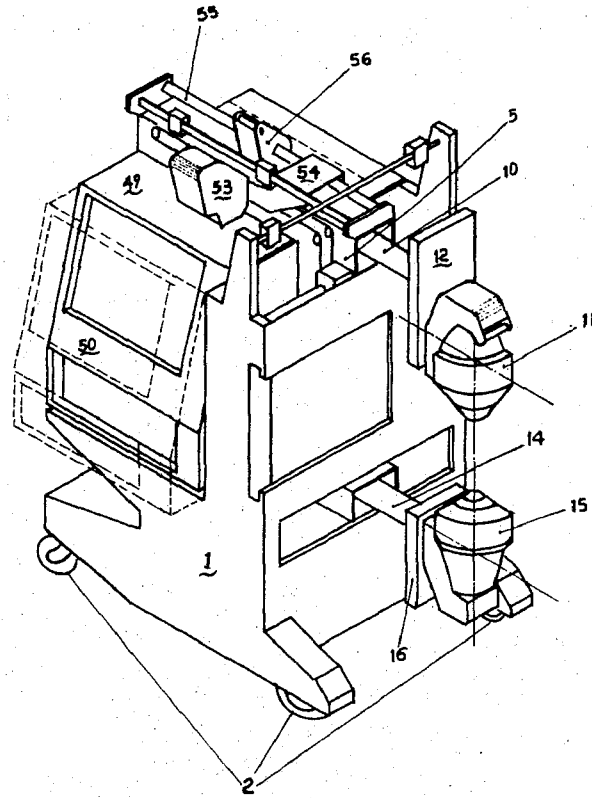

Fig. 1

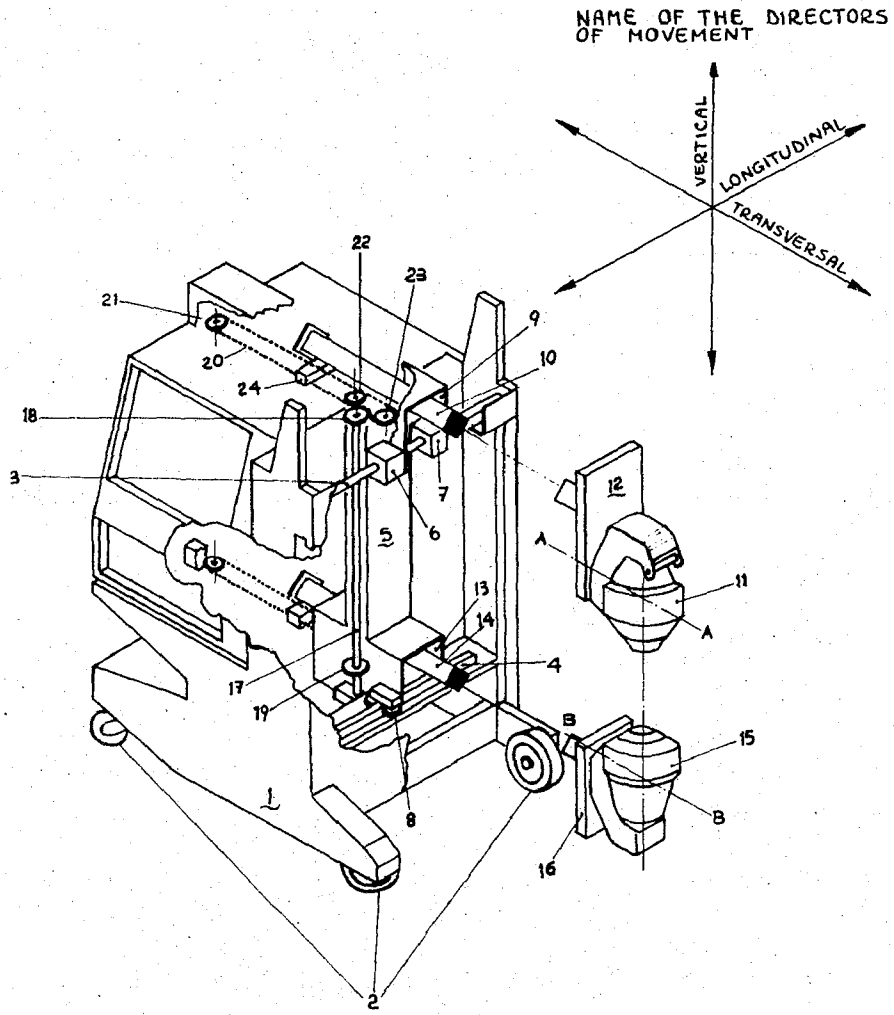
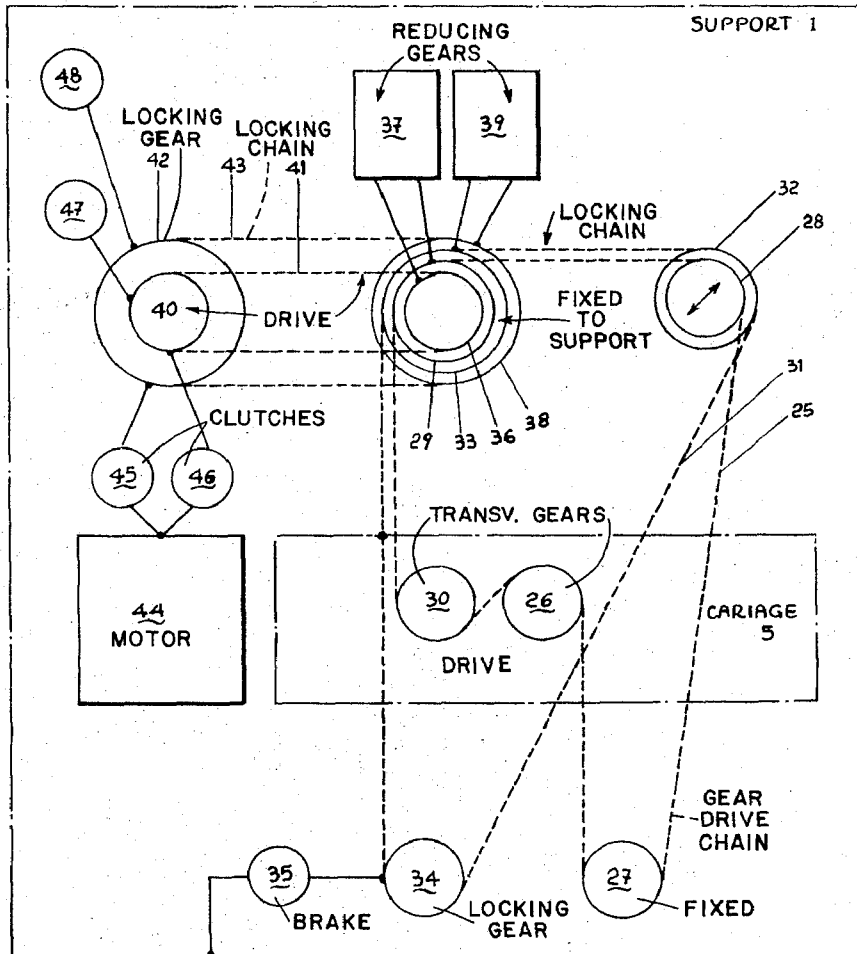

Fig. 2

Fig. 3



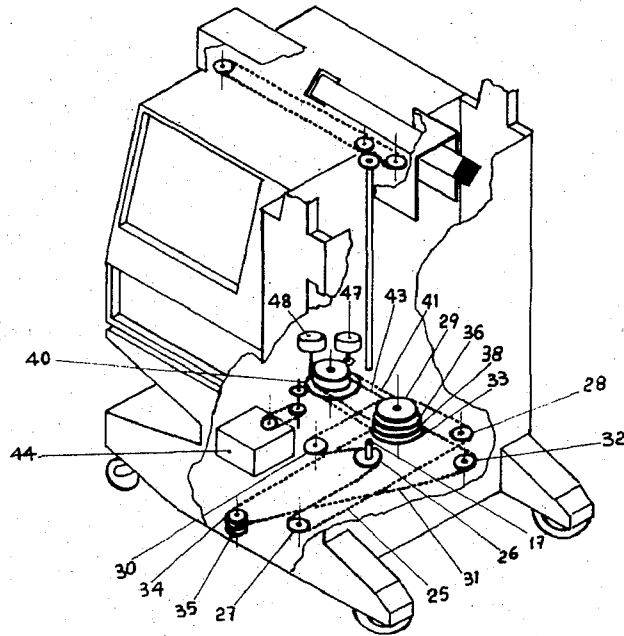

Fig. 4

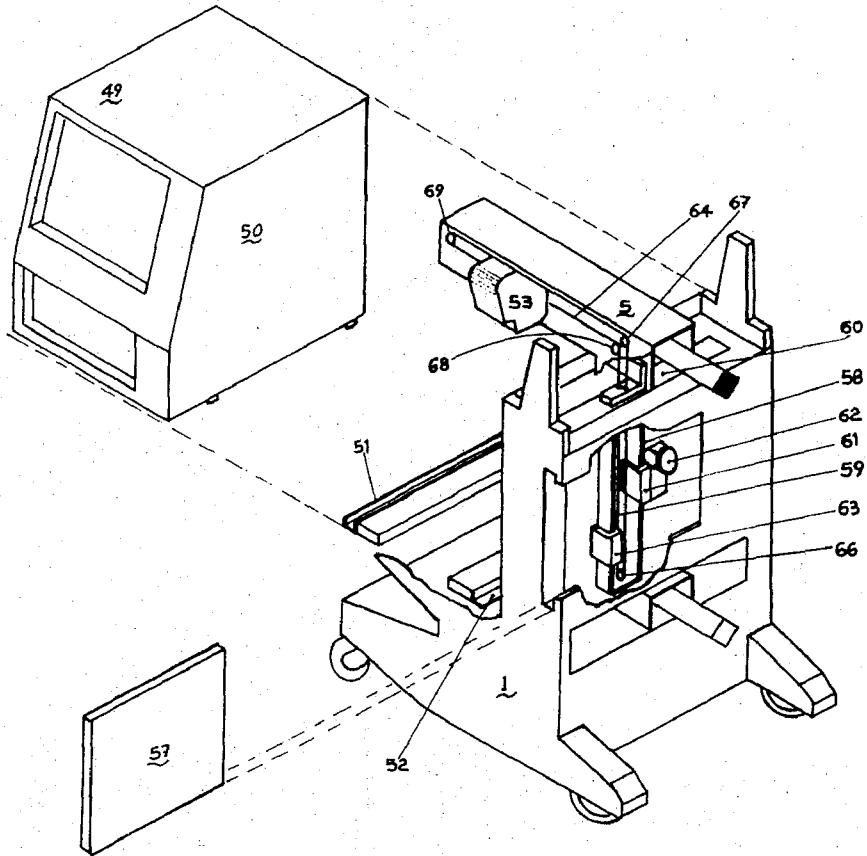

Fig. 5

SCANNING DEVICE FOR SCINTIGRAPHY

The present invention relates to a scanning device for scintigraphy according to a horizontal plane for detecting the distribution of radioisotopes in the patient's body. This scanning device although being capable of being equipped with either two detecting heads, or one detecting head, is provided with all the most advanced recording systems, and as it is may incorporate the fittings suitable to broadening and improving the use thereof, has, with respect to the known devices the advantages deriving from having extremely compact dimensions, so as to allow its easy transportation near the patient's bed, a remarkable manufacturing economy and the possibility of observing simultaneously during the scanning operation both the patient and the scintigraphy.

In order to reach the above cited advantages, a particular structure has been adopted including:

a. a support provided with two guides longitudinally and horizontally located, one of which is placed in the upper portion of the support, and the other in the lower part of the support itself.

b. a carriage, longitudinally movable with respect to the support along the two guides, being provided in its upper part, projecting above the support, with a recess with rolling means suitable to support a supporting rod for an upper detector, and to cause to slide along an axis cross-wise horizontally located, and provided also in its lower portion with a recess with rolling means suitable to support and to cause to slide along an axis a second supporting rod for a lower detector, said second rod being located parallel and beneath the first-mentioned supporting rod.

c. A supporting rod for each of the detectors, movably supported: the first rod above the support, and the second rod in its lower portion by said rolling means predisposed on the carriage in the suitable recesses.

d. A vertical shaft supported by said carriage on which is mounted a toothed wheel for each rod, each toothed wheel engaging a positive drive belt or the like, which is connected to each said rod so that rotation of the shaft determines the simultaneous displacement of the two rods along their axes; and single motor means for driving said shaft during a scanning operation.

In this structure, the second supporting rod for the detector, with the connected elements is not necessarily present; however according to this invention the recess in the carriage wherein can be located possibly in a second time all the elements necessary to provide the scintigraphic scanning device with a second detector is always present, embodying thus remarkable advantages of economy and compactness with respect to the two detector systems known up to now.

The above indicated advantages are attained also utilizing according to this invention, a single driving means, for both the movement of the carriage with respect to the support and the movement of the rod with respect to the carriage. This driving means consists essentially of a chain, a toothed belt or the like, hereinafter called driving chain, which passes around at least two gear rings with axes rigid with the support and around at least two gear rings with axes rigid with the carriage, the portions of said chain comprised between one ring the axis of which is rigid with the support, and a gear ring the axis of which is rigid with the carriage, having a path parallel to the direction of movement of

the carriage with respect to the support so that the total development of the path or length of the driving means or chain does not change when the carriage moves longitudinally or transversely with respect to the support. One of the gear rings having its axis rigid with the carriage is mounted on the vertical shaft supported by the carriage, the revolution of which determines the simultaneous sliding of the two rods along their axes transversely with respect to the carriage.

The driving chain is operated by a motor, optionally provided with a gearbox with electromechanical friction clutches which cause the gear ring the axis of which is rigid with the support to revolve and which hereinafter will be called driving gear. Two electromechanical clutches allow either the carriage to be locked with respect to the support, or the driving chain to be locked with respect to the carriage, determining thus the drive from the motor to the rods (when the carriage is stationary with respect to the support) or from the motor to the carriage (when the rods are stationary with respect to the carriage).

This system allows, besides, as it is obvious, of dispensing with one of the two reduction gears as ordinarily used for driving separately the transversal movement and the longitudinal movement, also of locating the motor-gearbox group in the lower part of the support where there is ample space, instead, as it has been made up to now, on the carriage, where it increases the encumbrance of the carriage itself.

The locking devices for the carriage with respect to the support, and of the driving chain with respect to the carriage, are embodied by means of a chain, toothed belt or the like, hereinafter called the locking chain, which winds around at least a pair of gears rings the axes of which are fixed on the support, said chain being fixed to the carriage in a portion parallel to the movement of the carriage with respect to the support. One of the gear rings, having its axis fixed as to the support hereinafter the locking gear ring, is co-axial and like the before said driving gear, rotated by the motor.

The locking device for the carriage with respect to the support is embodied by a device locking the locking chain with respect to the support and the locking device for the driving chain with respect to the carriage is embodied by locking to one another the two co-axial driving and locking gears.

The positioning device for the carriage with respect to the support and the possible device for detecting the position of the rod with respect to the carriage are connected to the driving and locking gear rings with the insertion between each of them and the associated gear ring of disconnectable motion reducer. The insertion of this reducer allows the reproduction in a reduced scale of scintigraphies the activity data for which the respective coordinates have been stored when the reducer is disconnected, in magnetic tape memories and the like, by well known means not herein described in detail.

In order to reach the mentioned advantages the plane of recordal on paper has been moved at the top of the entire scanning device, above the frames of the electronic metering and controlling circuits, and laterally to the carrier structure for the carriage and the associated guides, on which said carriage slides. Above the plane of recordal and parallel to both said plane and to the supporting rod of the detector, according to this invention a guide is supported by the carriage, and on said guide a slider slides guiding in turn the head for record-

ing on paper. Said slider is moved by the same chain or toothed belt which drives the upper rod, with the interposition of a device allowing an adjustable clearance for removing the scalloping on the recordal, and comprising a second auxiliary slider.

This system allows the positioning of the plane of recordal in a position suitable to the simultaneous observation of both the patient and of the scintigraphy during the scanning, and allows the application of the anti-scalloping device to the recordal system.

In order to reach the cited compactness advantages, also recourse has been made to the contrivance of supporting the plane of recordal on paper of the scintigraphy, by a structure independent with respect to the support and longitudinally movable with respect thereto. On said structure are also anchored the frames of the electronic metering and control circuits the front panels of which are inclined for ease of checking by the operator. The support is movable on wheels so as to be easily transported near the patient's bed. When the structure is withdrawn with respect to the support, the scanning device can easily pass through doors having a normal width, while when the structure is extended, it is possible to use on the recordal means the entire longitudinal stroke of the scanning device.

In order to embody the described advantages, moreover, the scintigraphic scanning device has also been provided with a photographic recorder with its film located in a vertical plane parallel to the direction of the movement of the carriage with respect to the support. In the dark chamber of said device extend, through a light tight seal passage, two vertical guides parallel to one another and to the plane of the film which are cantilever supported by the carriage. On one of said guides is mounted a slider supporting the projector of the photographic recorder, while on the other guide is mounted a second slider with a counter-weight for the projector. Both sliders are connected by a metal tape drive or the like to the slider guiding the recording head on paper, so that the movement of the projector and of its counter-weight will occur in opposite directions in order to prevent the tape drive from exerting on the slider of the head for recordal on paper, a lateral traction capable of disturbing the operation of the anti-scalloping device.

This system allows a very compact embodiment, in which a single anti-scalloping device acts on both the recordal systems and in which the plate carrying magazine of the photographic recorder is located in the top portion on one outer side of the scintigraphic scanning device for an easy replacement of the plates and an easy access to the projector for changing the slit.

For a more complete understanding of this invention, reference is made hereinafter to the attached drawings wherein:

FIG. 1 shows a perspective view of the system;

FIG. 2 shows the structural details of the support and of the carriage with the coupling device for the rods.

FIG. 3 shows a diagram of the driving device.

FIG. 4 shows the details of the mounting of the driving device.

FIG. 5 shows the details of the photographic recorder.

With reference to FIGS. 1 and 2, there has been shown the support 1 movable on the four wheels 2 and provided in its upper portion with the cylindrical guide 3, and in its lower part with the square cross section

guide 4. On said guides longitudinally slides the carriage 5 on the rolling means 6, 7 and 8.

In the upper part of the carriage 5 there is the recess 9 wherein transversely slides the rod 10 on suitable rolling means, not shown in the figure for sake of clearness. The rod 10 supports the detecting head 11 by the descending arm 12 which is vertically adjustable by the sliding movement of the coupling of the rod 10 along the arm 12 by means of a screw contained in the arm 10 (not shown).

The detecting head 11 is rotatable about an axis at the center of gravity A—A by means of a coupling (not shown) articulated on the arm 12.

In the lower part of the carriage 5 there is the recess 13 into which slides, parallel to the first cited rod 10, the rod 14 on suitable rolling means. The rod 14 supports the detecting head 15 by means of the ascending arm 16, which is vertically adjustable in a way similar to that of the arm 12. The detecting head 15 is rotatable about the axis B—B at the centers of gravity, like the head 11.

The movement in transverse direction of the two rods is synchronized by the shaft 17 on which are mounted the toothed wheels 18 and 19, said shaft being supported by the carriage by means of suitable bearings, not shown in the figure for sake of clearness.

The toothed wheel 18 engages the chain 20 wound about the toothed wheels 21, 22 and 23. The length of the chain 20 comprised between the toothed wheels 21 and 22 is parallel to the movement of the rod 10 and is connected to the latter by means of coupling 24. A similar device connects the rod 14 to the toothed wheel 19 so that the revolution of the shaft 17 determines the synchronous transverse movement of the rods 10 and 14.

In FIG. 3 the elements of the driving device have been diagrammatically shown, and the positioning of said elements in the scanning device can be observed in FIG. 4.

In these figures it is possible to remark the driving chain 25 which winds on the gear rings 26, 27, 28, 29 and 30, among which the toothed gears 26 and 30 have their axes rigid with the carriage and the gear rings 27, 28 and 29 have their axes rigid with the support 1. The gear ring 26 is mounted on the shaft 17 and accordingly its revolution determines the movement of simultaneous scanning of both rods in transverse direction. The portions of chain comprised between the gear rings 26 and 27 and between the gear rings 29 and 30 are parallel to the movement of the carriage with respect to the support, and therefore the total development or length of the path of the chain does not change when the carriage moves with respect to the support.

In FIGS. 3 and 4 it is possible to note also the locking chain 31 wounding about the gear rings 32, 33 and 34, the axes of which are parallel to the support said chain being parallel to the movement of the carriage with respect to the support in the portion comprised between the gear rings 33 and 34 and connected to the carriage in a point of said portion. The gear ring 33 is equal in periphery or number of teeth to the gear ring 29. The gear ring 34 can be locked to the support by means of the electromagnetic brake 35 which consequently has the effect of stopping the movement of the carriage with respect to the support.

The gear ring 29 is connected to the gear ring 36 by means of a optionally engageable reducer 37 and the

gear ring 33 is connected to the gear 38 equivalent to the gear 36, by means of the similar disengageable reducer 39.

The gear ring 36 is connected to the driving gear ring 40 by means of the auxiliary driving chain 41, while the gear 38 is connected to the locking gear ring 42, equivalent to the gear ring 40 by means of the auxiliary locking chain 43.

The driving gear ring 40 and the locking gear ring 42 are both connected to the gear box-motor unit 44 by means of two electro-magnetic clutches 45 and 46. When the clutches 45 and 46 are both locked, the carriage will be rigid with the driving chain through the locking chain and the associated auxiliary chains, and the rods 10 and 14 will be locked on the carriage. The motor of the group 44 can then, when the clutch 35 is free, impart a longitudinal movement to the carriage and the rods rigid therewith. When the clutch 45 is free and the clutches 35 and 46 are locked, the carriage will be locked with respect to the support, and the motor of the group 44 can impart to the rods a scanning movement in transverse direction, by means of the driving chains, of the shaft 17 and the chains engaging the toothed wheels 18 and 19. When the three electro-magnetic clutches 35, 45 and 46 are released it is possible to hand operate the positioning of the detectors.

To the driving gear ring 40 is connected the checking device 47 for the position of the rod with respect to the carriage, while to the locking gear ring 42 is connected the control device 48 for positioning the carriage with respect to the support. This contrivance connected to the use of the optionally engageable motion reducers between the driving chain and the driving gear ring, and between the locking chain and the locking gear ring, allows to store on a magnetic tape recorder the activities with the respective co-ordinates of a scintigraphy made as reducers of movement are disengaged, and of reproducing then the scintigraphy in reduced scale by inserting the reducers.

As it can be remarked from the FIGS. 1 and 5, the writing plane of the recorder on paper 49 makes part of a structure 50 autonomous with respect to the support 1, wherein are located under the writing plane the frames of the metering and controlling electronic circuits, with the panels inclined for an easier read-out and checking. This structure shown removed in FIG. 5 for sake of clearness, slides on the guides 51 and 52 and can reach the two positions shown in FIG. 1, in continuous line and in dotted line, respectively. In the withdrawn position, shown in continuous line, there is a reduced lateral encumbrance, which allows the scanning device to pass through the common doors, while in the extended structure, shown in the drawing in dotted line, it is possible to use on the paper recorder the entire scanning longitudinal stroke.

The writing head 53, as it can be noted in FIG. 1, is guided by the slider 54 sliding transversely along the guide 55, fixed to the slider 5. The slider 54 is driven by the same chain 20 (FIG. 2) which drives the rod 10, with the interposition of an adjustable clearance device for eliminating the scalloping, including the auxiliary slider 56.

In FIG. 5 there have been shown the details of the photographic recordal device, the sensitive plate 57 of which shown removed in the figure in order to render visible the inside of the device, is moved in vertical position, parallel to the two guides along which moves the

carriage. In the dark chamber of said recorder extend the two vertical guides 58 and 59, cantilever supported by the carriage through the light tight passage 60. Said guides are vertical and parallel to one another and to the plane of the film and thereon slide two sliders, the first of which 61 supports the projector 62, while the second slider 63 forms a counter-weight for the carriage with the projector. The sliders 61 and 63 are moved towards opposite directions by the metal tape 64 which is wound on the pulleys 66, 67, 68 and 69 with their axes rigid with the carriage, and which is fixed to the slider guiding the writing head on paper 53.

The guide 59 with the counterweight 63 are obviously necessary only if the weight of the carriage 61 and of the projector 62 is such as to transmit, in the absence of the counterweight, a lateral thrust to the slider guiding the head 53 sufficient to negatively affect the good operation of the device with adjustable clearance to compensate the scalloping.

The present invention has been illustrated and described on one preferred embodiment being however understood that constructive changes might be practically adopted without departing from the scope of the present industrial privilege.

Having thus described the present invention, what is claimed is:

1. A device for the scintigraphic scanning according to a horizontal plane, characterized in comprising:

a. A support provided with two linear guides horizontally and longitudinally located, one of which is located in the upper part of the support, while the second is located in the lower part of the support;

b. A carriage, movable with respect to the support along said guides, being provided in its upper part, projecting above the support, with rolling means for supporting and causing to slide along a linear axis thereof a support rod for supporting a supporting detector, being horizontally and transversely located, said carriage being further provided in its lower part with a recess for receiving rolling means for supporting and causing to slide along an axis thereof a second support rod for a second detector, said second rod being located parallel to the first rod and below it;

c. A pair of support rods for detectors, at least one support rod having thereon a radiation detector, the first of said rods being supported above the support in a sliding way along its axis, by the rolling means located in the upper part of the carriage, and the second rod supported slidingly along its axis by rolling means contained in a recess provided in the lower part of the carriage;

d. A vertical shaft supported by said carriage on which is mounted a toothed wheel for each rod, each toothed wheel engaging a positive drive chain or the like, which is connected to each said rod so that the rotation of the shaft determines the simultaneous displacement of the two rods along their axes; and single motor means for driving both said shaft and carriage during a scanning operation.

2. A scintigraphic scanning device as claimed in claim 1, characterized in that it comprises:

a. A driving unit for both the rod and the carriage consisting essentially of a positive drive chain or the like, which is wound on at least two gear rings the axes of which are rigid with the support, and about at least two gear rings the axes of which are

rigid with the carriage, the portions comprised between one gear ring with its axis rigid with the support and a gear ring with its axis rigid with the carriage, have a path parallel to the direction of movement of the carriage with respect to the support, so that the total length of the path of the chain will not change when the carriage moves with respect to the support, one of the gear rings having an axis rigid with the carriage being mounted on the vertical shaft supported by the carriage the rotation of which determines the simultaneous sliding of the rods with respect to the carriage;

b. Two slidably locking devices for locking at will the carriage with respect to the support and the chain with respect to the carriage, and a motor which rotates one of said gear rings having its axis rigid with the support, being a driving gear ring, said selectively locking of said device being operative to cause said motor to impart a transverse scanning movement to the rods and a longitudinal scanning movement to the carriage, according to which thereof is locked.

3. A scintigraphic scanning device as claimed in claim 2, characterized in that it comprises:

a. Means for locking the carriage with respect to the support and the driving chain with respect to the carriage, said means comprising a chain or the like which is wound on at least two gear rings the shafts of which are rigidly oriented to the support, said chain being fixed to the carriage and including a portion movable parallel to the movement of the carriage with respect to the support;

b. One of the gear rings, with its shaft rigidly oriented to the support, being a locking gear, co-axial and of equivalent dimensions to said driving gear, for actuation by the driving chain;

c. Said locking device for locking the carriage with respect to the support comprising a device locking

the locking chain with respect to the support, and said locking device for the driving chain with respect to the carriage, being connected to lock to one another the two driving and locking gear rings.

4. A scintigraphic scanning device as claimed in claim 3, wherein said drive chain for positioning the carriage with respect to the support, further including means for detecting the position of the rod with respect to the carriage being connected to the locking gear ring, and to the driving gear ring, respectively, and including a motion reduction means between each of them and the associated chain for changing scale factors in a recording of scanned data.

5. A scintigraphic scanning device as claimed in claim 4, including recording means having the plane of recordal of the scintigraphy horizontally located above the support structure and laterally with respect to said support rods for the carriage wherein said carriage supports a guide on which slides a first slider driving the recording head; said slider being coupled for motion to the same portion of said chain providing for the transverse displacement of the upper rod.

6. A scintigraphic scanning device as claimed in claim 1, further comprising a photographic recorder including a film located on a plane vertical and parallel to the direction of said two guides along which the carriage moves within a dark chamber having two vertical guides extending thereinto through a light tight passage, parallel to the plane of the film, a cantilever arm supported by the carriage; one of last said guides supporting a second slider for supporting a projector of the photographic recorder, while the other last said guide carries a third slider comprising a counter-weight for the projector inter-connected therewith for movement of the projector and of its counterweight in opposite senses.

* * * * *

40

45

50

55

60

65