



# Fermi National Accelerator Laboratory

FERMILAB-Conf-82/31-EXP  
2020.000  
2022.000

## THE DUMAND ARRAY DATA ACQUISITION SYSTEM\*

A. E. Brenner and D. Theriot  
Fermi National Accelerator Laboratory,  
Batavia, Illinois 60510 USA

and

W. D. Dau  
Institute fur Kernphysik, Kiel 23, West Germany

and

B. D. Geelhood  
Naval Ocean Systems Center, San Diego, California 92152 USA

and

F. Harris, J. G. Learned and V. Stenger  
Hawaii DUMAND Center, Honolulu, Hawaii 96822 USA

and

R. March  
University of Wisconsin, Madison, Wisconsin 53706 USA

and

C. Roos  
Vanderbilt University, Nashville, Tennessee 37315 USA

and

E. Shumard  
University of Michigan, Ann Arbor, Michigan 48104 USA

April 1982

\*Submitted to the DUMAND Conference, University of Hawaii, Honolulu, Hawaii, February 8-14, 1982.

THE DUMAND ARRAY DATA ACQUISITION SYSTEM

A. E. Brenner and D. Theriot  
Fermi National Accelerator Laboratory, Batavia, IL 60510

and

W. D. Dau  
Institute fur Kernphysik, Kiel 23, West Germany

and

B. D. Geelhood  
Naval Ocean Systems Center, San Diego, CA 92152

and

F. Harris, J. G. Learned and V. Stenger  
Hawaii DUMAND Center, Honolulu, HI 96822

and

R. March  
University of Wisconsin, Madison, WI 53706

and

C. Roos  
Vanderbilt University, Nashville, TN 37215

and

E. Shumard  
University of Michigan, Ann Arbor, MI 48104

ABSTRACT

An overall data acquisition approach for DUMAND is described. The scheme assumes one array to shore optical fiber transmission line for each string of the array. The basic event sampling period is  $\sim 13 \mu\text{sec}$ . All potentially interesting data is transmitted to shore where the major processing is performed.

## INTRODUCTION

A number of papers have been published describing possible DUMAND data acquisition and signal processing systems. Papers on this subject include in the DUMAND 1980 workshop papers by Akerlof, March, Snow and Theriot, (1) and by Cowen, Gilbert and Redfern.(2) Additional papers appear in the 1980 DUMAND Signal Processing Workshop Proceedings by Brenner, Theriot and March,(3) by Wilkins,(4) and by Akerlof.(5)

These earlier papers were all written within the context of the very large array originally suggested for DUMAND. The 1981 Standard Array, currently under study,(6) is appreciably smaller and consists of six planes, each with six strings of 21 detector elements each, for a total of 756 detector elements. The interplane and interstring distances are each 50 meters, and the detectors along each string are spaced at 25 meter intervals. This detector, appreciably more than an order of magnitude smaller than the earlier detector, simplifies enormously the signal processing apparatus associated with the array. Furthermore, the almost assured possibility of using a multiple fiber optics cable to connect the array to shore all but guarantees the possibility of transmitting almost all conceivably possible useful data to shore. This overall concept further simplifies or minimizes the amount of electronics that must be placed in situ at the array on the ocean bottom.

In this paper, a scheme which takes advantage of these factors will be described in some detail. A number of options will also be discussed so that as the details of the system are developed, both from cost and reliability point of view, and as the real experimental data rates become better known,(7) the various possible compromises can be studied and evaluated.

## OVERVIEW

For purposes of deployment, it appears that it may be desirable to deploy the detector in a number of sub-units. Although there are a number of possible such sub-units under discussion(8,9), for the purposes of this paper it is assumed that the deployed sub-unit will consist of one plane, i.e., six strings of 21 detectors each. Therefore, there may be an advantage, from a signal processing point view, to maintain each plane as a separate entity. Furthermore, so as to minimize the risk of or the consequences of failure, the desirable goal is to minimize to the extent that it is possible all electronics which cannot be placed either separately in each detector sphere or at the on-shore receiver station.

This gives rise to an electronics package which places in each detector sphere the PMT, DC to DC high and low voltage power converters, the analog to digital converters or at least an analog to time converter, and the necessary monitoring and control circuitry. A single optical fiber connects each detector with either a string or a (topologically equivalent) plane electronics module at the ocean bottom. A second cable for DC power distribution and multiplexed control I/O (half or full-duplex at a relatively slow standard communications rate) feeds each string with each detector teed off from a single power cable along the string.

In the string or plane electronics module, the final digitization and timing information for each detector is merged together, and all of the information for each detector associated with a single string is time division multiplexed (i.e., the position in the data stream indicates the module number) for transmission to shore on a single high-speed fiber optics link. Here it is assumed that each separate string will have its own fiber optics link.

The necessary clocking information must be good to approximately 10 nanoseconds to insure adequate timing information for tracking of single muons. This is no easy feat to accomplish across the whole detector. The concept here is to do all timing in the string or plane processor with no precision timing information being transmitted to each separate detector module. The availability of the clock signal requires one more fiber optics line (or the duplexing of the data lines) between the plane module and the shore station.

Redundancies aside, the cable connecting each plane to shore will have seven data optical fibers, one for each of the six strings in the plane and one for clocking information, all bundled together in one cable. The cable sheath carries the necessary DC power to the plane module, where it is then fanned out to each string. Each of the detectors receive power by a tee onto this line. The ocean serves as the ground return. A number of studies<sup>(10,11)</sup> have demonstrated the practicality of this approach. The power line is also used as a half or full-duplex communications link to each detector for control and monitoring purposes.

An overall diagram of one plane of the system is given in Fig. 1. This figure shows 24 modules in each string. It will be assumed from hereon that each string will contain three additional modules containing instrumentation for ancillary experiments. No further discussion of these modules will be given here, except for the tacit assumption that the data from these modules is time multiplexed onto the string data optical fiber in a manner identical to that of the 21 primary array detector modules.

## DETECTOR MODULE

It is desired to collect as much information as is possible from each detector module. Ideally, the thresholds should be set at one photo-electron (P.E.) so as to be sensitive to as many detector hits by Cerenkov radiation as possible. This gives rise to one major complication; namely, the high background  $K^{40}$  beta decay rate. The one characteristic of the muon radiation is that one is assured of time coincidences with neighboring detectors as the muon passes through the detector volume. More globally, one expects corrected time coincidences with a number of detectors defining the muon trajectory. The extent to which this information can be used in defining physics useful events will be discussed in a later section.

Another approach to distinguish  $K^{40}$  background radiation from proper triggers is to use a segmented photomultiplier tube<sup>(12)</sup> or equivalently two or more photomultipliers with requirements for local (i.e., within one detector module) coincidences. Since segmented tubes are not yet demonstrably available on a production basis, and since the use of multiple PMT's in each detector both complicates the design of the detector and is more expensive, it is assumed for the further purposes of this paper that a single, large 16 inch PMT will be used. A much more stringent trigger with no loss of efficiency would be possible if the so-called "smart" PMT or multiple PMT detectors could be available. If a "smart" PMT is used, the only significant additional information to be recorded is a flag bit indicating a multi-segment detection.

Each detector module is housed in a standard 17 inch (16" I.D.) Benthos<sup>(13)</sup> sphere. The sphere has one penetration pair for the DC power source into this module. This power line also carries a superimposed full or half duplex bi-directional communication link using a standard RS232 protocol at 4.8K or 9.6K baud. As indicated earlier, a single power line distributes power for the whole string and is teed off for each module penetration. In addition at each detector, there is a single detector module optical fiber cable which terminates on the outside of the sphere for high speed signal transmission from the detector module to the multiplexing logic in the string or plane module at the bottom of the string. The coupling to this fiber optics link is made with the use of a developing technology which allows transmission through the glass sphere from inside to outside without physical penetration of the sphere. See Fig. 2 for the overall detector module arrangement.

As can be seen from the Figure, the phototube fills much of the volume of the sphere. Other elements in the detector volume include the two power DC to DC power converters, one for logic and the other the PMT high voltage. These are both program adjustable. The PMT output signal feeds a program adjustable

discriminator. Those signals which pass the discriminator threshold are time converted by a signal-over-threshold conversion such that the leading edge of the time pulse defines the time of arrival of the signal at that detector and the length of the pulse is related to the total charge of the signal. For this detector time coded signal, a non-linear function may be desirable, e.g., a logarithm, bimodal or some other functional dependence, which would adequately handle the amplitude, range and resolution required. Typically, the length of the time coded pulse will range from a minimum of 20 or 30 nanoseconds to a maximum of  $\sim 2$  microseconds. The time coded pulse is transmitted on the detector module optical fiber to the string module on the ocean bottom. A block diagram of the detector module electronics is shown in Fig. 3.

Some logic must be included in the detector module to accomplish changes in discrimination level and high voltage that will be commanded from the shore. A number of monitoring functions, including read back of the set voltages, humidity, temperature, average current utilized are some of the parameters that will be monitored at a low duty cycle. Furthermore, certain control functions such as turning off the detector or entering test mode must also be implemented in the detector module. The most natural way of accomplishing these and similar functions while still leaving open the possibilities of yet additional functions to be implemented as experience is gained, especially during the testing period, is with the use of a standard microprocessor. These functions or tasks can all be implemented with a small 8-bit CMOS microprocessor and RAM memory. An 8080 or similar processor would do the job admirably.

#### STRING/PLANE ELECTRONICS MODULES

The detector module optical fibers from each of the detectors on a single string are brought together at the bottom of the detector array into a single module labeled the string electronics module. Although the details of the physical arrangement of the six string electronics modules should be determined by deployment considerations, one obvious embodiment uses one vessel to house all six string modules for a single plane, as is shown in Fig. 1. For the purposes of this paper, we will assume this configuration, although any number of topologically equivalent configurations are possible. A block diagram of the overall logic implemented in the string module is given in Fig. 4.

The string module receives the primary transmission line DC high voltage which is carried by the array-to-shore transmission cable. Here the power is converted to a lower voltage and distributed to the detectors on that string. The optical cable for the transmission of data from that string to shore terminates in the string module as does the fiber optics cable carrying the primary 10 nanosecond clocking signal from shore.

In the simplest version of the string module, the pulse width coded signals from each detector feed individual circuits which make the necessary conversion to clock time and pulse amplitude. The plane module maintains the current time for the plane by incrementing a clock scaler for each of the clock pulses entering the module. On the arrival of a detector module signal, the leading edge of that signal strobes the state of the clock scaler into one field of an event register associated with that detector. At the same time, a gate is opened which allows a previously zeroed amplitude scaler to start counting clock pulses representing the coded analog signal. When the pulse from the detector terminates, the gate is closed, and the state of the amplitude scaler is now strobed into a second field of the event register. This now represents the coded amplitude value of the pulse. Twelve bits for the time and ten bits (including one for overflow) for the amplitude fields of the event register should cover the needs well. In order to avoid the usual complications of strobing scalers into registers with the possibilities of catching a transition, any one of the usual techniques of a clocked strobe or a Gray coded scaler scheme could be used. Two additional bits are required in the event register for a locally generated parity bit and a flag bit. Additional flag bits may be defined as required, but it is desirable to maintain the data word as an integral number of standard 8-bit bytes. Once the event register is filled, it is strobed into a small ( $\sqrt{2}$  words) FIFO buffer.

The contents of the event FIFO buffer(14) are transmitted to shore when the next appropriate time slice for this detector is available in the transmission stream to shore. The cycle time for the transmission of data from every detector in all strings is approximately once every thirteen microseconds. Since the event FIFO buffer contains two (or more) words, during the waiting period for the next transmission cycle one (or more) additional event(s) in each detector may be digitized in the event register. This second event is then transmitted to the event FIFO buffer. If both (all) levels of the FIFO buffer are already filled, when the next event arrives at the string module a comparison is made, and if the current "analog" data in the register is larger than the previous entries in the buffer, the new data then replaces the old data; otherwise, the new data is discarded. Thus, typically in a single 13 microsecond cycle period, up to two separate digitized signals may be stacked. If more than two appear during that time window after the first signal, the largest amplitude signal that comes during that time window is the one that is saved.

It is expected that at best the average counting rate in each detector will be approximately one count every 10 microseconds. Thus, on the average about 1.3 hits will actually be recorded during this time interval. In fact, the singles rates may be appreciably higher, giving rise to a number of hits in each

transmission period. Also, for an 9-bit maximum amplitude, using the 10 nanosecond clocking digitizing signal, the peak maximum time required to digitize the peak amplitude will be  $\sim 5$  microseconds. During the 5 microseconds maximum time required for digitization, any other signal from the detector is unavailable. On the other hand, pulses from background K40 events will have low pulse heights giving rise to an "analog" pulse lasting only  $\sim 30$ -100 nanoseconds. A large pulse following one of these in short order will be discernible with little dead time, and with the logic described above such a signal will replace the lower amplitude signal in the comparison process if the buffers are filled.

It is highly desirable to preserve information defining the shape of every photomultiplier pulse. A number of methods for accomplishing this end have been considered. The amplitude of the PMT pulse may be flash encoded<sup>(15)</sup> at a number of different times, thereby defining the shape of the phototube signal. The value of each of the flash encoded signals would then be transmitted from the detector to the string module as a sequence of pulses in rapid succession. This approach complicates the electronics and data acquisition system, insofar as each detector must now have the necessary flash encoding logic and several times more information must be transmitted to shore adding some dead time to the system. Furthermore, the resolution from each flash encoder would necessarily be reduced from the 8 bits to 5 or 6 bits for each amplitude encoding. Such an approach will certainly increase the cost of the detector modules. Another, more attractive method to contain this information would include constructing one additional value representing a second moment or its equivalent of the pulse shape and transmitting this information in tandem with the integrated pulse value.

The string module, therefore, contains relatively simple parallel logic one for each separate detector module. Signals from all of these modules are time slot multiplexed onto the single data transmission optical fiber which leaves the module and returns the signal stream to shore. All strings operate similarly, each feeding its own fiber optics line.

At the ocean bottom, in the plane module the six single fiber optics lines from each of the string detectors are coalesced into a single multi-strand fiber optics cable which goes to shore. Here also resides the primary DC to DC converter which transforms the transmission line DC voltage to the local distribution power which is then fed to each of the string modules. Also, the master clock scaler for the plane is in the plane module.

The details of the mechanical and housing arrangement of the string electronics modules and the plane module associated with a single plane are open questions to be studied and decided upon in the light of deep ocean engineering technology. It might very



well be that each string module is in a vessel of its own, physically located at the bottom of each string. In that case, the plane multiplexor could be an extension of the first physical string module vessel. Thus, in this case for each plane, there are actually six separate vessels one serving both the first string and also the plane electronics module functions. The adoption of this or any other topologically equivalent approach does not in any way affect the logical description of the data acquisition and signal processing procedures. Thus, all processing could be performed in a single plane module.

#### THE LIMITED COINCIDENCE OPTION

One very important option to be considered in the design of the string module electronics is the use of a limited coincidence method, dubbed "Charley's Ruse," after a suggestion<sup>(16)</sup> by C. Roos. This scheme could be a powerful technique to limit the data rate to a reasonable level. It does demand a slightly more elaborate electronics system in the string module, potentially increasing the vulnerability of the system to a critical failure.

Since a large fraction of the "true" muon signals generate a coincidence between adjacent modules in a given string, an alternate method to the largest amplitude signal being given priority would be to give those signals a higher priority which have a coincidence in the nearest neighbor module on the string. To accomplish this, on the arrival of a detector signal at the digitizing electronics in each string processing module, a short gate ( $\approx 100$  nsec) is generated and passed to the logic handling the two adjacent detectors. If a coincidence match is made within the gate window, then a bit is set in the event register indicating the coincidence and that event is given priority over other events independent of the relative amplitudes of the signals. The length of the gate is chosen to be large enough to accommodate the light signal transit time between detectors, yet short enough to suppress most accidental  $K^40$  coincidences.

A further refinement of this option is made by defining two different discriminator levels in the detector module, e.g., one set typically at 1 P.E. and a second at 2 P.E. Both signals would be transmitted to the string module with an associated flag so as to distinguish between them. (The flag might be a small notch inserted in the detector signal). In the string module logic, only those 1 P.E. signals which were flagged as being in coincidence with a near neighbor would be retained. The larger signals would be treated in the manner described earlier.

## BROAD BAND SIGNALS

In this section, the characteristics of the broad band communications link is described. It is assumed that the bandwidth of each of the optical fibers is such that they will handle a standard T3 ( $\approx$  44 MHz) telecommunications signal. It is also assumed that the necessary driving electronics is likely to be available from commercial telecommunications sources. If for any reason this total bandwidth is not available, then it becomes mandatory to implement some of the more complex logic schemes to suppress much of the data generated by each detector at the array or increase the standard sampling time with resulting lost data and more timing bits in the data word. We assume here, however, that this level of cable will be available and will be utilized.

Each detector string feeds a single fiber optics transmission line with its sequence of data words. The signal stream is time-multiplexed so that each detector on the string is allocated a well-defined position in the transmission sequence. Furthermore, each time slot is of fixed length; in the current example, 24 bits are sent for each detector. With a total of 24 detectors, including the ancillary detectors, this represents a sequence of 24 x 24 or 576 bits transmitted for each full cycle. With a transmission frequency of 44 MHz, a new data transmission cycle occurs once every  $\approx$  13 microseconds. The transmission multiplexer serializes the data in each event buffer for each detector in turn and inserts the data onto the transmission signal at the appropriate time. Null signals (i.e., for those detectors which have not recorded even a noise pulse in the previous time window and, therefore, have no data to report) are transmitted as a coded null signal so as not to send a sequence of 24 zeroes. Of course, if, as the details of the system are developed, it appears that a larger data word must be allocated for each detector, e.g., if additional information for the shape of the signal is to be included, then the length of each time slot must be appropriately increased and the time period for each full transmission cycle must accordingly increase.

This cyclical transmission of data continues as long as the system is in data mode. Each new cycle is preceded by a unique coded header block differing from any possible data set which indicates to the shore receivers that this is the initialization of a new data cycle. A trailing block containing a transmission cyclical checksum word and possibly additional information terminates the cycle. (There are a number of 24-bit coded sequences, which should not be valid sequences for proper data sets, available for the required block codes). With such a scheme using unique header blocks, it is possible also to define other modes for transmission of special classes of data from the detector to the shore and label it as such. Thus, for example, if the string detector periodically enters a number of different calibration modes, different header blocks can be chosen to

delineate each of these separate classes of data. In all cases, the header will uniquely define the class of data in that transmission.

It is also assumed that the primary cable between detector and shore can be bi-directional. The details of whether this happens or not is related to what the precise technology will be available at the time design commitments must be made. Certainly, there are available half-duplex and full-duplex modes well developed for transmission via fiber optics techniques at this time<sup>(11)</sup>. Thus, it should be possible to communicate from shore to each string processor via the fiber optics cable to initiate modes of operation and/or to transmit program data, or to reorganize control memory and other logical circuit parameters.

One of the optics fiber lines in each cable bundle between the array and the shore station is dedicated to the clock signal. Thus, there is one master clock on shore operating at  $\sim 100$  MHz which is fanned out to each of six fiber optics cables going to each of the planes of the array. About once every 40 microseconds (three 13  $\mu$ sec sampling times) a coded signal is imposed upon the clock signal, which is interpreted by the string module logic to initiate resets for the scalars counting these clock pulses in each of the string processors. The reset signal can be represented by the lack of signal pulses for a predetermined period (e.g., one or two clock pulses) or by a change in the pulse amplitude. Thus, once the system is functioning as set up by control signals through the control signal lines, every time the clock sequence goes barren for the synchronizing pulses, the string processors reset their clock scalars. Clock scalars themselves need not lose the time during these four clock cycles because they contain slave clocks of approximately the right frequency which will maintain the time adequately well during the barren cycles.<sup>(17)</sup>

With this approach the time is kept modulo the clock reset cycle time. The clock wrap around is a minor complication which must be taken into account by the shore processor for the off-line analysis. The choice of the reset period is related to the full transmission cycle time. The reset period should be several times (e.g., 3 times) that period to ensure that there is no ambiguity in the time due to the wrap-around. A 40 microsecond period requires a 12 bit clock scaler.

The transmission cable from the plane module to shore will also bring the necessary DC power to the array plane using standard underwater power transmission techniques, if the power consumption allows. The details of whether the return is carried by ocean water or by another conductor in the cable are problems yet to be solved and are addressed<sup>(10)</sup> elsewhere in these Proceedings.

As indicated above, the transmission of signals for controlling the system may be accomplished by using the fiber optics communications lines bi-directionally. If for some reason the bi-directional use of these transmission lines turns out to be too expensive or too complex to implement, a much lower bandwidth communication system may be established using the power conductor system and standard modem communications techniques. Only relatively low bandwidth is required here, i.e., 9.6 Kbaud. Thus, overall control of the whole system can be accomplished by utilizing such a slow but robust communication system. If for any reason the power distribution must be used for this function, such an approach would handle the whole workload, albeit with longer periods for some of the more complex operations, such as downloading of memory elements.

### CONTROL COMMUNICATIONS

To ensure that the detector array functions reliably and consistently over some period of time, great care must be taken to allow for adequate control and monitoring of the status of the parameters of each of the array elements. Thus, it is crucial that it be possible to monitor the state of important elements and also to be able to change the status of or turn on and off all elements of the detector array. On the other hand, one must be careful here not to increase the complexity of the system unduly, thereby overburdening some or all of the elements of the detector for the sake of flexibility and extensive monitoring.

The proposed procedure for accomplishing this end is to use a small CMOS microprocessor, (e.g., an 8-bit device such as the 8080 or equivalent), in each active element of the array. Such an approach probably gives rise to the least expensive implementation of the control and monitoring functions and also increases the flexibility to accommodate to changes during the design and testing period. It will also allow for changes to correct faults in design, or to change goals once the instrument is deployed.

The communications between the shore and the string module would be handled by either hardwired circuits or by a microprocessor driven by a carefully debugged program residing in a ROM memory. Thus, the basic communications protocol would be part of the basic operating system and would have to be left unchanged for the life of the experiment. Data which flows from shore to such a receiver, probably in packet form, would be buffered and then distributed appropriately to all of the modules in each string. That communication would occur multiplexed onto the local string power line. Furthermore, each packet would contain a header containing the module ID number of the addressed module. Each individual potential receiver would decode all such communications and either accept or disregard the message. Some messages could be of the broadcast variety which are addressed to

all or a collection of modules of the array. Thus, at initialization time, one can initialize all processors in the system by issuing a reset and then downloading a sequence which loads all memories and all processors for basic functions. Special functions required by individual modules are then additionally loaded by addressing those explicitly.

There are very few parameters that normally would have to be changed in the detector units. These include the PMT high voltages and the discriminator levels for defining the threshold for useful data. Although in principle these values could be found by the detector itself based upon a calibration procedure invoked periodically, it would be unwise to let the detector automatically find and set these without some involvement of higher order elements including a human operator in the loop. The setting of these values would be one of the important functions of the array control system. Other functions would be to control the state of the detectors and to command them to change from a data-taking state to a calibration state. There may be a number of different types of calibrations including high voltage plateaus, discriminator thresholds and timing measurements which are implemented.

Additional functions of the control system would be to maintain a short-term history of the status of important parameters. These include monitoring the temperature, humidity, the read back values of the high voltage and of the discriminator setting and other measurements of the detector performance such as an average singles rate and/or an equivalent integrated current. These values would normally be periodically transmitted to the shore station as a status block. Unusual situations might cause a special interrupt alarm to be sent to the shore station reporting the problem. This may initiate remedial action to prevent damage. Another function that would be controlled would be the logical removal of a detector from the system because of a diagnosed malfunction. This could be done either at the detector itself if it was capable of doing so, or if that failed, at the string module where the information coming from an errant detector can be disregarded. Other important control functions include the switching between primary and backup circuitry especially in the string and plane modules if that were necessary. To the largest extent possible, fault detection and component switching should be done automatically in a fail-safe manner. Nevertheless, it is likely that some level of control should be exercised on command from the shore station.

The string modules would have additional important functions to monitor. These include communications error rates as detected by parity checks, aberrant signals including signals which exceed maximum times or amplitudes and singles rates which are unduly high.

## CALIBRATIONS

There are a number of calibrations which must be built into the array to reliably maintain the system. The transfer from data-taking mode to calibration modes will be under control of the shore processors communicating with all the elements of the array via a broadcast mode.

One important calibration procedure would be the detector PMT high voltage plateau curve to define the right operating high voltage point for the PMT's. For setting the operating level for the discriminator, the  $K^{40}$  singles rate which is so readily available to this detector system, could be used. All calibration data would be treated just as if it were event data and transmitted to shore with appropriate header blocks indicating the calibration nature of the data. The final decision for operating points for each detector would be made on shore with the intervention of the operators if there were obviously aberrant values.

One of the most difficult problems to be solved is the precise understanding of the equivalent time position for each detector signal. In principle, the length of all cables and the delays of all circuit elements can be measured before the detector array is deployed. Of course, this should be done, but nevertheless it will be crucial to be able to check the actual situation once the array is deployed. This would take into account unplanned physical placement variations, motion in the ocean currents, temperature effects and the gremlins which effect all systems. Furthermore, an in situ measurement of this type is an ideal way to monitor the overall system to ensure that some component(s) are not degrading or that the detector is not beginning to wander from its moorings.

One method for making the timing/position measurement is to place a medium or small power xenon nanosecond flash lamp in each detector sphere. A procedure can then be invoked whereby the lamps are sequentially fired in all of the detectors in a prescribed manner. The details must be thought through very carefully, but essentially the procedure would be as follows. In detector IJK, turn off the local high voltage (so as not to destroy the PMT) generate a trigger pulse to flash the lamp and transmit as data the trigger pulse from that detector. The leading edge of that pulse defines the time at which the lamp is flashed. Delay times for the actual light relative to the trigger pulse can be reasonably well known and appropriate corrections can be applied. The light from this flash should be seen by a number of other detectors in the array including those in the region represented by  $I \pm 1$ ,  $J \pm 1$ ,  $K \pm 1$ . These detectors will transmit their received signals in the usual manner down each of their optical fiber lines and would be timed by their leading edge as with the data. This information would be received on shore with

appropriate identifiers indicating that this is calibration data. The procedure continues through each element IJK giving a net of data with much overdetermination, thus allowing for the unscrambling of the times of transit in cables as well as through the water.

#### POWER NEEDS AND COST ESTIMATES

Without a detailed design of the detector and electronics, the cost and power needs of the array are difficult to estimate. With some crude conceptual designs, it is estimated that the cost of electronics, including, PMT's, power supplies, processors and communications transmitters and receivers would cost about \$3K/detector. Thus, the total cost of the electronics would be in excess of \$2M. This does not include the cost of the Benthos-sphere, the fiber optics cable, the on-shore processor and other miscellaneous hardware. The associated power needs should be less than 3KW per plane.

#### CONCLUSIONS

Based upon the current 1981 Standard DUMAND Detector Array and advances in under water fiber optics cable technology and fiber optics communications technology in general, a data acquisition and communications scheme has been developed. It appears feasible to take the point of view that all significant data accumulated on the ocean floor can be gathered and transmitted to shore from all detectors. The bandwidth required is high, but not so high that a multiplicity of fiber optics cables cannot accomplish the chore. The concept developed here assigns each string of 21 primary detectors and up to 3 ancillary detectors on each string to a single fiber optics cable which transmits its data at Bell System T3 (44MHz) rates. This gives rise to a sampling period of just about 13 microseconds for all the elements in the string which is well matched to the expected single rates. With double buffering and a procedure which replaces lower priority signals with higher priority signals if they appear in one data sampling time period, the transmission system should keep pace with the data rate. To further optimize the data selection for transmission at the fixed rate, an optional limited coincidence with nearest neighbor scheme is possible.

The system should be capable of entering various checking and calibration modes and also to accumulate a large amount of singles rate information. This makes available enough information to calibrate and monitor the functioning of the array. These functions, as well as certain other status and control functions, can all be controlled by small inexpensive 8-bit microprocessors residing in each detector, string and plane module.

For transmission of the data to the shore, the fibers are bundled together in groups of seven, equivalent to the number of strings in a deployed sub-unit (i.e., a plane in the example given) and one clock line, and are incorporated into one array plane to shore cable. There is one such cable connecting each of the sub-units to shore. Additional fibers may be appropriate in each cable for redundancy purposes. Using techniques developed for undersea cables, the power for the array can be carried in the sheathing of the one relatively modest size fiber optics cable. Each of the six planes will be separately powered and connected to shore for two-way communications.

Mechanisms for coding and digitizing the analog signals, and also coherently measuring the time are consistent with the transmission rates. No clock signals are required at the detector elements. All precision clocking for one string is accomplished with one clock signal in the string processor. The only problem that remains is to guarantee that each of the strings have coherent clock signals. Inexpensive techniques are available to solve that problem. Control and status procedures have been developed including mechanisms for entering a calibration mode, downloading and monitoring the systems.



REFERENCES

1. C. Akerlof, R. H. March, G. A. Snow, and D. Theriot, Proceedings of the 1978 DUMAND Workshop, p. 165 (Hawaii DUMAND Center) 1978.
2. S. J. Cowen, G. D. Gilbert and J. T. Redfern, ibid, p. 97.
3. A. E. Brenner, D. Theriot and R. H. March, Proceedings of the 1980 DUMAND Signal Processing Workshop, p. 131 (Hawaii DUMAND Center) 1980.
4. George A. Wilkins, ibid, p. 160.
5. Carl Akerlof, ibid, p. 119.
6. V. Stenger - (1981 Standard Array) These Proceedings.
7. J. G. Learned, Proceedings of the 1980 DUMAND International Symposium, I, 242 (Hawaii DUMAND Center) 1981.
8. J. G. Learned, A Proposed Deployment and Signal Processing Scheme - These Proceedings.
9. A. Roberts, A proposed new deployment scheme: The DUMAND Tower, DUMAND Note HDC 81-1.
10. George A. Wilkins - These Proceedings.
11. George A. Wilkins, Proceedings of the International Telemetry Conference, San Diego, California, p. 267 (1980); G. Wilkins, A. Nakagawa, N. Kamikawa, D. Baldwin and P. Couch, ibid, p. 245.
12. Arthur Roberts - ("Smart" detector) These Proceedings.
13. Model 2040-17, Benthos, Inc., North Falmouth, MA 02556.
14. The details of the scenario given here are not important. Any number of other approaches will satisfy the buffering needs. For a slightly different approach, explained in greater detail, see the paper Ocean Electronics for DUMAND, B. D. Geelhood, These Proceedings.
15. Flash encoders or more properly flash analog to digital converters are manufactured by TRW, RCA and Ferranti.
16. Charles Roos - These Proceedings.
17. An alternate clock scheme would transmit precision time pulses from the master shore clock, i.e., once  $\sim 40 \mu\text{sec}$ , for reset and synchronization purposes. Local crystal clocks would maintain the time at each string processor within each cycle.

## FIGURE CAPTIONS

1. The conceptual topological arrangement of a single plane of the Dumand array. Here each D represents a detector, each in its own Benthos sphere. The thin lines represent optical fiber data lines and the thicker elements represent power and control communications lines. All are connected eventually into the plane processor module. Each string requires one fiber optics line to shore for data communications. In addition, a single fiber optics line carries the master clock signals to the plane processor from shore. The sheath of the bundled cable with seven or more optical lines carries the power for the array plane. The return may be via sea water or another conducting line. Other arrangements are possible and that illustrated here is given as a working example. It should also be noted that the current array deploys only 21 detectors on the string relevant to the primary DUMAND experiment. The three additional detectors on each string are general-purpose detectors for other undersea experiments not related to the primary experiment.
2. A possible "dumb" PMT detector arrangement. Each detector is housed in a standard underwater Benthos sphere. Note that the power feedthrough breaks through the sphere whereas the fiber optics feedthrough is a non-penetrating optical connection through the sphere.
3. An overall block diagram of the logic inside each detector module. If a "smart" PMT is used instead, or if multiple samples of each pulse are taken, the logic becomes slightly more complex.
4. An overall block diagram of the logic in the string or plane processor module. The diagram shows an implementation of the near neighbor or limited coincidence option.

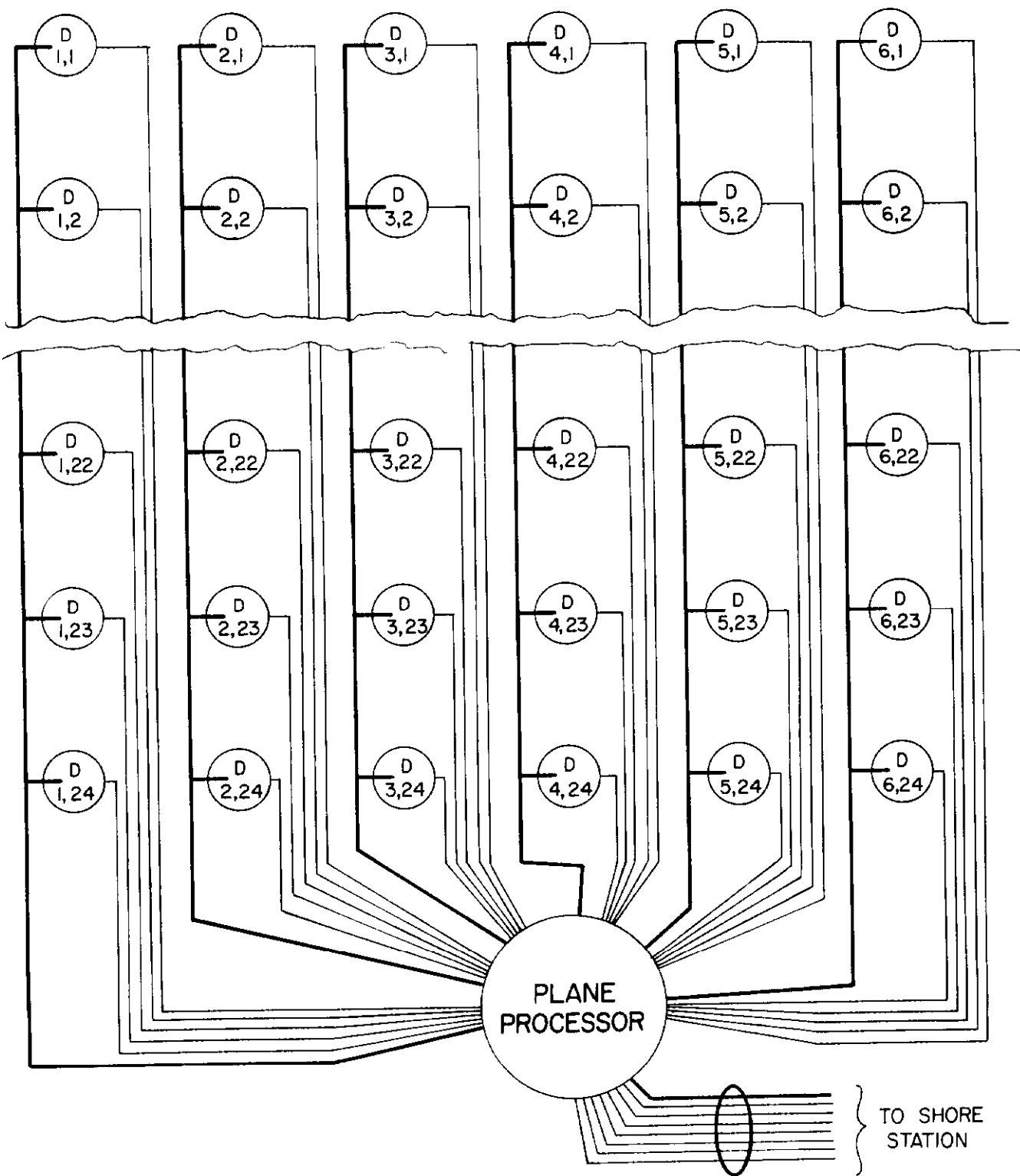

Fig. 1

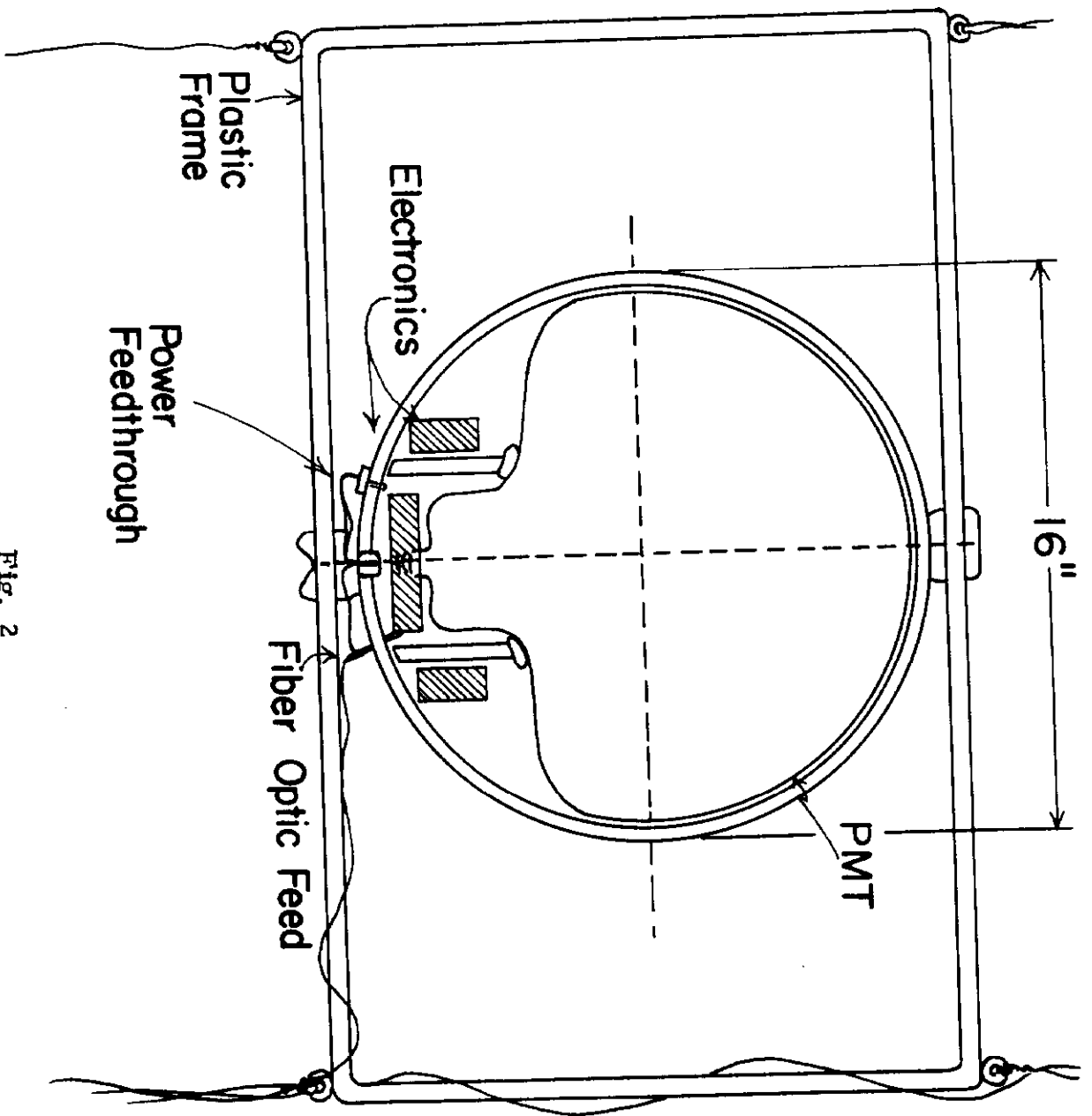

Fig. 2

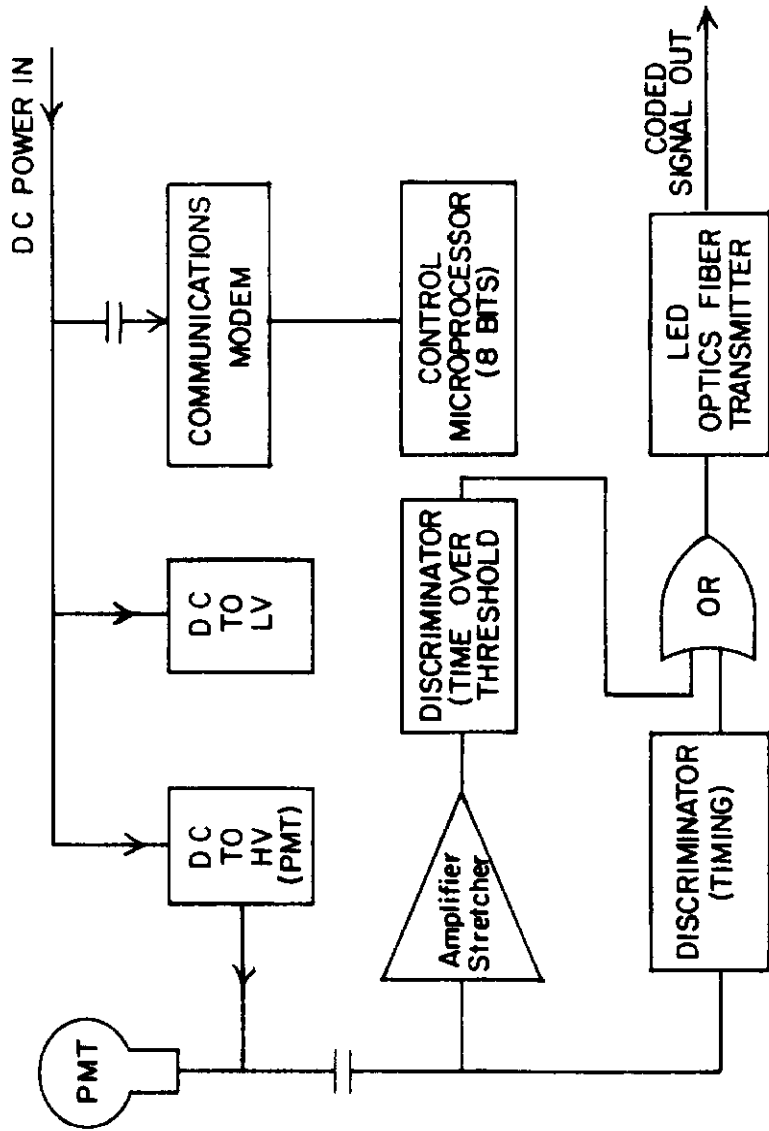

Fig. 3

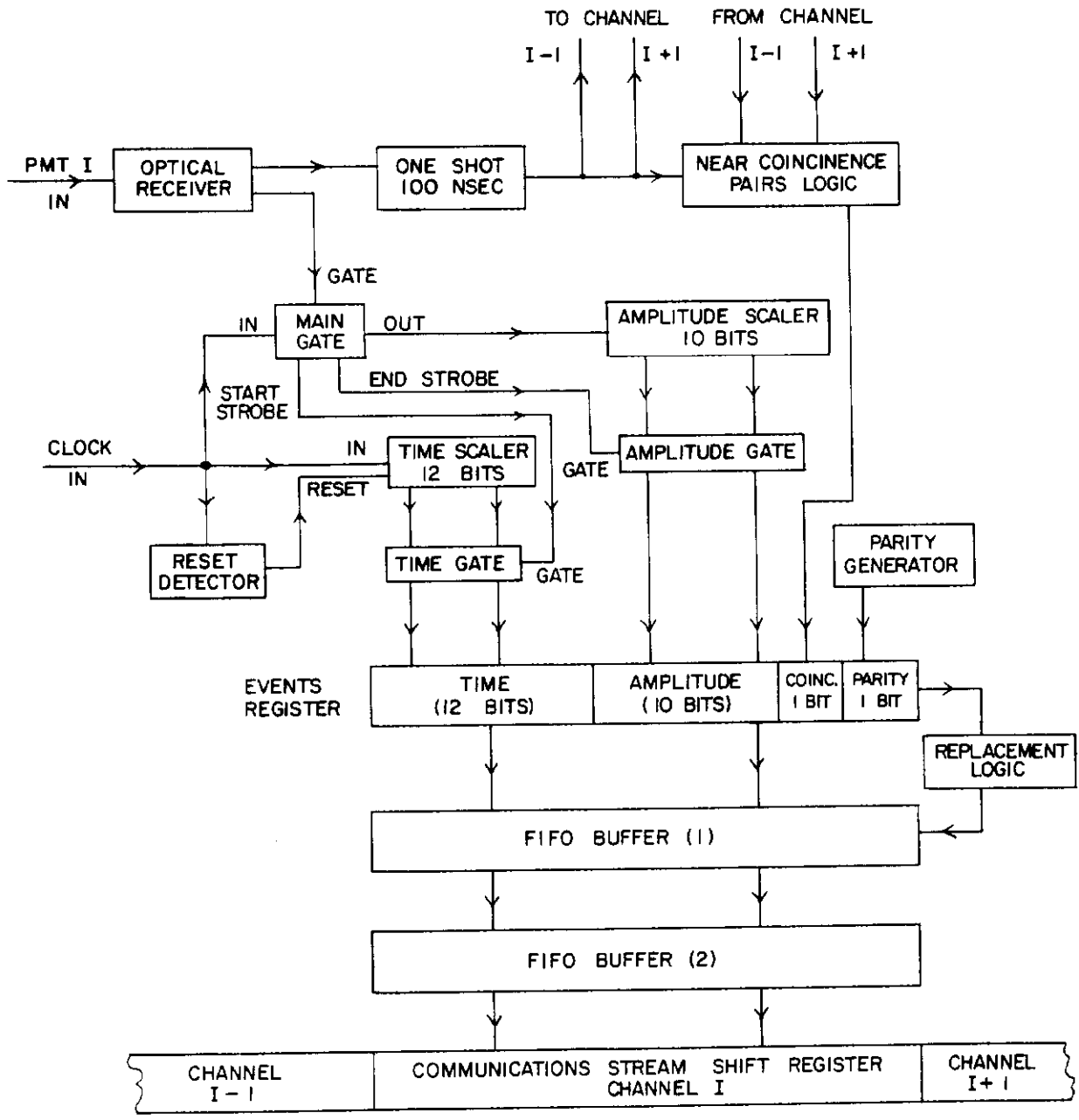

Fig. 4