

CRYOGENIC SYSTEM FOR PRODUCTION TESTING AND MEASUREMENT OF FERMILAB ENERGY SAVER SUPERCONDUCTING MAGNETS
 W.E. Cooper, A.J. Bianchi, R.K. Barger, F.B. Johnson, K.J. McGuire, K.D. Pinyan, F.R. Wilson
 Fermi National Accelerator Laboratory, Batavia, Illinois 60510

Summary

The cryogenic system of the Fermilab Magnet Test Facility has been used to provide cooling for the testing of approximately 1200 Energy Saver superconducting magnets. The system provides liquid helium, liquid nitrogen, gas purification, and vacuum support for six magnet test stands. It provides for simultaneous high current testing of two superconducting magnets and non-high current cold testing of two additional magnets. The cryogenic system has been in operation for about 32000 hours. The 1200 magnets have taken slightly more than three years to test.

System Layout

The major components of the cryogenic system are shown in Figure 1. Liquid helium for cooling the magnets is supplied by a CTi/Sulzer 1500 Watt refrigerator. Liquid nitrogen is obtained directly from trailers. The helium compressors which supply the refrigerator also provide high pressure helium gas for purging magnets before cooldown and for warming them after measurement. Nitrogen warm-up gas is obtained from the LN2 trailer boil-off. For convenience in mounting measurement instrumentation, the test stands are staggered on either side of an overhead cryogen/gas distribution system.

Figure 1 Major components of Cryogenic System

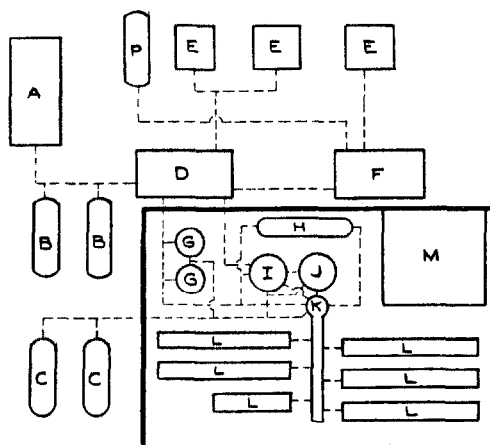

LEGEND:

- A. HELIUM GAS STORAGE
- B. HELIUM TUBE TRAILERS
- C. LIQUID NITROGEN TRAILERS
- D. HELIUM COMPRESSOR BUILDING AND WATER PUMPS
- E. COOLING TOWERS
- F. AIR COMPRESSOR BUILDING AND WATER PUMPS
- G. HELIUM PURIFIERS
- H. HELIUM QUENCH TANKS
- I. HELIUM REFRIGERATOR COLD BOX
- J. LIQUID HELIUM DEWAR
- K. SUB-COOLERS AND DISTRIBUTION BOX
- L. TEST STANDS
- M. CONTROL ROOM
- P. BACK-UP AIR

Helium System

Liquid helium is provided to the magnets with a closed cycle refrigerator system. The refrigerator is a joint CTi/Sulzer design; it employs two Sulzer TGL-22 gas bearing turbines with magnetic thrust pre-load. Table 1 gives typical operating parameters for the turbines. Helium is liquified through a J-T valve after the second turbine to avoid possibly destructive cavitation in the turbine. The liquid helium inventory is stored in a 10000 liter dewar. In order to provide forced flow through the magnets, the dewar pressure is maintained at 1.8 to 1.9 atm. and the return flow from the magnets is routed through the refrigerator to a point controlled at 1.05 atm.

Table 1. Typical Turbine Operating Parameters

Turbine	T1	T2
Inlet pressure (Atm)	8 to 14	10 to 14.5
Expansion ratio	3.1 to 5.4	3.3 to 4.7
Flow (g/s)	75 to 90	75 to 90
Inlet temperature (K)	16 to 22	7 to 9
Speed (rps)	2900 to 3400	1800 to 2700

Helium flow for the refrigerator is provided by two Sullair C25L oil injected screw compressors. A multi-stage oil removal system recovers oil from the helium before the helium passes to the refrigerator. Helium gas is stored in a 4000 cubic foot buffer tank at pressures ranging from 4 to 12 atmospheres. Make-up helium is supplied from tube trailers. The maximum high pressure flow of the compressor system is about 210 g/s; the maximum low pressure flow is about 100 g/s. This maximum low pressure flow limits total flow to the test stands to below 100 g/s. Compressor discharge pressure is regulated between 10 and 15 atmospheres as one means of controlling total refrigeration. Figure 2 gives diagrams of the compressor and refrigerator systems.

Figure 2a Helium Compressor

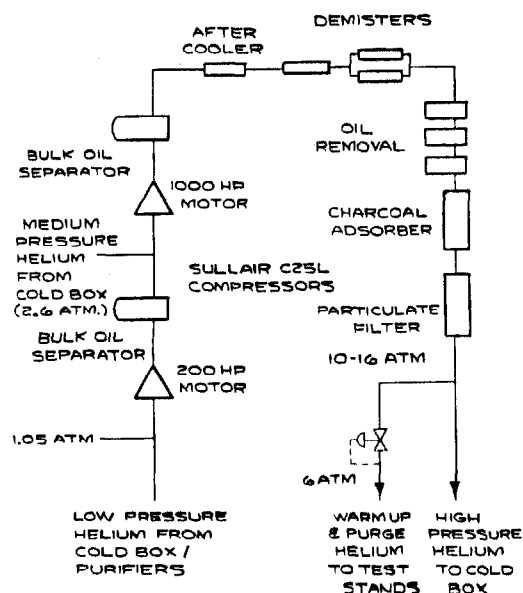

* Operated by University Research Association, Inc. under contract with the U.S. Department of Energy

Figure 2b Helium Refrigerator

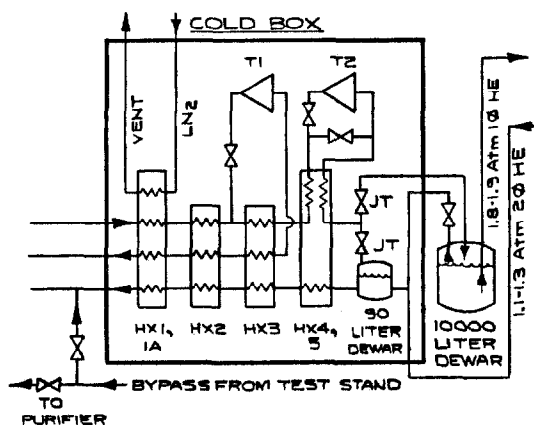
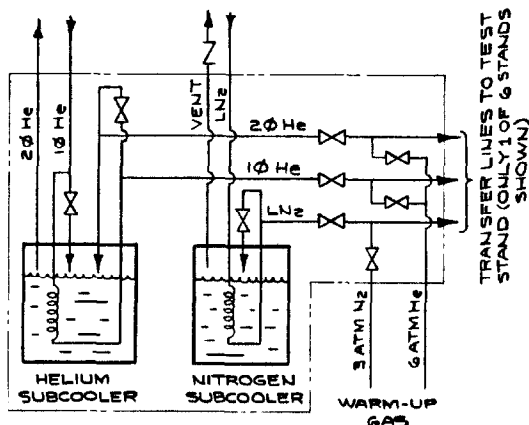

Figure 3 Distribution Box



A Diagram of the stand flow system is given in Figure 4.

Figure 4

Helium gas is purified with two activated charcoal adsorbers operated at LN₂ temperature. These purifiers have manifolding so that they can be used to clean system gas, tube trailer gas, buffer tank gas, quench tank gas, or return gas from magnets being purged. They can also be used to provide high purity helium for decontamination of various portions of the system. The use of two purifiers allows one to be used while the other is being decontaminated.

Two 1000 gallon tanks are used for temporary storage of helium gas recovered from quenching magnets and serve the important function of minimizing system disruption from the quenching of magnets. The pressure rise in these tanks during a severe quench is less than 2 atm. The tanks limit the rise in the low pressure compressor line to about 3 psi during severe quenches.

Nitrogen System

Nitrogen is supplied to the system from two liquid nitrogen trailers. Typically, one trailer is used to supply liquid and the second to supply gas from boil off although interconnections permit either trailer to supply both liquid and gas. Liquid nitrogen is supplied to the test stands, to the first refrigerator heat exchanger for pre-cooling the helium, to the dewar shield, and to the purifiers. Nitrogen gas is supplied to the test stands for warming magnets and to the purifiers to aid in warm-up for decontamination. Nitrogen and helium systems are totally separated.

Distribution System and Test Stands

Liquid helium and nitrogen are supplied to the test stands through a vacuum insulated distribution box. Connections on the distribution box permit warm helium and nitrogen gas to be supplied as well. A diagram of the box is given in Figure 3. Helium and nitrogen subcoolers lower the incoming liquid temperature and help ensure that the liquid is bubble free. Valves on the distribution box control the supply of liquid helium, liquid nitrogen, gaseous helium, and gaseous nitrogen to each test stand. The return of helium liquid/gas mixture from the test stands can also be controlled. Connections between the distribution box and test stands are made through vacuum insulated transfer lines.

TEST STAND FLOW SYSTEM

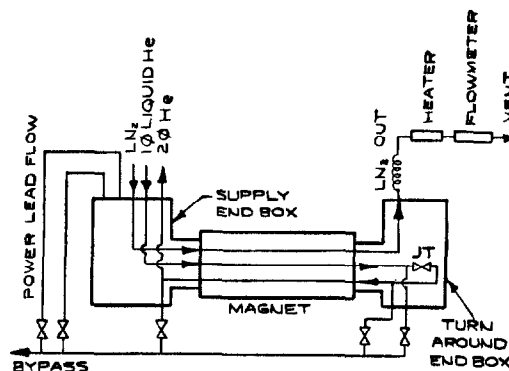

SUPPLY BOX DETAIL

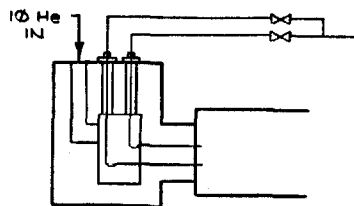

Each stand has vacuum insulated supply and turn-around boxes which interface the magnet under test with cryogenic, gas, vacuum, and electrical system. Liquid flow is from the downstream to the upstream end of the magnet, i.e., in the opposite direction from the proton beam in the ring. Liquid nitrogen passes through the magnet in only one direction and is vented after it reaches the turn-around box. Liquid helium expands through a J-T valve in the turn-around box and returns through "2φ" magnet passages as a liquid/gas mixture. Heat exchange in the magnet between this mixture and the liquid in the "1φ" magnet passages lowers the 1φ temperature.

1φ connections between the magnet and endboxes use Conoseal fittings. 2φ and LN₂ connections use C-seal fittings. The magnet insulating vacuum communicates directly with endbox vacuum. Unlike the installation in the ring, the magnet beam tube vacuum communicates with the magnet insulating vacuum on the test stand. A double-walled vacuum insulated tube is inserted through the endboxes into the magnet bore. This tube allows room temperature instrumentation to be inserted into the magnet bore while the magnet is at cryogenic temperatures. Seals between the outer wall

of this tube and the endboxes establish vacuum integrity. Stand/magnet vacuum is provided with a Sargent-Welch 3106G (400 liter/second) turbo-molecular pump backed by a Sargent-Welch 1397 roughing pump. On each stand, connections are made to each end box using 6 inch piping from the pumping station located centrally below the magnet position.

Magnet coil and bus superconducting leads are brought out of the magnet through the 1 ϕ passages. At the turn-around box, the magnet coil and bus leads are spliced directly together; no external connection is made. At the supply end box the magnet leads are spliced to superconductor leads which are part of the end box.

Modified American Magnetics L-5000 gas cooled power leads are used to connect these superconductors to external power buswork. The connections between the American Magnetic leads and the end box superconductors are made using copper transition pieces. These connections are made in an internal supply box can through which the supply liquid helium flow is directed. A small portion of the flow is brought out of the top to the internal can through the L-5000 leads to cool them. At the turn-around box, the coil-bus splice is made in the 1 ϕ piping at the interface between the magnet and endbox. A J-T valve in the turn-around box allows 1 ϕ liquid to expand and flow as a liquid/gas mixture back through the magnet 2 ϕ passages.

Bypass valving is connected to the 1 ϕ piping at the turn-around box and to the 2 ϕ piping at the turn-around and supply end boxes. This bypass valving is used to circumvent effects of the magnet 1 ϕ -2 ϕ heat exchange during magnet cooldown. The same lines can be used to evacuate the magnet helium passages for decontamination prior to cooldown.

The relief of quench gases is provided through 4 paths. At the supply box, 1 ϕ relief is provided through piloted Fermilab design "Walker valves" and parallel pneumatically operated 1 $\frac{1}{2}$ inch Whitey valves. Both of these valves are opened on the detection of a quench. The Walker valve will also open when 1 ϕ pressure exceeds 30 psig. Fermilab design "Kautzky valves" are mounted on the magnet 1 ϕ relief port. These valves are set to open at a magnet 1 ϕ pressure of 32 psig. Circle Seal 1 $\frac{1}{2}$ inch relief valves are mounted in the turn-around box 1 ϕ bypass piping. These relieve at 20 psig. Each relief valve is connected through manifolding and piping to the quench tanks for recovery of quench gas.

Instrumentation

Except for on the test stands, helium system instrumentation employs Lakeshore silicon diodes for temperature measurement, Dynisco transducers for pressure measurement, American Magnetics liquid level gauges, venturis for flow measurement, and Televac thermocouple and cold cathode gauges for vacuum measurement. Fisher controllers are used for process control. Valve control and additional pressure monitoring uses equipment from a variety of manufacturers including Fairchild, Fisher, Foxboro, Moore, Rosemount, Dwyer, Penn, and United Electric. A Texas Instrument 5TI system is used for overall process control and system interlocks. Helium purity is monitored with a "chromatograph" system developed by R. Walker.²

Magnet 1 ϕ and 2 ϕ pressure and temperatures are measured at each endbox using pressure taps and conventional pressure gauges for pressure measurement and helium vapor pressure thermometers for temperature measurement. Venturi gauges in the 1 ϕ transfer line to each stand monitor liquid flow to the stand. Stand temperatures, pressures, and flows are manually recorded with accuracies of 0.01K, 0.25 psi, and 1.0 gram/second respectively. Interlocked liquid level probes in the endbox internal lead can ensure that

the can is adequately filled during testing. Similar instrumentation is used to monitor the helium subcooler on the distribution box and the overall distribution system performance.

Electrical connections are made through the supply box internal can and the 1 ϕ passage to the magnet to the endbox/magnet splices. Additional connections to the L-5000 leads where they exit the endbox are used to protect the power lead/magnet combination.

Performance

The helium refrigerator provides alternatively 1900 Watts of refrigeration or 250 liter/hour of liquification under normal operating conditions. The flexibility of the compressor/refrigerator controls permits this capacity to be reduced by a factor of approximately 10 so that changing loads are easily accommodated.

The magnet installation time, which includes magnet positioning and levelling, making electrical and cryogenic connections, leak checking, and performing an initial decontamination of helium passages, takes about 2 hours. "Scrubbing" to further clean the magnet takes an additional 1 to 2 hours. A dipole magnet takes about 4 $\frac{1}{2}$ hours to cool to measurement temperature and 5 to 6 hours to warm for removal from the test stand. Quadrupole magnets take 2 $\frac{1}{2}$ to 3 hours to cool and 4 to 5 hours to warm. Typical parameters for a cold magnet are given in Table 2.

Table 2 Typical Magnet Cooling Parameters

	In	Out
1 ϕ pressure (psig)	8.5 to 10.0	8.5 to 10.0
1 ϕ temperature (K)	4.62 to 4.74	4.63 to 4.75
2 ϕ pressure (psig)	4.0 to 5.0	4.0 to 5.0
2 ϕ temperature (K)	4.49 to 4.55	4.49 to 4.55
Flow (g/s)	23 to 29	23 to 29
Helium lead flow per power lead (g/s)	0.30 to 0.40	
Nitrogen shield flow (g/s)		3.5 to 4.2

The careful design of cryogenic system controls has permitted the system to be staffed by only 5 refrigerator operators. The system is routinely run 24 hours/day 7 days/week. It has been operated during approximately 90% of calendar time during the past 3 years. Maintenance, repairs, and vacations have contributed roughly equally to the 10% off time. This high duty factor of the cryogenic system has been an important factor in the expeditious measurement of Energy Saver magnets.

Acknowledgements

Personnel from CTI³, Sulzer Brothers Limited, Sullair Refrigeration, CCI, and CVI were particularly helpful in contributing to the design of the system and bringing it into operation. We wish to thank the numerous Fermilab personnel who contributed to the system, especially W.B. Fowler, R. Walker, M.E. Stone, W. Zimmerman, R. Yamada and D.A. Gross.⁴

Reference

1. W.E. Cooper et al. Advances in Cryogenic Engineering, Vol. 27, (1982) p. 657.
2. R. Walker, Fermilab Report TM-742 (1977).
3. Now Koch Process Systems.
4. Presently at General Electric, Inc. Schenctady, NY.