

261F-9

**PRELIMINARY DESIGN OF  
THE BPM ELECTRONICS  
MEMORY SCANNER / DUAL BOXCAR AVERAGER  
FOR THE ADVANCED PHOTON SOURCE\***

0011

**A. J. Votaw  
Argonne National Laboratory, Argonne, IL 60439**

**ABSTRACT**

The memory scanner / dual boxcar averager are VXI modules that are part of the Advanced Photon Source (APS) beam position monitor (BPM) data acquisition system. Each pair of modules is designed to gather and process digital data from up to nine digital channels transmitting the BPM data from the storage ring (360 locations) and the synchrotron (80 locations). They store beam history in a buffer, store the latest scan of all channels, and provide boxcar averaged X and Y position data for the global orbit feedback system, provide boxcar average X and Y position data for beam diagnostics, and a buffered output of SCU data as it is scanned for the beam abort interlock system. The system's capability to support single pass, closed orbit and tune measurement functions will also be briefly described.

**INTRODUCTION**

One of the most critical issues of the third-generation synchrotron radiation source such as the Advanced Photon Source (APS) is the ability to track the stored beam position with appropriate resolution and bandwidth using a beam position monitor system. The capacitive button pickup and the BPM front end electronics have been described previously,<sup>1,2</sup> and this paper concentrates on the memory scanner / dual boxcar averager which collects and processes the digital outputs from the BPM channels. In the APS storage ring there will be 360 BPM locations and the same electronics are planned for the 80 synchrotron locations. Each memory scanner / dual boxcar averager pair is designed to gather and process the data from up to nine locations. The schematic details of the electronics and the flexibility of the process to support a variety of functions including single pass commissioning runs, dual channels of stored beam position with selectable bandwidth (one for beam diagnostics, the other for global orbit feedback), tune measurements, beam history following beam faults, and linking data to the global orbit feedback and beam abort interlock systems will be described.

\* Work supported by the U.S. Department of Energy, Office of Basic Sciences, under contract no. W-31-109-ENG-38.

The submitted manuscript has been authored by a contractor of the U.S. Government under contract No. W-31-109-ENG-38. Accordingly, the U.S. Government retains a nonexclusive, royalty-free license to publish or reproduce the published form of this contribution, or allow others to do so, for U.S. Government purposes.

**MASTER**

## Background and Design Aspects

Positron beam position determination for both the storage ring and synchrotron ring of the Advanced Photon Source is performed by the Beam Position Monitor (BPM) electronics system. The system starts with capacitive button pickups mounted physically on the ring vacuum chambers. There are 360 monitoring points in the storage ring and 80 in the synchrotron. Each point has 4 buttons. The output of the 4 buttons (see figure 1) is connected to a filter comparator. This is a passive filter and signal combiner. Its output proceeds to the monopulse receiver onboard the Signal Conditioning and Digitizing Unit (SCDU). The SCDU conditions the incoming signals and produces a digital output of beam position and beam intensity. The storage ring has forty racks each holding nine SCDUs. The electronics platform for the modules is VXI.

The digital beam position and intensity data output of the SCDUs is collected by two separate cards in the VXI Crate. The first card is the Memory Scanner (SCDU Scanner and Data Memory). The memory scanner resides in the BPM Electronics VXI Crate with the SCDUs. It is designed to scan, gather and process data from up to nine SCDUs. It stores beam history in the beam history buffer, stores the latest scan of all the SCDUs and provides a buffered high speed digital output of SCDU data as it is scanned for the beam abort interlock system. All other data is accessible through the VXI interface.

The second card is the dual boxcar averager and it resides in the same VXI crate. It monitors the backplane, gathers the position data from the SCDUs, and performs two sets of running boxcar averages for the X and Y position data. One of the averagers is for beam diagnostics studies, the other averager is for the global orbit feedback system. The output to the global orbit feedback system is via a fiber optic link to the feedback interface in the global orbit feedback VME crate. All other data is accessible through the VXI interface.

The memory scanner and dual boxcar averager are digital circuitry with most of the logic contained in Programmable Logic Devices (PLDs). There is no microprocessor on either card. The two cards have several digital functions (see figures 2 & 3) all orchestrated as an Algorithmic State Machine (ASM). These functions are:

### Memory Scanner Functions

**1. VXI Interface.** Standard VXI Interface with 16 bit addressing and either 32, 16 or 8 bit data. (A16:D32:D16:D08(OE)).

**2. Status and Control Registers.** One register for scanner status and eight control registers.

**3. Scanner Module.** This module scans the SCDUs gathering the position and intensity data. At power up it also assigns scanning addresses to the SCDUs. During the data gathering phase, as the data is received, it becomes the input for the buffered output, latest reading, and beam history modules. Each of the above modules (except the buffered output) store the data for further processing.

**4. Buffered Data Output.** The buffered data output receives the incoming intensity and position data and outputs it via differential ECL to the interlock system. This is raw data for the beam abort interlock system. The digital output has the scanned data and data identifying which SCDU module produced the data along with identifiers telling if the data is intensity or position.

**5. Beam History Memory / Turns Counter.** The beam history process provides over thirty-two thousand orbit snapshots of beam history. Both the position and intensity data are stored. The beam history module combines incoming data with the count from the 17 bit turns counter (time stamp), and stores the result. This process has two modes: fill once, and continuous fill, controlled by the beam history mode control register. Each SCDU has 64K of defined storage space, allowing 32,768 scannings per SCDU to be stored for beam diagnostics. The storage space (FIFO) is accessible via the VXI interface. These features can be used to support next turn measurement studies and beam abort analysis.

#### **Dual Boxcar Averager Functions**

**1. VXI Interface.** Standard VXI Interface with 16 bit addressing and either 32, 16 or 8 bit data. (A16:D32:D16:D08(OE)).

**2. Status and Control Registers.** One register for scanner status and eight control registers.

**3. Backplane Monitor.** The backplane monitor listens to the VXI crate backplane, identifies and gathers the position data from each SCDU as it is scanned by the memory scanner. This becomes the input to the dual boxcar averagers.

**4. Dual Boxcar Averagers.** The boxcar averagers process only beam position data. The boxcar average is a sliding average and as the latest reading is added the oldest reading is subtracted. There are twelve average weights that can be selected for the number of data points averaged between the latest and the oldest data. They are 2, 4, 8, 16, 32, 64, 128, 256, 512, 1024, 2048, and 4096. As the weight of the average increases the effective bandwidth of the averaged position data decreases. The bandwidths are approximately 136 kHz, 68 kHz, 34 kHz, 17 kHz, 8.5 kHz, 4.3 kHz, 2.1 kHz, 1060 Hz, 530 Hz, 265 Hz, 133 Hz, and 66 Hz respectively for the above weights.

The two averagers each have their own control registers for setting the weights of the averages. Each averager has 9 channels with 2 data storage locations. Since the position data is either X or Y, each averager multiplexes between the X and Y storage locations. The weight of the average for each channel can be individually set to any of the above values.

### **SCANNER APPLICATIONS**

The memory scanner and dual boxcar averager, when integrated with the BPM digital modules, will support the APS operation in a number of ways.

**Single Pass.** Single pass information during commissioning is readily handled by setting triggers to collect the position data for each BPM location on a single pass.

Due to the design of the monopulse receiver electronics, the full  $\Delta X$  and  $\Delta Y$  data will actually require four single passes to construct the offset subtracted values.

**Stored Beam Condition.** Once stored beam conditions have been achieved, the memory scanner / dual boxcar averager can utilize the boxcar average feature to provide sample bandwidths from 136 kHz to 66 Hz, with the corresponding advantage of noise averaging to produce a target of 5 micron resolution at 2.1 kHz (average of 128 samples) with the standard button and storage ring vacuum chamber geometry.

**Tune Measurements.** Both rings will have a tune measurement system based on a beam kicker or pinger. The tracking of the subsequent beam positions will be done with the data acquired and processed by the memory scanner / dual boxcar averager.

**Beam History.** This feature supports the saving of the previous 32,000 turns of information following a loss of stored beam condition. This archive will allow the accelerator physicist to sort through the data to help diagnose the location and source of the fault.

**Orbit Feedback Link.** The memory scanner / dual boxcar averager also provides the raw digital position data link for the global orbit feedback system<sup>3</sup> being developed for the APS. Additionally, many features of the averager will be duplicated for independent bandwidth control in the feedback system.

## Conclusions

Design of the memory scanner / dual boxcar averager is ongoing and preliminary tests should begin in January of 1993. We have taken delivery of two VXI crates of the type we intend to use in the synchrotron and storage rings. We tested the VXI crate backplane to see if it would perform at the required speed and measured the impedance of the VXI local bus. Preliminary results are encouraging. The backplane impedance is close to 50 ohms and we have ran it as fast as 23 MHz without any data dropout. This is 10 MHz faster than the designed data rate, therefore the data transfer between the memory scanner / dual boxcar averager and the SCDUs should do quite well.

The memory scanner / dual boxcar averager's flexibility is projected to support several key functions for the BPM system at APS from commissioning to operation.

## References

1. Y. Chung and G. Decker, "Offset Calibration of the Beam Position Monitor Using External Means", AIP Conference Proceedings No. 252, pg. 217, 1992
2. E. Kahana, "Design of Beam Position Monitor Electronics for the APS Diagnostics", AIP Conference Proceedings No. 252, pg. 235, 1992

3. Y. Chung, L. Emery, and J. Kirchman, "Digital Signal Processing for Beam Position Feedback," LS Note 202, ANL, 1992

### **DISCLAIMER**

*This report was prepared as an account of work sponsored by an agency of the United States Government. Neither the United States Government nor any agency thereof, nor any of their employees, makes any warranty, express or implied, or assumes any legal liability or responsibility for the accuracy, completeness, or usefulness of any information, apparatus, product, or process disclosed, or represents that its use would not infringe privately owned rights. Reference herein to any specific commercial product, process, or service by trade name, trademark, manufacturer, or otherwise does not necessarily constitute or imply its endorsement, recommendation, or favoring by the United States Government or any agency thereof. The views and opinions of authors expressed herein do not necessarily state or reflect those of the United States Government or any agency thereof.*

# Storage Ring Beam Position Monitor Electronics System

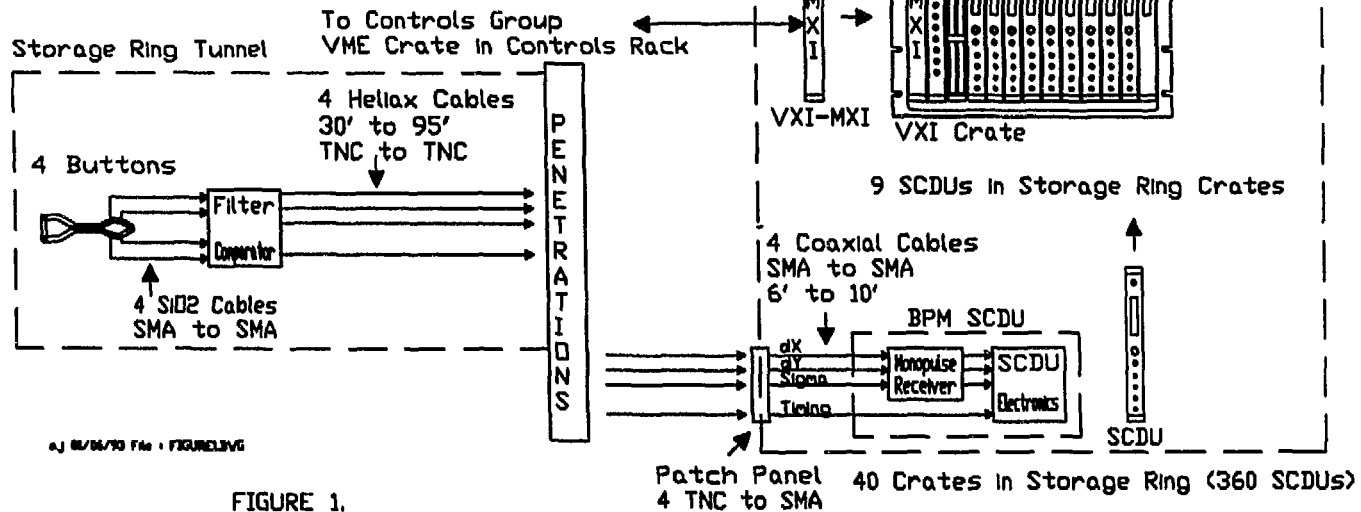

4J 82/86/70 File - FIGURE.DWG

FIGURE 1.

# SCDU Scanner and Data Memory

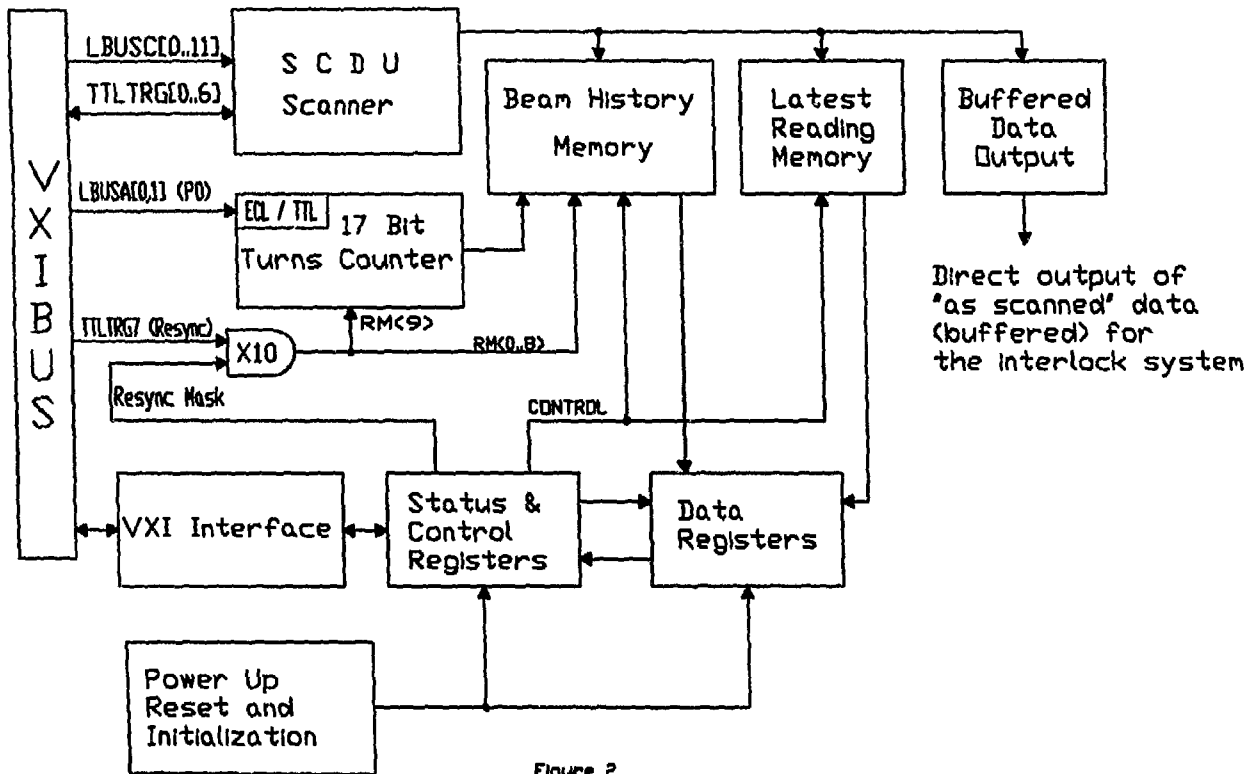
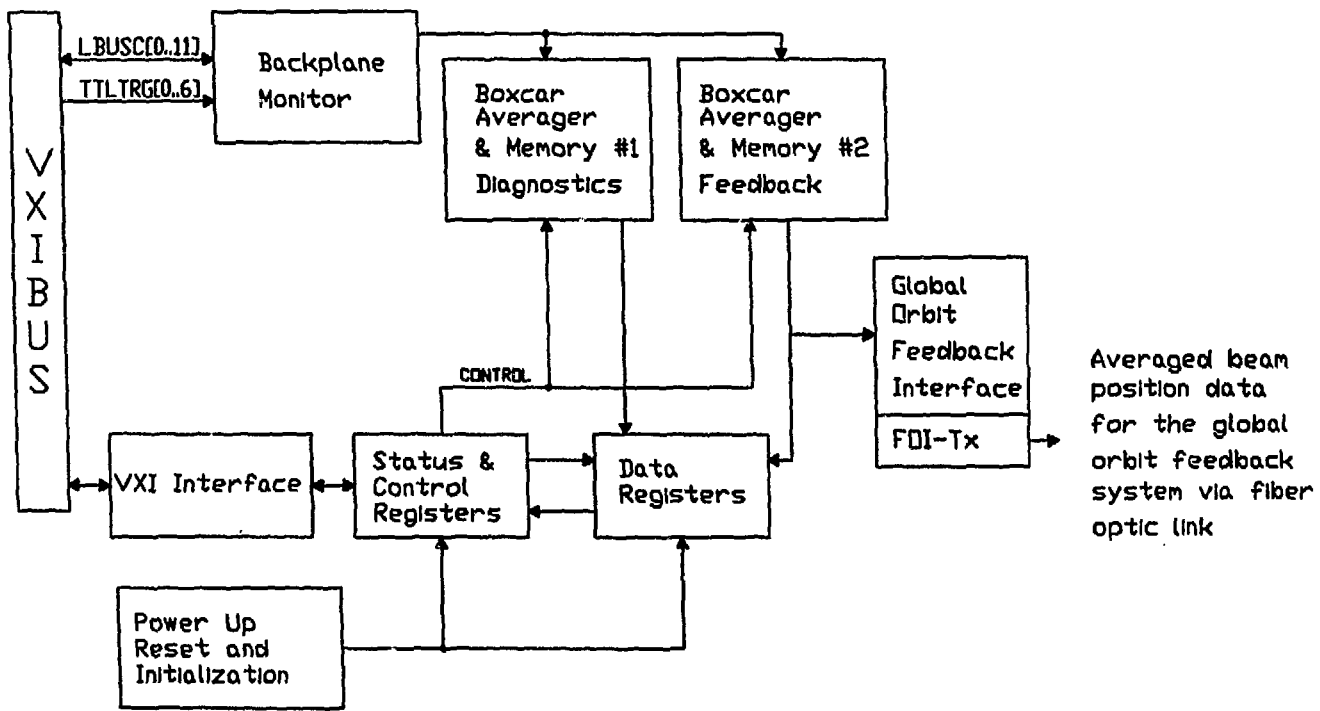

Figure 2

# Dual Boxcar Averager



4/ 20/90 File - FIBERLINK

Figure 3