

# Device Controllers using an Industrial Personal Computer of the PF 2.5-GeV Electron Linac at KEK

Yuji Otake, Mitsuhiro Yokota, Kazuhisa Kakihara,  
Yujiro Ogawa, Satoshi Ohsawa, Tetsuo Shidara and Kazuo Nakahara

National Laboratory for High Energy Physics  
1-1, Oho, Tokuba-shi, Ibaraki-ken, 305, Japan

## Abstract

Device controllers for electron guns and slits using an industrial personal computer have been designed and installed in the Photon Factory 2.5-GeV Electron Linac at KEK. The design concept of the controllers is to realize a reliable system and good productivity of hardware and software by using an industrial personal computer and a programmable sequence controller. The device controllers have been working reliably for several years.

## I. Introduction

Operators of the Photon Factory 2.5-GeV Electron Linac (PF Linac) were required to reduce the beam tuning time for starting up; therefore, detailed information concerning the accelerator was necessary in order to understand the behavior of the linac. New device control systems, including slit controllers of the beam energy analyzing system and electron gun controllers for the PF Linac, have been installed for improving the operational performance, such as monitoring the electron gun and beam parameters, since 1989.

If we consider the configuration of a device controller for an accelerator, combining a personal computer and a programmable sequence controller (sequencer) is the best solution. This is because they have the advantage of low-cost

and good productivity for a device controller. Furthermore, they are now very popular and reliable, and have many cheap circuit boards and extension units as a digital/analog I/O. A personal computer complements some of the functions of a sequencer, such as the display of data and the management of data/program file. For this reason, industrial personal computers (NEC FC-9801V) and sequencers (OMRON C200H) were employed for the device controllers. The FC-9801V has been improved in reliability, compared with the usual personal computer, like the PC-9801, and can run on BASIC encouraging non-expert programmers. On the other hand, the sequencer has also been improved regarding its immunity to bad environmental conditions.

For connecting the device controllers to the PF Linac control system, a communication board with a CPU was developed so as to be used in the industrial personal computer. The board separates communication tasks from the main CPU (CPU of the industrial personal computer), and effectively increases the system reliability.

In this paper, we describe the electron gun and slit controller systems according to the above-mentioned idea, and give a brief description of the PF Linac control system, since these device controllers act as a front-end of this control system.

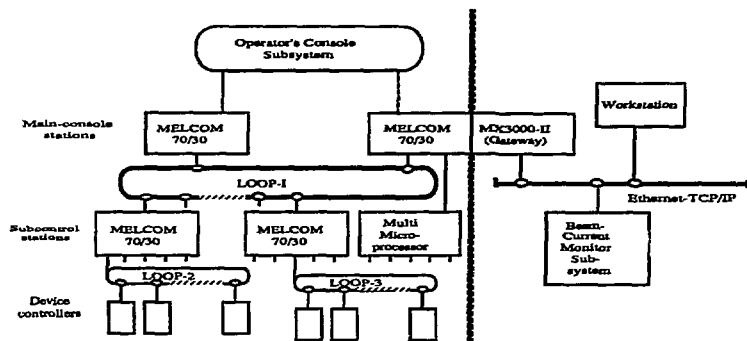

Fig. 1 Block Diagram of the PF Linac Control System

## II. Control System of the PF Linac<sup>2)</sup>

The control system of the PF Linac shown in Fig. 1 has three kinds of computer communication loops: Loop-1, Loop-2 and Loop-3. Loop-1 is an optical communication link used for the main minicomputers (Mitsubishi, MELCOM 70/30); Loop-2 and Loop-3 are optical communication links between satellite MELCOM 70/30 and the microprocessor-based device controllers.

The device controllers reported here are connected to the minicomputer system through Loop-3: asynchronous communication at a signalling rate of 50 kbit/s is possible.

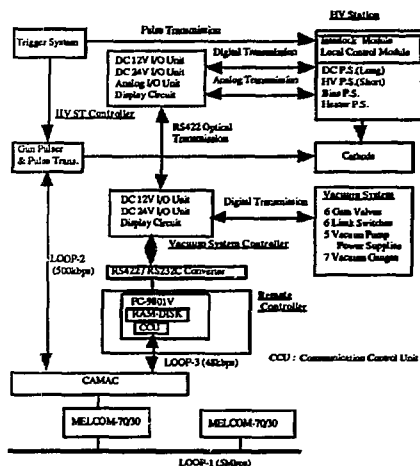

Fig. 2 Block Diagram of the Electron Gun Control System

## III. Electron Gun Control System<sup>3),4)</sup>

The device controller for the electron gun is basically constructed using an industrial personal computer (FC-9801V) and two sequencers (C200H), as shown in Fig. 2. The sequencers are used to control a high-voltage dome and a vacuum system for the electron gun. The controlled parameters of the sequencer for the high-voltage dome are the grid voltage of a long-pulse mode (1  $\mu$ s electron beam) and a short-pulse mode (4 ns electron beam); a grid bias voltage; a heater voltage and the heater current of the cathode as an analog voltage control device; and ON/OFF for the devices and the interlock items as a digital control device. The vacuum system controller mainly controls digital parameters, such as the open/close action of the gate valves, the ON/OFF for vacuum

pumps and interlock items. It also includes a few analog parameters, such as reading the vacuum gage. Usually, the digital parameters are indirectly controlled through a relay circuit from the sequencer.

The optical communication link (9.6 kbps) is based on the RS422 specification and connects the FC-9801V with the sequencers. The individual controllers must be coupled tightly, because one controller's information is important for the others. For example, if the vacuum of the electron gun is destroyed, the sequencer for the high-voltage dome must quickly turn-off the heater power supply of the cathode; otherwise, the cathode surface could be easily damaged by the poor vacuum. The optical link is used to isolate the circuits in the high-voltage dome (about 100 kV) from the ground level.

The FC-9801V, including the loop-3 communication board, has the following roles: One is a gateway for connecting the electron gun control system to the PF linac control system. It interchanges information between the sequencer system and the minicomputer system while converting each protocol. Another is to control the circuits in the high-voltage dome from the ground level. The control software for these functions were written in BASIC.

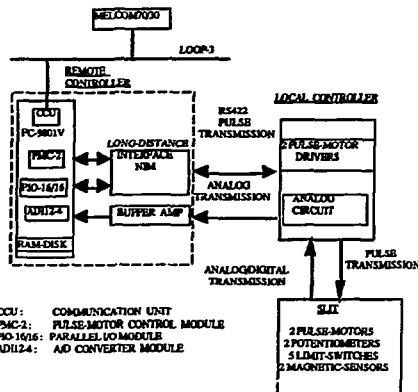

Fig. 3 Block Diagram of the Slit Control System

## IV. Beam Slit Control System<sup>5)</sup>

The beam-slit control system of the beam-energy analyzing station comprises a remote controller at the klystron gallery and local controllers at the linac tunnel. A block diagram is shown in Fig. 3. The slit controller controls two pulse motors, two potentiometers for position detection and five limit switches which detect the limitation and the

collision of moving slit blocks. The FC-9801V is used as a remote controller. One remote controller directly controls a couple of local controllers for slits utilizing an extended pulse motor control board of the FC-9801V. The pulse motor control signal generated in the remote controller is directly transferred to the local controller through the RS422 level signal interface.

The local controller includes the pulse motor drivers, which are directly connected to the slits. It also has a panel for making the slits locally controllable: control buttons for the right and left movement of slits and a position display using a digital volt meter, which shows the potentiometer voltage. The control sequence in the local mode is achieved by a logic circuit (TTL circuit) without any control software.

The control software on the remote controller was written in BASIC. The remote controller also has a control panel with a CRT display and hardware buttons controlled by the software.

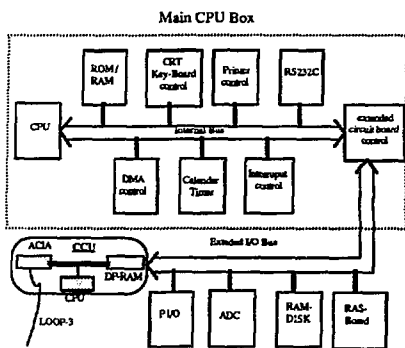

Fig. 4 Configuration of FC-9801V

## V. Components of the Device Controllers

### A. Configuration of the FC-9801V<sup>®</sup>

The FC-9801V comprises a CPU box and an expansion unit with extended circuit-boards, such as a RAM disk (1 Mbytes) with a battery back-up, a process input/output-board (PIO), an analog/digital converter-board (ADC), a Loop-3 communication-board and a RAS-board. Fig. 4 shows the system block diagram of the FC-9801V. The CPU box within the dotted line in Fig. 4 contains a CPU, a ROM/RAM-unit, a DMA control-unit, a Calendar/Timer-unit, a CRT/Keyboard control-unit, a printer control-unit, an Interrupt control-unit and an RS232C-unit.

The FC-9801V is an improved version of a conventional model of the FC-9801; it has better reliability for industrial use. It has good environmental capabilities, such

as a wide temperature allowance; an improved physical shock allowance; and improved immunity against noise from the power line. It also improves the self diagnostic functions: a watchdog timer, an over voltage check for the power supply, a temperature emergency alarm, a memory parity check, etc. The RAS-board has the above-described functions. Details concerning the improved functions are shown in Table 1.

The operating system of the FC-9801V is MS-DOS, and the software for it was written in MS-DOS-based N88-BASIC. The MS-DOS-based software system encouraged the rapid development of the control program. Furthermore, the auto-starting-up function for the FC-9801V was established by the RAM disk and by defining the AUTO-EXECUTION BATCH file of the MS-DOS system. Starting-up without a floppy disk or a hard disk has great advantages regarding reliability.

* RAS Board Function	
1, Detection of the Power Supply OFF.	-> NMI
2, Memory Parity Check.	-> NMI
3, Watchdog Timer.	-> NMI
4, Detection of the Temperature alarm.	-> NMI or INTR
5, External Alarm.	-> NMI
6, Remote Reset.	

(NMI, Non-Maskable Interrupt/ INTR, Maskable Interrupt)

Table 1 RAS Board Functions

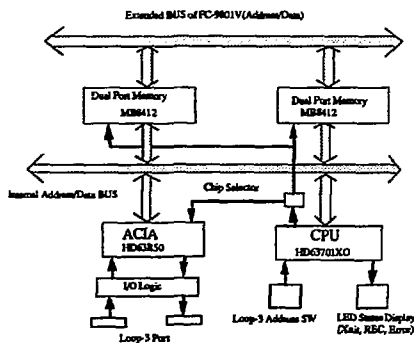

Fig. 5 Configuration of the CCU

The communication control-unit(CCU) interfaces between the device controller and the PF linac control system. Fig. 5 shows the configuration of the CCU board, which has a one-chip CPU(HD63701) with ROM and I/O ports, an asynchronous communication interface(ACIA) and dual-port RAMs. The dual-port RAMs are used to exchange control data between Loop-3 and the FC-9801V.

The BASIC program on the FC-9801V can easily handle the CCU through the mail-box on the dual-port memories. Separating of the communication task from the CPU on the FC9801V to the CCU board is extremely effective for improving the reliability and productivity of the software.

The system now works well and is reliable. By utilizing a commercially available system of an industrial personal computer and a programmable sequence controller, the electron gun and slit controllers were made. The installed battery back-up RAM disk, especially, made the maintenance easy and removed a mechanical unreliability which occurs during a program boot from a floppy disk or a hard disk; furthermore, it improves the starting-up time of the FC-9801V. Since we have adopted commercial devices and BASIC language, the device controllers could be developed.

In the future we will use a real-time multi task operating system for the device controller, and will replace local controllers of slits with sequencers.

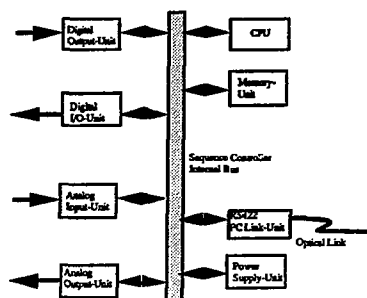

Fig. 6 Sequencer System

#### Acknowledgement

The authors would like to thank Prof. Gen'ichi Horikoshi and Prof. Akira Asami for their support, as well as the members of the PF Linac.

#### Reference

- [1], T. Shidara et al., "Improvement on Monitor System in the KEK 2.5-GeV Linac", KEK-Report-88-11, January 1989.
- [2], K. Furukawa et al., "Recent Progress in the Control System of the KEK 2.5-GeV  $e^-/e^+$  Linac", Nucl. Inst. and Meth. A293(1990)16-22.
- [3], M. Yokota et al., "New Power Supplies for PF Linac Electron Guns and their Control", Proc. of the 16th Linac Meeting, Nihon Univ., P. 212-214, September 1991.
- [4], "KEK Photon Factory Activity Report", 1990.
- [5], K. Kakihara et al., "Energy Slit System for the PF 2.5-GeV Linac", Proc. of the 7th Symposium on Accelerator Science and Technology, P. 231-233, Osaka, December 1989.
- [6], "Hardware Manual of FC-9801V in Japanese", (NEC, 1989).
- [7], "Hardware Manual of C200H in Japanese", (OMRON, 1989).

#### C. Sequence controllers?

For designing the device controllers, great care should be paid to the large noise caused by the high-voltage pulse (about 100 kV and 2  $\mu$ s) of the gun pulser. Therefore, the sequencer was used for the device controller; it has a CPU, an analog I/O, a digital I/O and a communication link and power supply units. A block diagram of the high-voltage dome controller is shown in Fig. 6. The capability of the individual units for the environmental acceptance has been improved as in the case of the FC-9801V. For example, the digital I/O-unit uses an optical coupled I/O, and the analog I/O-unit uses a differential I/O.

The program for the sequencer can be written as a ladder circuit diagram, which has been widely used to design a relay circuit. Furthermore, it can be handled and programmed on the FC-9801V. We can examine the sequencer's program by on-line checking from the FC-9801V. This is very convenient for reading, writing and checking programs.