

Risk-Based Systems Analysis of Emerging High-Level Waste Tank Remediation Technologies

Executive Summary

B. B. Peters
R. J. Cameron
W. D. McCormack
C. A. Olmstead
L. G. Rivero
C. L. Susiene
R. L. Treat
T. L. Trenkler
A. J. Watts
Enserch Environmental Corporation

K. M. Fowler
M. J. Quadrel
Pacific Northwest Laboratory

J. M. Cruse
Westinghouse Hanford Company

Date Published
August 1994

Prepared for the U.S. Department of Energy
Office of Environmental Restoration
and Waste Management



**Westinghouse
Hanford Company**

P.O. Box 1970
Richland, Washington 99352

Hanford Operations and Engineering Contractor for the
U.S. Department of Energy under Contract DE-AC06-87RL10930

Approved for Public Release

MASTER

ep
DISTRIBUTION OF THIS DOCUMENT IS UNLIMITED

DISCLAIMER

This report was prepared as an account of work sponsored by an agency of the United States Government. Neither the United States Government nor any agency thereof, nor any of their employees, make any warranty, express or implied, or assumes any legal liability or responsibility for the accuracy, completeness, or usefulness of any information, apparatus, product, or process disclosed, or represents that its use would not infringe privately owned rights. Reference herein to any specific commercial product, process, or service by trade name, trademark, manufacturer, or otherwise does not necessarily constitute or imply its endorsement, recommendation, or favoring by the United States Government or any agency thereof. The views and opinions of authors expressed herein do not necessarily state or reflect those of the United States Government or any agency thereof.

DISCLAIMER

Portions of this document may be illegible in electronic image products. Images are produced from the best available original document.

RELEASE AUTHORIZATION

Document Number: WHC-EP-0782, Revision 0
Volume 1

Document Title: Risk-Based Systems
Analysis of Emerging High-Level Waste Tank
Remediation Technologies
Executive Summary

Release Date: August 25, 1994

* * * * *

**This document was reviewed following the
procedures described in WHC-CM-3-4 and is:**

APPROVED FOR PUBLIC RELEASE

* * * * *

WHC Information Release Administration Specialist:

M. Boston

(Signature)

M. N. Boston

8/25/94

(Date)

Document Title: Risk-Based Systems Analysis of Emerging
High-Level Waste Tank Remediation Technologies

Prepared by: R. J. Cameron
J. M. Cruse
K. M. Fowler
W. D. McCormack
C. A. Olmstead
B. B. Peters
M. J. Quadrel
L. G. Rivero
C. L. Susiene
R. L. Treat
T. L. Trenkler
A. J. Watts

Approved by:

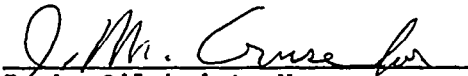
R. L. Gilchrist, Manager
Technology Demonstration Programs

8/24/94
Date

This page intentionally left blank.

CONTENTS

1.0	INTRODUCTION	1
2.0	SYSTEM ANALYSIS MODEL	6
2.1	SYSTEM CHARACTERIZATION	7
2.2	RISK EVALUATIONS	7
2.3	COST CALCULATIONS	10
2.4	SYSTEM ANALYSIS MODEL SOFTWARE	10
3.0	BASELINE AND TRIAL APPLICATIONS	12
4.0	SUMMARY AND CONCLUSIONS	25
5.0	REFERENCES	26

LIST OF FIGURES

1	Technology Funding Decision Making Process.	3
2	System Risk Analysis Model Process	4
3	Additional Stakeholder Values.	5
4	System Analysis Model Software Flow Chart.	11
5	Tank Waste Remediation System New Technical Strategy.	13
6	Base Case Top-Level Flow Diagram.	14
7	Comparison of UST-ID Funding to Selected Risks Evaluated for Thirteen Base Case Modules.	16
8	Base Case Costs (Percentage of Overall System Costs).	19
9	Test Case I Costs (Percentage of Overall System Costs).	21
10	Test Case II Costs (Percentage of Overall System Costs).	23

LIST OF TABLES

1	Unit Operation Descriptions	8
2	Module Contributions to Risk and Cost — Base Case	15
3	Test Case Changes to System Risk and Cost from the Base Case	17

LIST OF TERMS

D&D	decontamination and decommissioning
DOE	U.S. Department of Energy
DST	double-shell tank
EPA	U.S. Environmental Protection Agency
HI	hazard index
HLW	high-level waste
LLW	low-level waste
MEI	maximally exposed individual
NEPA	National Environmental Policy Act (1969)
OTD	Office of Technology Development
PPG	Priority Planning Grid
RWTRTFA	Radioactive Waste Tank Remediation Technology Focus Area
SST	single-shell tank
TNPW	total net present worth
TWRS	Tank Waste Remediation System
UST-ID	Underground Storage Tank - Integrated Demonstration
VOC-Arid ID	Volatile Organic Compounds - Arid Integrated Demonstration

Metric Conversion Chart

The following chart is provided to the reader as a tool to aid in converting to metric units.

Into Metric Units			Out of Metric Units		
<u>If You Know</u>	<u>Multiply By</u>	<u>To Get</u>	<u>If You Know</u>	<u>Multiply</u>	<u>To Get</u>
Length			Length		
inches	25.4	millimeters	millimeters	0.039	inches
inches	2.54	centimeters	centimeters	0.394	inches
feet	0.305	meters	meters	3.281	feet
yards	0.914	meters	meters	1.094	yards
miles	1.609	kilometers	kilometers	0.621	miles
Area			Area		
sq. inches	6.452	sq. centimeters	sq. centimeters	0.155	sq. inches
sq. feet	0.093	sq. meters	sq. meters	10.76	sq. feet
sq. yards	0.0836	sq. meters	sq. meters	1.196	sq. yards
sq. miles	2.6	sq. kilometers	sq. kilometers	0.4	sq. miles
acres	0.405	hectares	hectares	2.47	acres
Mass (weight)			Mass (weight)		
ounces	28.35	grams	grams	0.035	ounces
pounds	0.454	kilograms	kilograms	2.205	pounds
short ton	0.907	metric ton	metric ton	1.102	short ton
Volume			Volume		
teaspoons	5	milliliters	milliliters	0.033	fluid ounces
tablespoons	15	milliliters	liters	2.1	pints
fluid ounces	30	milliliters	liters	1.057	quarts
cups	0.24	liters	liters	0.264	gallons
pints	0.47	liters	cubic meters	35.315	cubic feet
quarts	0.95	liters	cubic meters	1.308	cubic yards
gallons	3.8	liters			
cubic feet	0.028	cubic meters			
cubic yards	0.765	cubic meters			
Temperature			Temperature		
Fahrenheit	subtract 32, then multiply by 5/9	Celsius	Celsius	multiply by 9/5, then add 32	Fahrenheit
Pressure			Pressure		
inches of H ₂ O	0.00246	atmospheres	atmospheres	406.5	inches of H ₂ O
inches of Hg	0.03332	atmospheres	atmospheres	30.005	inches of Hg

**RISK-BASED SYSTEMS ANALYSIS OF EMERGING HIGH-LEVEL
WASTE TANK REMEDIATION TECHNOLOGIES**

1.0 INTRODUCTION

This report describes a System Analysis Model developed under the U.S. Department of Energy (DOE) Office of Technology Development (OTD) Underground Storage Tank-Integrated Demonstration (UST-ID) program to aid technology development funding decisions for radioactive tank waste remediation. DOE has established the Radioactive Waste Tank Remediation Technology Focus Area (RWTRTFA) to identify and develop new technologies that will reduce the risk and/or cost of remediating DOE underground waste storage tanks and tank contents. There are, however, many more technology investment opportunities than the current budget can support. Current technology development selection methods evaluate new technologies in isolation from other components of an overall tank waste remediation system. These methods do not show the relative effect of new technologies on tank remediation systems as a whole. Consequently, DOE may spend its resources on technologies that promise to improve a single function but have a small or possibly negative, impact on the overall system, or DOE may overlook a technology that does not address a high priority problem in the system but that does, if implemented, offer sufficient overall improvements. Systems engineering and detailed analyses often conducted under the National Environmental Policy Act (NEPA 1969) use a "whole system" approach but are costly, too time-consuming, and often not sufficiently focused to support the needs of the technology program decision-makers. An alternative approach is required to evaluate these system impacts but still meet the budget and schedule needs of the technology program.

The approach demonstrated in this report is based on a limited systems analysis. This System Analysis Model combines elements of cost-effectiveness and systems analysis. The premise underlying the development of this model is that technology development decisions should be based on a disciplined assessment of the overall risks associated with a total remediation system and that the value of new technologies is their potential to reduce those overall risks at a reasonable cost. At the same time, the importance of quick turnaround and flexibility is acknowledged: it is not in the scope of the System Analysis Model to establish or recreate systems analysis on a scale that may be undertaken by programs responsible for implementing technologies for tank remediation. The objective of this model is instead to provide comparative risk and cost assessment data for baseline and alternate tank remediation cases, where alternate cases are created by substituting or adding emerging demonstration technologies to the baseline.

The key to a successful assessment is to conduct (1) sufficient systems modeling to provide a reliable basis for overall system performance assessments, (2) sufficient cost analysis to measure significant variations in costs, and (3) sufficient risk analysis to estimate significant variations

in worker and public risk. Only a minimum set of critical variables can be assessed to support the limited budget and time constraints for decision-making.

Another important objective of this analysis is to make the model "user friendly" so that it can be used online in discussions with stakeholders (including technical advocates, regulators, interested public, industry, or users). In this application the model could be used to quickly examine the relative value of alternate technologies in the context of a complete remediation system. Feedback from the stakeholders will allow proposers of new technologies to identify performance issues they must address to show that the technology would have a positive net benefit to the system. It will also open a dialogue among participants in the tank remediation decision process and provide a basis for reasoned discussion of new technical options.

In this version (Rev. 0), a "demonstration model" for system analysis is presented. It addresses worker and public health risks (Volume II, Section 2.2) and costs (Volume II, Section 2.3). Later versions would include other programmatic risks, such as schedule, compliance, environmental risks, and stakeholder values. The risk assessments provided by the model will, ideally, be considered with other important decision-making criteria, including the set of stakeholder values that might discriminate among technical options. In a real decision-making context, it should be possible to combine the assessments of all criteria, examine different weighting factors for the criteria, and generate summary assessments for different configurations of an overall tank remediation system given alternate technologies. This process is shown in Figure 1. The steps involved in the System Analysis Model are shown in Figure 2. Figure 3 shows additional decision criteria that might be considered in a full evaluation of innovative technologies. These are summarized from a series of interviews conducted with stakeholders and regulators through the Volatile Organic Compounds - Arid Integrated Demonstration (VOC-Arid ID).¹ Variables currently provided by the model are shown in bold. Once expanded, the model could also address schedule impacts (associated with the effectiveness criterion), regulatory compliance, and possibly environmental impacts. Judgements of performance and socio-political impacts would be provided separately by technologists or other stakeholders.

The ultimate value of this model is to provide decision-makers with a tool for identifying development efforts which, if successful, would provide significant overall benefit in terms of minimizing system cost and risk and thus have high priority for funding. The scope of the work described in this report was to develop and demonstrate this decision tool. This demonstration focuses on one baseline configuration (the Hanford Site Tank Waste Remediation System [TWRS] reference system) and two alternate configurations using new technologies (robotic sluicing instead of traditional sluicing, and subsurface

¹Other surveys of public and stakeholder values have identified as many as nine decision-making criteria for the Hanford Site alone. However, not all of these would discriminate among technology development options. A next step for this model is to identify the critical set of additional decision criteria for funding emerging technology.

Figure 1. Technology Funding Decision Making Process.

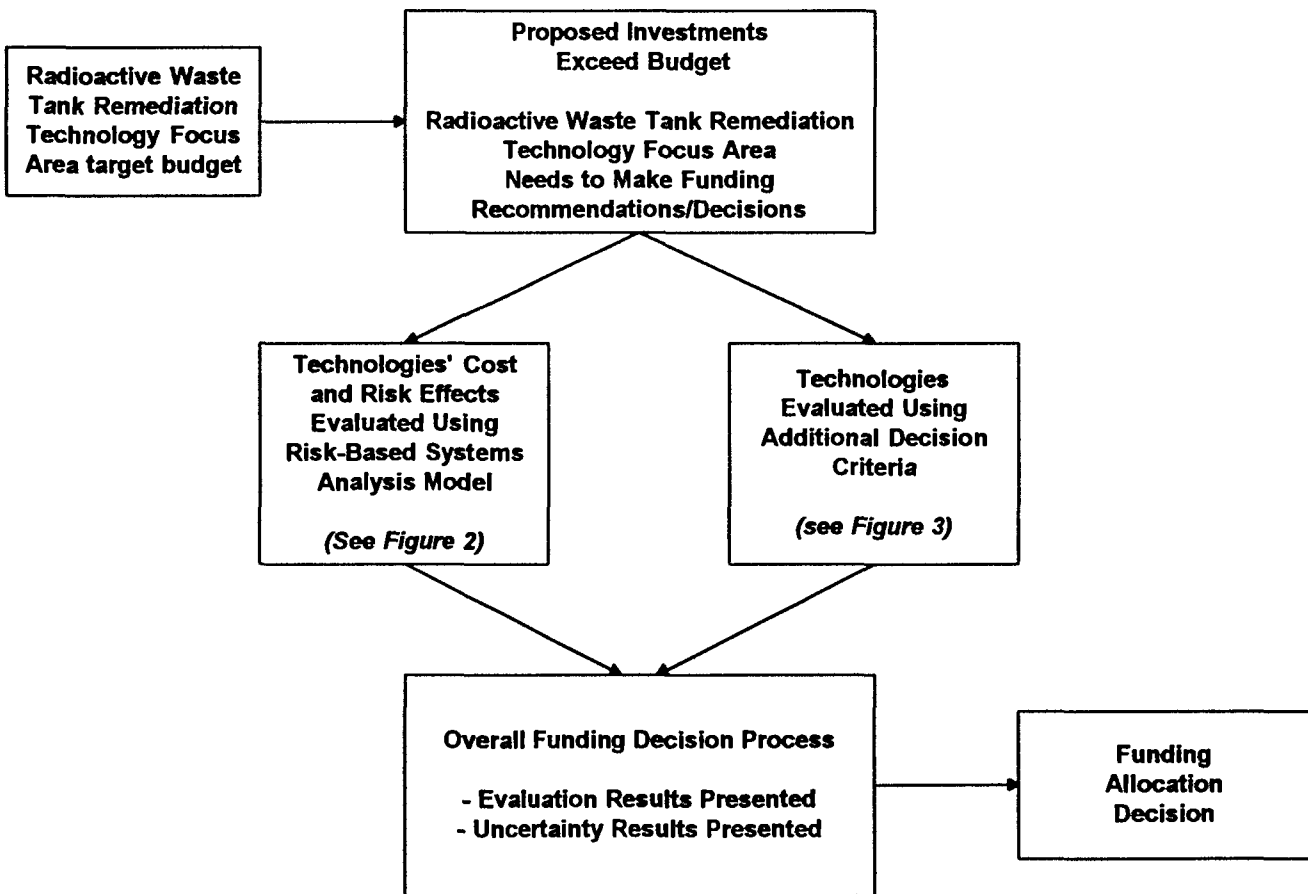

Figure 2. System Risk Analysis Model Process.

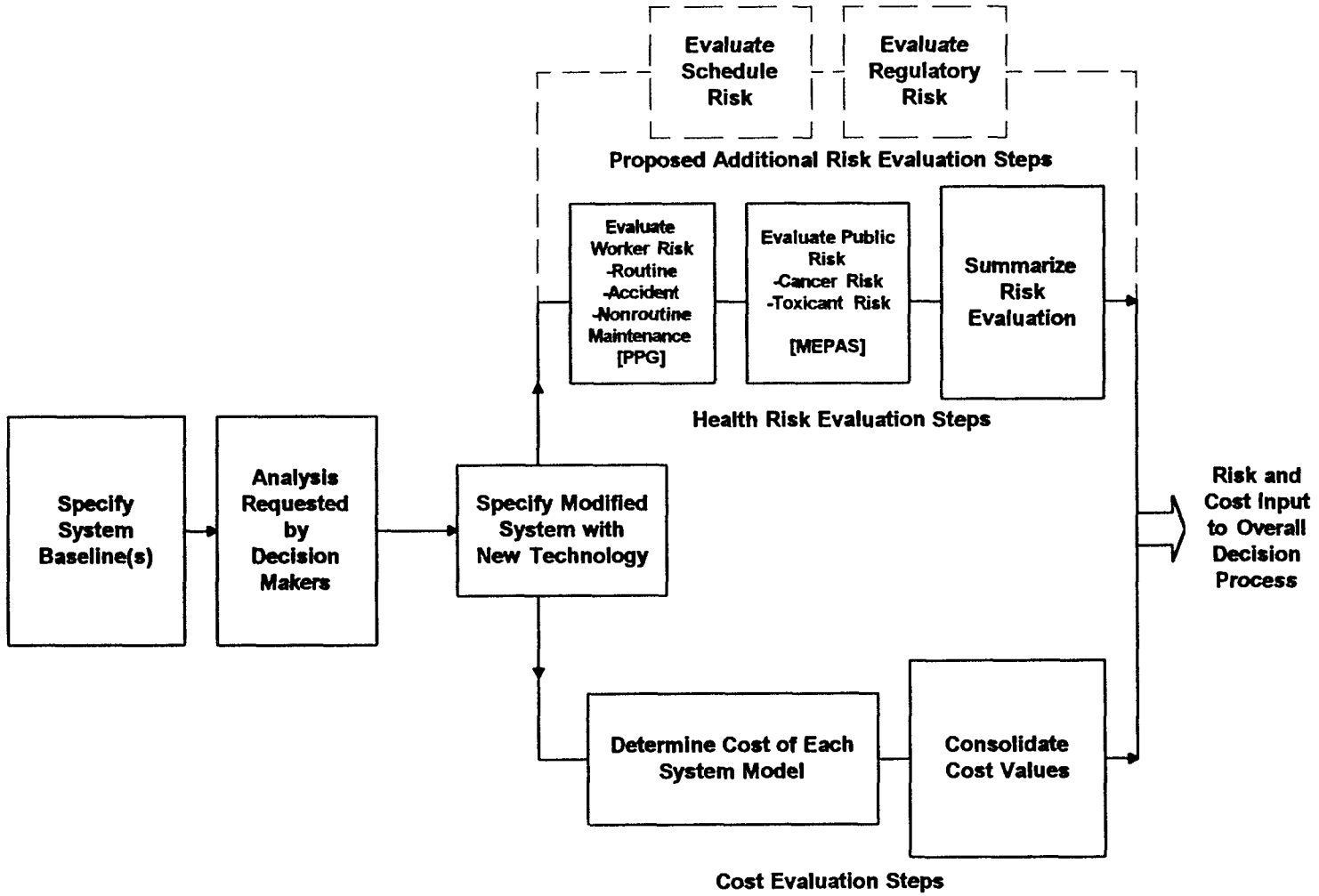
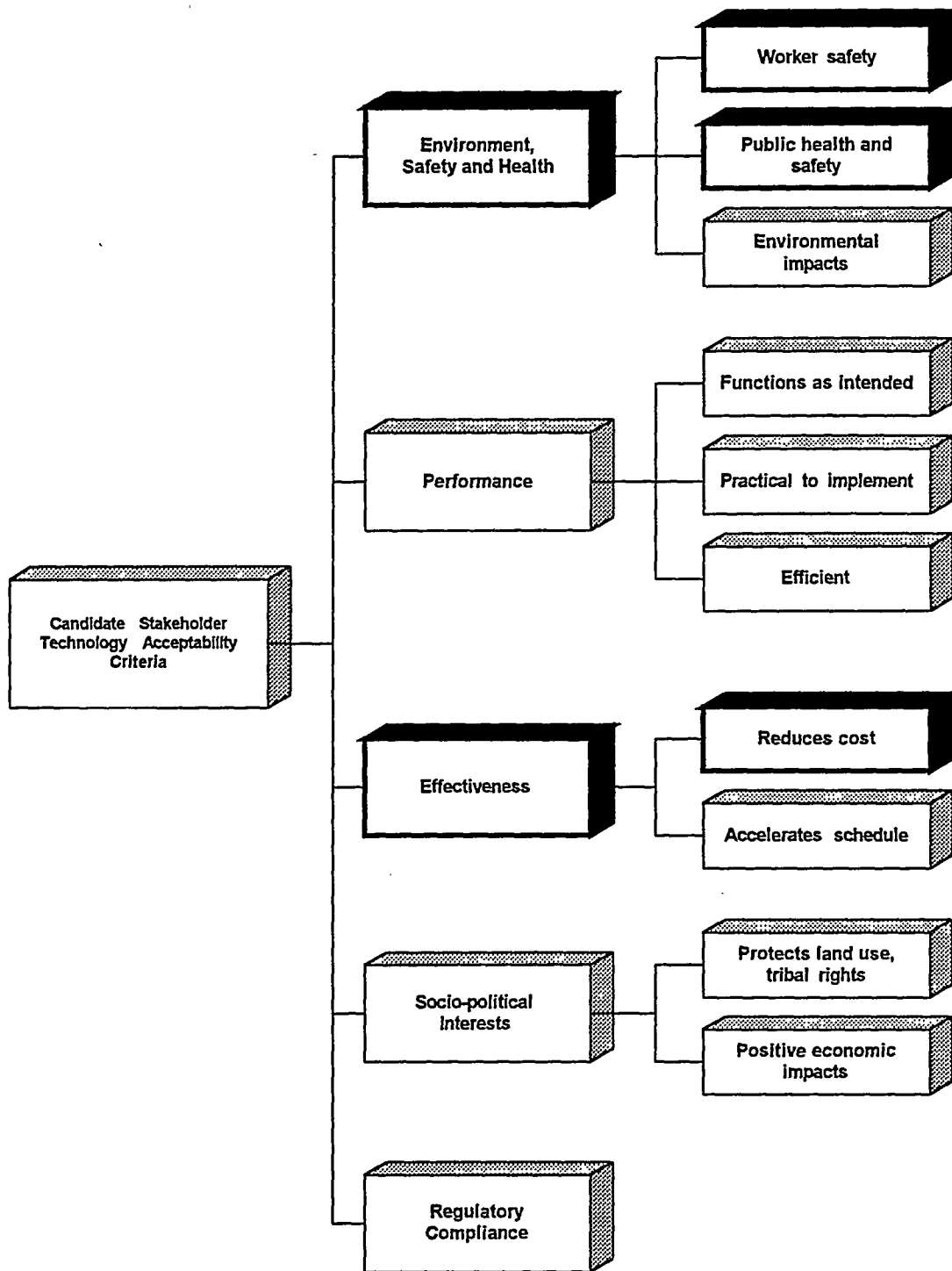

Figure 3. Additional Stakeholder Values.



barriers instead of no barrier during sluicing). Time and budget limitations constrained the choice of analytic tools applied to this demonstration version; as additional risk parameters are added, more sophisticated tools for assessing their value may also be added. The near-term objective was to demonstrate a type of analysis that could be applied to selected technologies to determine whether funding should be initiated or continued. Good candidate technologies for analysis include: subsurface barriers (demonstrated here), robotic sluicing (demonstrated here), full-scale retrieval of tanks and tank waste (e.g., mining), advanced processing concepts (e.g., TRUEX), alternative low-level waste (LLW) forms (e.g., ceramics), and alternative closure technologies (e.g., surface barriers).

After the model has been fully developed, the evaluation of a new technology will take from 1 to 3 months and cost from \$10,000 to \$100,000 depending on the complexity of the technology's impacts to the overall system. If the model works as expected, significant time and cost savings will accrue by avoiding investments in new technologies that offer no advantage in improving cost effectiveness. In addition, the model may identify areas where additional technology development may be needed to improve the overall cost effectiveness of the system.

2.0 SYSTEM ANALYSIS MODEL

A number of factors should be considered when making decisions to provide funding for further development of candidate tank waste remediation technologies. Two important factors are the potential human health risks associated with a technology, and the potential costs associated with implementing, operating, and decommissioning it. Measuring these risks is complicated by the fact that initial funding decisions must be made at a point early in the technology development process, often before there are sufficient design and process data to support quantitative analyses of potential risks or costs. In addition, because tank waste remediation will be accomplished by a complex system of interlinked technologies, the performance of individual technology modules within the system will influence overall system risks and costs.

A System Analysis Model has been developed to demonstrate that it is possible to review the characteristics of candidate technologies early in their development, and to perform systematic, qualitative evaluations of their potential influence on overall tank waste remediation system human health risks and costs. The model was developed to provide a structured and objective method that can be applied consistently and cost effectively in these technology evaluations.

Rather than evaluating individual technologies in isolation, they are evaluated in the context of a complete, multi-technology remediation system. As indicated previously, tank waste remediation will require a complex system of linked technology modules, and alternative technologies implemented within these modules will influence overall system performance. As such, an isolated evaluation may overlook impacts on costs and risks elsewhere in the system,

which should be accounted for in the evaluation of a technology's merits. To address these potential impacts, the System Analysis Model can be used to first develop a baseline evaluation of full-scope remediation system risks and costs, then to reevaluate the full-scope risks and costs with the alternative technology substituted into the system. In this way, alternative technologies are evaluated in light of their costs and benefits to the overall tank waste remediation effort.

Section 2 in Volume II of this report describes the System Analysis Model in more detail.

2.1 SYSTEM CHARACTERIZATION

System characterization is the first step in implementing the System Analysis Model. This step identifies all of the process specific data which feed into the risk and cost assessments.

System characterization requires that all of the major processes and process streams be identified and that an overall material balance be established. The major processes are labeled as unit operations and are grouped into functional groups labeled as modules. Once the modules have been organized into an overall flow diagram, stream flows between modules are identified and labeled.

After the detailed flow diagram is established, a material balance is completed for all critical streams entering and leaving each module in terms of the total liquid mass, total solids mass, total water mass, and mass of contaminants of concern.

It is particularly important that all process streams that discharge to the environment (air or water) be characterized, as these are the primary contributors to the public risk values. In addition, each unit operation is described in terms of the information listed in the categories shown in Table 1. This information is used to estimate routine worker radiation exposure and potential for and severity of accidents associated with each unit operation, under both routine and nonroutine conditions.

The model's modular format provides a mechanism by which new modules can be added or modules can be modified to form test cases. This allows the impacts of new technologies to be incorporated into the model and compared with the baseline.

2.2 RISK EVALUATIONS

The objective of the risk calculation in the model is to provide a consistent basis for qualitatively evaluating the potential influence that alternative technology modules may have on overall health risks associated with the remediation system. Calculation methods have been selected to be consistent with the fact that they will be applied early in the technology evaluation process, when limited or only qualitative information will be available regarding technology characteristics. The calculation methods that

Table 1. Unit Operation Descriptions.

Required information
General Description Number of Individual Components (tanks, pumps, filters etc.) Size/Capacity of Each Component (m, m ² , m ³) Unit Operation Lifetime (years) Operating Efficiency (%) Radiation Level (High, Low, Cold) Total Direct Labor Man-hours (hours) Temperature (°C) Pressure (psi) pH/Acidity/Alkalinity Energetic Reaction Potential (seven categories from Very Low to Very High) Process Stability (High, Medium, Low) Waste Form (solid, liquid, gas) Solids in Waste (%) Organics in Waste (%) Flammability (seven categories from Very Low to Very High) Number of (HL ^a , LL ^b , & Cold) Mechanized Parts per Unit Number of (HL ^a , LL ^b , & Cold) Isolated Process Steps per Unit Number of Installation Activities (e.g. install 20 mixer pumps) Number of Items Requiring Decontamination Number of Items Requiring Decommissioning and Disposal

^aHL = high-level, assumed to require remote handling.
^bLL = low-level, assumed to allow contact handling.

have been implemented for this demonstration model were selected for their ease of application and familiarity; they may (and, in some cases, should) be further reviewed and modified. However, the model and associated risk calculations are sufficiently complete to permit their trial application and evaluation as a mechanism for supporting future assessments of candidate tank waste remediation technologies.

Several different health risk products are calculated. In the case of workers, health-related impact is evaluated in the context of radiation dose to individual members of the work force. Radiation dose was selected because it is a common measure of worker impact, is thoroughly addressed by DOE criteria, and is well-documented in the records of past facility operations of a similar nature. In the case of the public, health-related impact is addressed in the context of a maximally exposed individual's (MEI)
 (1) incremental increase in risk (probability) of death from cancer, and
 (2) hazard index (HI), which is the ratio of calculated toxic material exposure to the toxic material reference doses. An individual receptor and these quantities were selected because they are standard measures of public health impact, are adequately addressed in DOE and U.S. Environmental

Protection Agency (EPA) criteria, and are applicable to both radiological and hazardous material. Routine risks to the public are evaluated for the MEI rather than a collective population for the following reasons: (1) risks and HI for an MEI are a standard measure for human health effects, (2) there is no established method for computing population risks for noncarcinogenic chemicals that provides meaningful results, (3) all risk and noncancer hazard values should be based on the same receptor characteristics for comparative purposes, and (4) individual and population risks associated with exposure to radionuclides, chemical carcinogens, and chemical noncarcinogens are expected to be consistent.

An alternative approach was selected to address worker and public health-related impact associated with potential failure conditions. Standard safety analysis procedures exist for the identification and evaluation of potential failure events. However, to be useful, these procedures require a reasonably detailed level of facility and process information. Because this information will not be available for these emerging technology evaluations, a subjective approach was selected which relies on expert judgement. For the limited purpose of this trial application and model demonstration, the results are expressed as qualitative frequency consequence values (unitless) that have been derived from selected elements of the relative ranking system implemented in the Priority Planning Grid (PPG). The PPG has established eight levels of consequence (ranks), within which nine impact attributes are compared. The attributes of interest for this model's risk evaluation are public safety, worker safety, environmental contamination, and cost. Because these elements of the PPG are being used outside their original application their use here is subject to ongoing review.²

Risks are calculated separately for two time frames: (1) near-term exposures associated with the active installation and operational phases, and (2) future public exposures associated with residual contamination and disposed wastes following completion of the active operations.

The risk calculations do not currently address the risks of physical injuries that can occur during construction or other industrial activities associated with the installation or operation of the technology. Because these risks can be significant, they will be addressed in future revisions of the model.

Results generated by the risk calculations, while given as discrete numerical quantities, should not be viewed as estimates of actual or potential human health risk associated with the tank waste remediation technologies. The calculation results are intended to support consistent comparative evaluations of the influence that alternative technologies may have on overall

²We have additional methodological concerns with the PPG. These center on the selection of attributes, levels of consequence, and weights given to those levels. Nevertheless, the grid provides a standard for measuring failure conditions across modules and system configurations. Should failure have significant impact on a technology's evaluation, an uncertainty analysis can be performed on the PPG ratings to determine how robust the results are to these pre-established judgements.

system risk, and should be viewed as qualitative estimates only. Further, the calculational methods themselves are general, and are not the methods that would be used when performing a quantitative human health risk assessment based on more complete and quantitative inputs.

2.3 COST CALCULATIONS

Cost information is required to provide a basis for direct comparisons of alternatives in terms of overall cost and cost-benefit. Benefit can be measured in terms of risk reduction. Risk reduction is obtained at an increased overall cost. Often, conversely, a system change that results in a reduction in cost will often increase the inherent risk (operational or health effects) of the overall system. All costs are converted into Total Net Present Worth (TNPW) and 1994 dollars. The complete waste retrieval, treatment, and decontamination and decommissioning (D&D) process is assumed to take 13 years (10 years processing and 3 years D&D). A 10% discount rate was assumed for conversion of costs to TNPW.

Due to the nature of the high-level waste (HLW) tank technology program, technologies that need to be evaluated are usually at some preliminary stage in their development. For this reason, system characterization and cost data are usually minimal or may be nonexistent. The data required for cost and risk analysis of new technologies must be estimated using best engineering judgement, which often results in order-of-magnitude quality estimates. Relatively simple risk and cost estimating software, coupled with an uncertainty analysis, is appropriate considering the high uncertainties in risk and cost input data.

2.4 SYSTEM ANALYSIS MODEL SOFTWARE

The System Analysis Model Software is a linked system of Microsoft Excel 4.0³ spreadsheets that provide the user with a computerized directory of the flow processes being evaluated by the model. By using the mouse to click on a series of buttons or menu items, the user can call up a particular case (i.e., the Base Case, Test Case I, or Test Case II), display a complete flow diagram of any module within the given case, and then find out more information on the module and any unit operations within the module. Available information also includes the set of assumptions used to characterize the module, details of the mass balance at that point in the model, and results of the risk and cost analysis. This layered information system, which displays only as much information as required by the user, will allow the user to easily compare modules, unit operations, and risk/cost analyses results for different system configurations. It also provides access to any of the critical assumptions or parameters, making the process transparent. This serves as both educational and negotiation purposes: nonexperts can view the critical parameters throughout the model and experts can test alternative assumptions or judgements of performance. The software flow chart is provided as Figure 4.

³Microsoft Excel 4.0 is a trademark of Microsoft Corporation.

Figure 4. System Analysis Model Software Flow Chart.

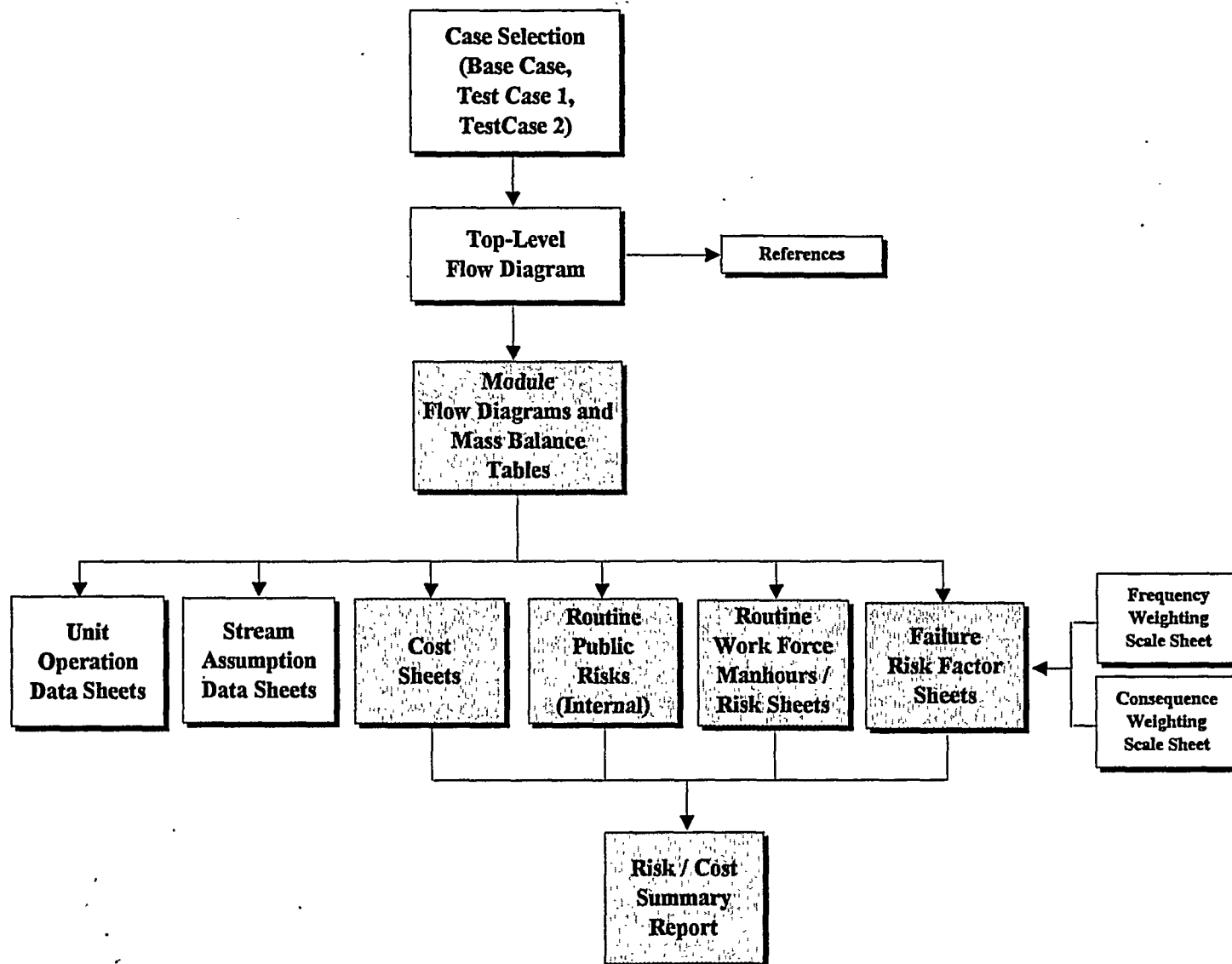

USED FOR INFORMATIONAL PURPOSES ONLY

USED IN RISK AND/OR COST CALCULATIONS

3.0 BASELINE AND TRIAL APPLICATIONS

The System Analysis Model was used to establish a baseline assessment for the Hanford Site TWRS. Two test cases were also assessed to provide examples of how this model can be used as a decision-making tool.

The TWRS new technical strategy top-level flow diagram (Figure 5) was the basis for determining the system configuration for the Base Case. This flow diagram was reconfigured into the modular format required for the cost and risk analytical approach described in Section 2 (Figure 6). A Base Case was established that incorporates technologies currently planned for removing, treating, and disposing of the tank wastes, and the D&D of the tanks and associated facilities into a complete remediation system. This system provides the baseline for comparing the relative costs and risks of alternative technologies.

Traditional sluicing is the method of retrieving waste from single-shell tanks (SST) evaluated for the Base Case as well as for the first test case (Test Case I). However, in Test Case I, it was assumed that a close-coupled chemical subsurface barrier would be used in conjunction with traditional sluicing. Both the OTD and TWRS have invested in alternate barrier technologies. This addition would impact both the cost and risk of Test Case I in comparison to the Base Case.

The second test case (Test Case II) would affect tank waste retrieval using robotic sluicing with a bridge-mounted confinement structure. No subsurface barriers would be used in Test Case II. Robotic sluicing is a variation of robotic armed-based retrieval systems that were first investigated at the Hanford Site in the mid-1970s; it has been funded by the OTD for the last four years, and is currently being considered as a viable retrieval method.

The relative contributions of each module to the Base Case system risk and cost are shown in Table 2. This breakout of risk by system module allows for at least two preliminary analyses of the Base Case. Figure 7 shows where the greatest relative health risks are across modules in the system. Of the seven risks presented, three account for most of the system health risk: disposal phase cancer risk, disposal phase toxicant HI, and accident risk. These three risks were chosen as representative of public and worker risk because they likely are the primary contributors to public exposure and catastrophic worker exposure, regardless of the technology. Operations associated with SST Waste Retrieval (module M.1), LLW glass formation (module M.5), and HLW glass formation (module M.8) have the greatest change of accident risks. Operations associated with SST and double-shell tank (DST) waste retrieval (modules M.1 and M.2) carry the greatest cancer risks.

Figure 7 also shows current (fiscal year 1994) technology funding levels plotted against these risks, to demonstrate the correlation between funding and remediation risk. The risks are presented as a percentage of the total of each risk and are graphed against the UST-ID funding levels for projects related to each module. The UST-ID program is currently investing heavily into the development of characterization and safety (tank surveillance) technologies, including leak detection, in-tank waste characterization, and

Figure 5. Tank Waste Remediation System
New Technical Strategy.

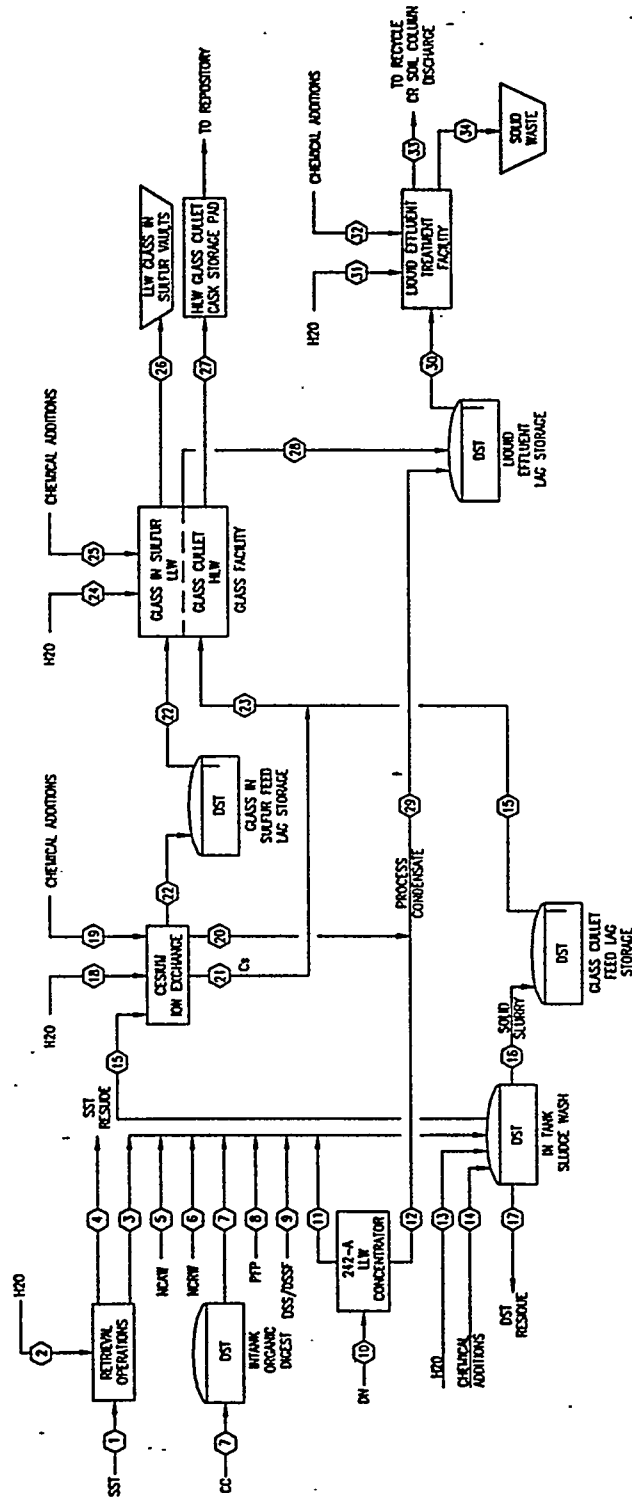

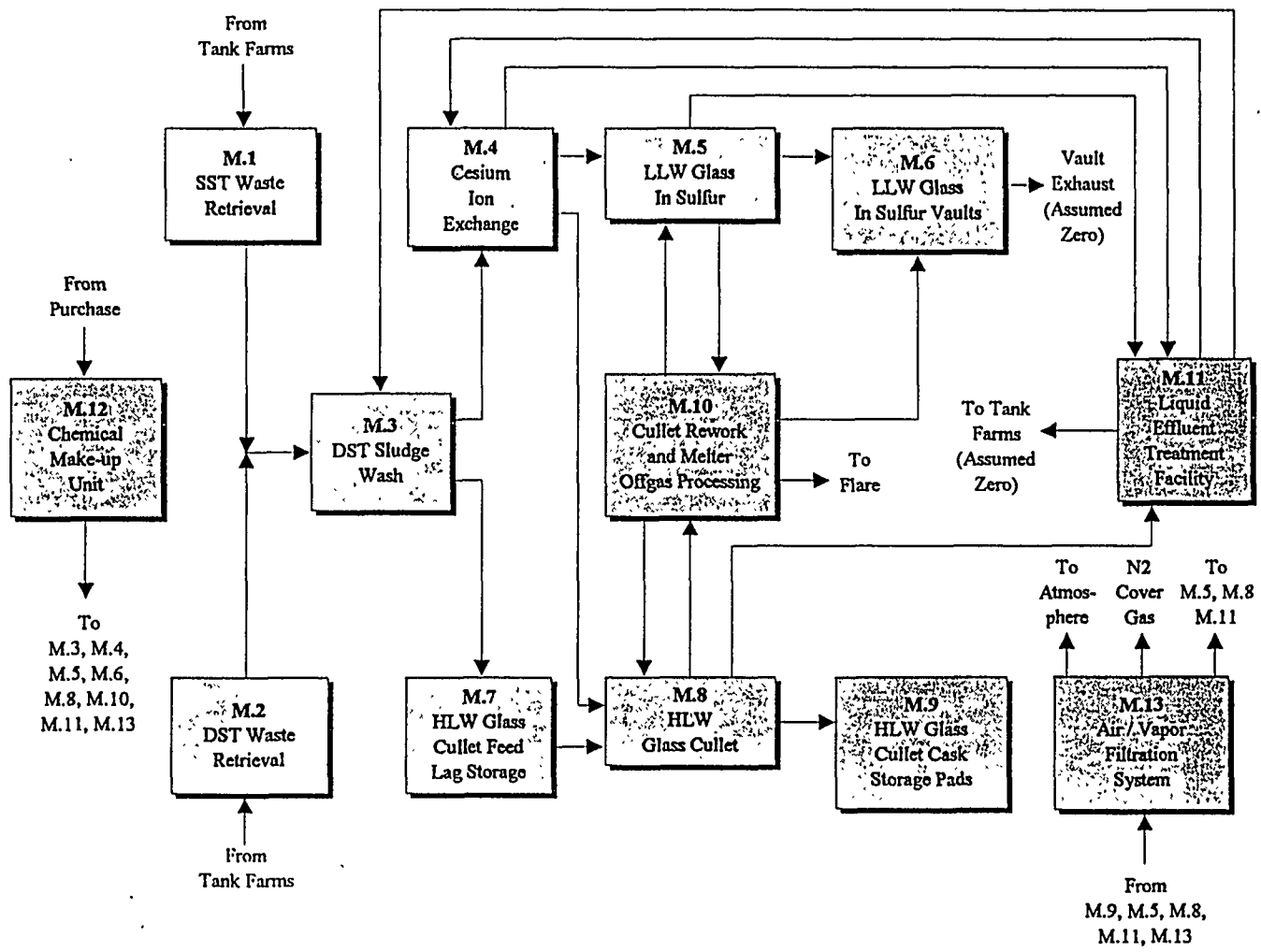

Figure 6. Base Case Top-Level Flow Diagram.

Table 2. Module Contributions to Risk and Cost - Base Case.

Risk Element	Modules													Total Contribution by Element	
	M.1 SST Waste Retrieval	M.2 DST Waste Retrieval	M.3 DST Sludge Wash	M.4 Cesium Ion Exchange	M.5 LLW Glass In Sulfur	M.6 LLW Glass In Sulfur Vaults	M.7 HLW Lag Storage	M.8 HLW Glass Cullet	M.9 HLW Glass Storage Pad	M.10 Rework and Offgas	M.11 Liquid Effluent Treatment	M.12 Chemical Make-up Unit	M.13 Air/Vapor Filtration System		
Operational Phase Public Cancer Risk	—	—	—	—	—	—	—	—	—	—	—	—	100%	100%	
Disposal Phase Public Cancer Risk	79%	21%	—	—	—	—	—	—	—	—	—	—	—	100%	
Operational Phase Public Toxicant Hazard Index	—	—	—	—	—	—	—	—	—	—	—	—	100%	100%	
Disposal Phase Public Toxicant Hazard Index	91%	9%	—	—	—	—	—	—	—	—	—	—	—	100%	
Collective Routine Worker Radiation Dose	18%	4%	9%	10%	9%	7%	6%	11%	10%	6%	6%	—	3%	100%	
Accident Risk	29%	3%	< 1%	3%	29%	< 1%	3%	29%	< 1%	< 1%	< 1%	1%	< 1%	100%	
Nonroutine Maintenance Risk	4%	4%	< 1%	1%	28%	9%	2%	38%	< 1%	10%	< 1%	2%	1%	100%	
Cost Element	Total Net Present Worth	11%	4%	3%	5%	12%	4%	< 1%	28%	25%	5%	< 1%	< 1%	2%	100%

— Non Contributor

Figure 7. Comparison of UST-ID FY 1994 Funding to Selected Risks Evaluated for Thirteen Base Case Modules.

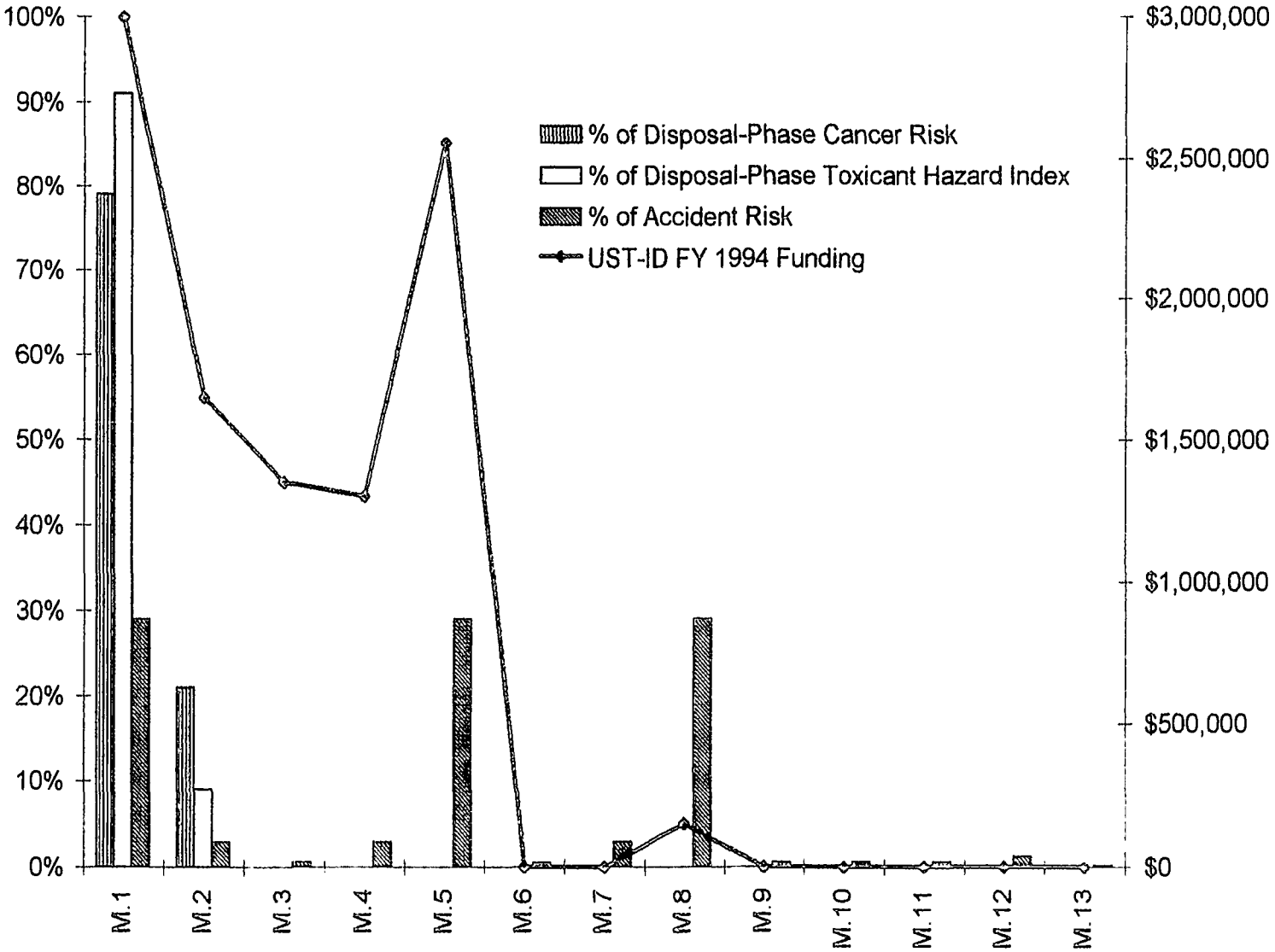

tank waste and structure surveillance (the Light-Duty Utility Arm). These technologies cannot be assessed using the current model. Future development would be necessary to expand the Base Case to include these "pre-processing" modules. Systems studies, such as the advanced processing assessment ("clean option") and this modeling activity, are also not included.

Remaining investments map relatively well against level of expected risk in the system. The UST-ID is investing heavily in remote retrieval technologies, where the greatest proportion of disposal phase cancer risk and toxic hazard lies. (These investments are also driven by regulatory compliance criteria addressing the level of waste that must be removed from the tank.) The UST-ID investment in retrieval technologies will increase in fiscal year 1995. If characterization and safety investments were graphed, Figure 7 would show an even greater amount directed at reducing retrieval risk indirectly through accurate tank surveillance and mapping technologies.

Innovations in LLW processing (module M.4), while correlated with accident risk in the graph, are actually intended to reduce the cost and long-term public health hazard associated with the current LLW glass form. Process modifications in other modules (M.3 and M.4), however, will affect not only the risk and cost of those modules, but also the risk and costs of successive modules. Specifically, the cost spent on cesium removal technologies (module M.4) will directly reduce the risk of LLW processing (module M.5), where a significant portion of accident risk resides (by increasing the extent to which the LLW stream may be contact handled). The dollars spent on sludge washing technologies (module M.3) may significantly reduce overall cost of the system by reducing the amount of HLW that must be processed and stored.

When fully developed, an output of this model would show correlations in spending with a full range of investment drivers, including cost, schedule, and regulatory risks associated with each module.

The results from the System Analysis Model of the Base Case, Test Case I, and Test Case II are shown in Table 3.

Table 3. Test Case Changes to System Risk and Cost from the Base Case.

Element	Test Case I (barriers)	Test Case II (robotic)
Risk element		
Operational phase public cancer risk	--	--
Disposal phase public cancer risk	-41%	-52%
Operational phase public toxicant hazard index	--	--
Disposal phase public toxicant hazard index	-47%	-61%
Collective worker routine radiation dose	+2%	+27%
Accident risk	<1%	<1%
Nonroutine maintenance risk	<1%	+2%
Cost element		
Total net present worth	+24%	+19%

Table 3 shows, for example, that Test Case I (close-coupled barrier) promises to reduce by 41% the chance that the MEI will get cancer, reduce by 47% the chance that the MEI will be harmed by toxicants, increase by <1% the accident risk, and increase by 2% the collective routine worker radiation dose. These reductions are achieved at a 24% increase in cost, or an addition of \$3,300,000,000. In contrast, at slightly less cost increase (19%, or \$2,500,000,000), Test Case II (robotic sluicing) may provide relatively greater risk reductions to the public.

Note that the model does not currently provide a method for directly comparing cost to unit of risk reduction. That is, it is not possible to directly answer the question, "is this reduction in risk worth the cost of technology development?" First, because the measured risks are relative and not absolute, the question lacks external validity. We cannot confidently conclude from the level of analysis in the model that barriers will reduce the incidence of cancer by a specific amount, only that it will do so to a greater or lesser extent than will the baseline. Second, the model does not currently incorporate utility functions for cost and risk such that the two can be directly related. Instead, the model provides useful guidance regarding the relative benefit of alternative investments and helps us to answer the following question: "given several investment opportunities, which appear to reduce risk at the least cost?" Once other decision variables are incorporated into the model or into the decision process more generally, this information should help to prioritize technology investment options in a manner that is both systematic and defensible.

Cost breakdowns for the Base Case and Test Cases I and II are shown in Figures 8, 9, and 10. These figures show the capital cost, labor cost, and disposal costs for each module as a percentage of the total system cost. As seen, the primary differentiation between the Base Case and the test cases is in the module M.1, SST Waste Retrieval capital costs. Any assumptions that impact the retrieval capital cost estimates will directly impact the evaluation. The SST Waste Retrieval capital costs for the two test cases are approximately three times larger than for the Base Case. Therefore it is unlikely that changing capital cost assumptions will alter the conclusion that the use of subsurface barriers or robotic sluicing is significantly more expensive than the Base Case traditional sluicing. Cost details are provided in Sections 3.1, 3.2, and 3.3 of Volume II, and in the appendixes.

Figure 8. Base Case Costs (Percentage of Overall System Costs).

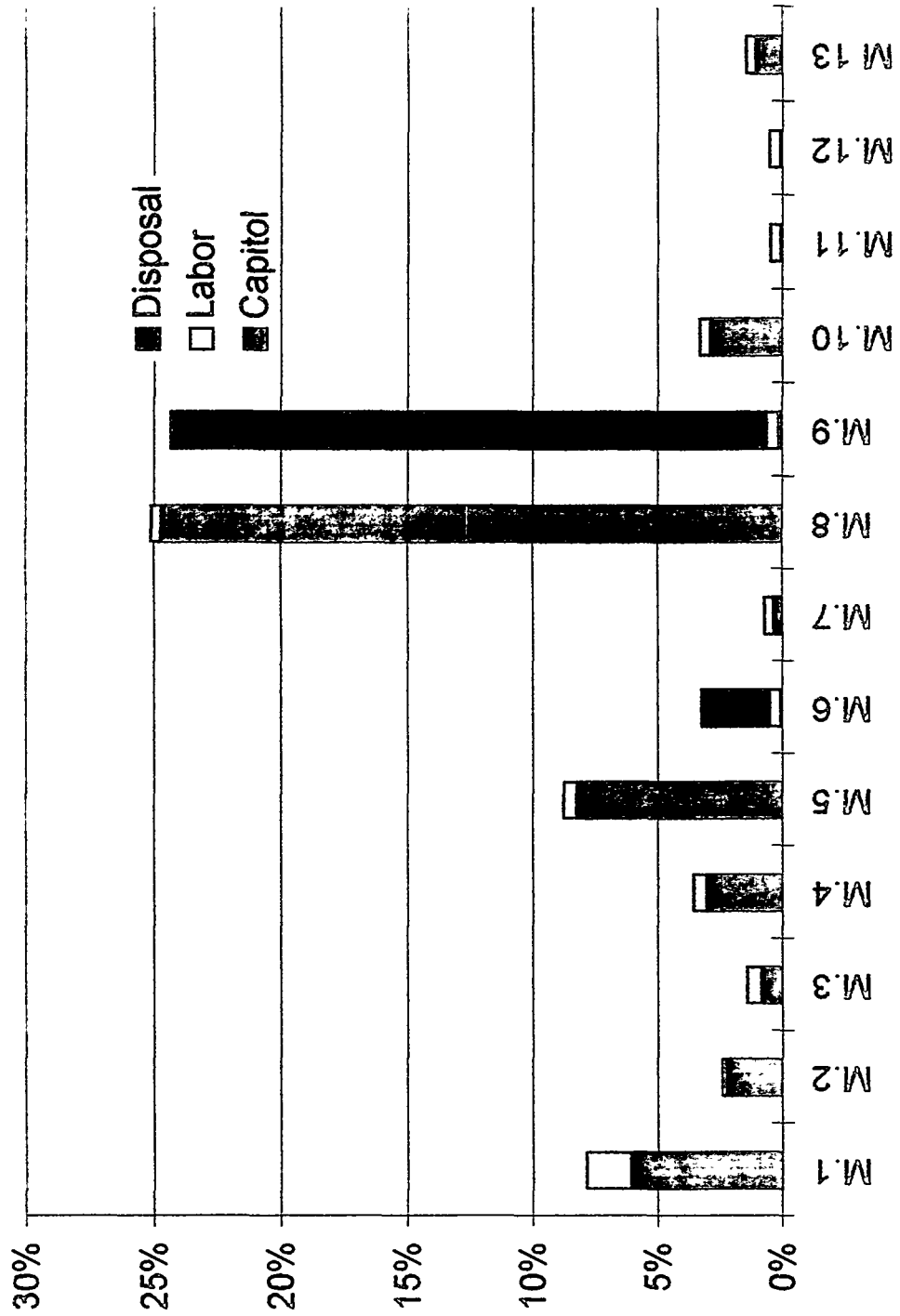

This page intentionally left blank.

Figure 9. Test Case I Costs (Percentage of Overall System Costs).

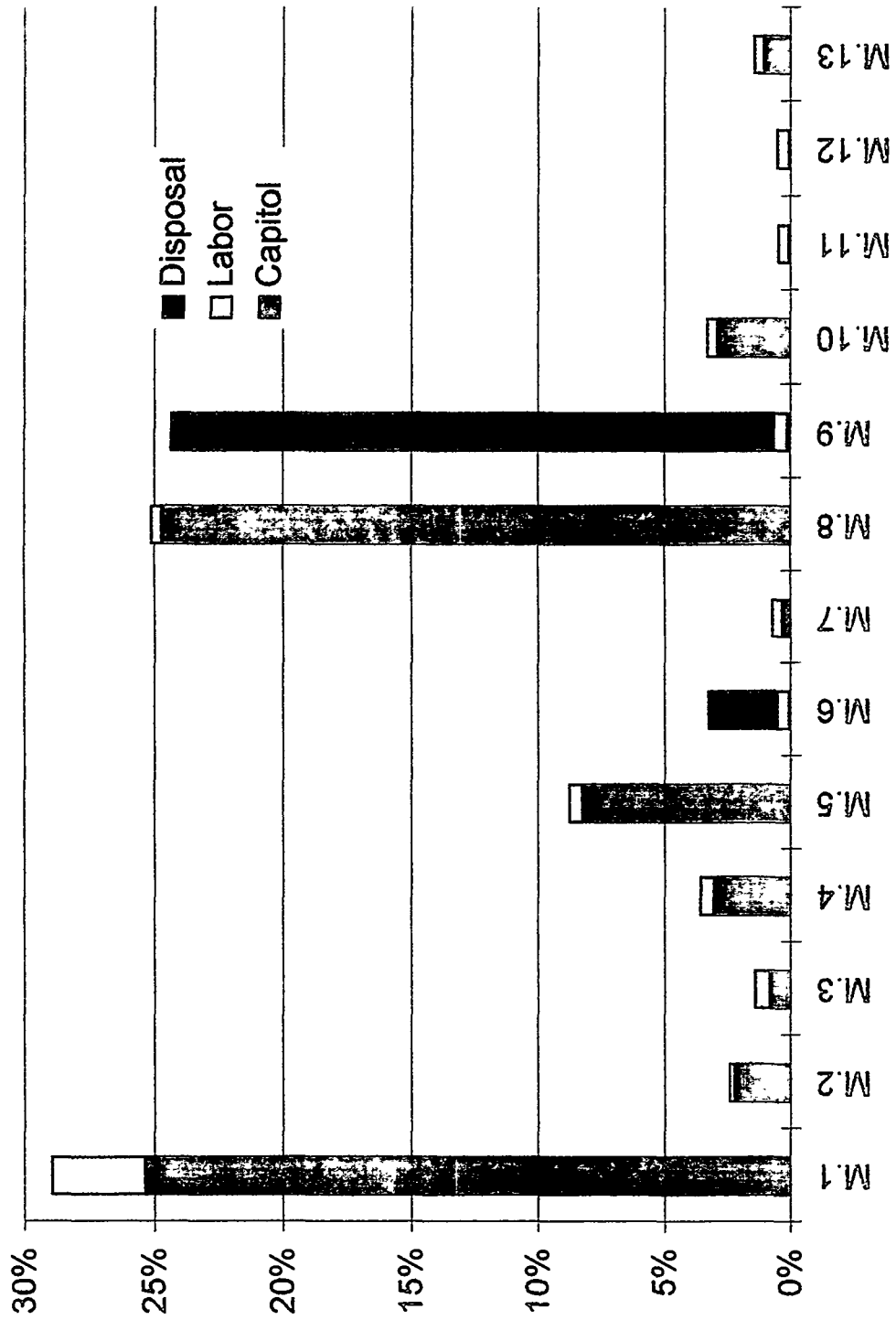

This page intentionally left blank.

Figure 10. Test Case II Costs (Percentage of Overall System Costs).

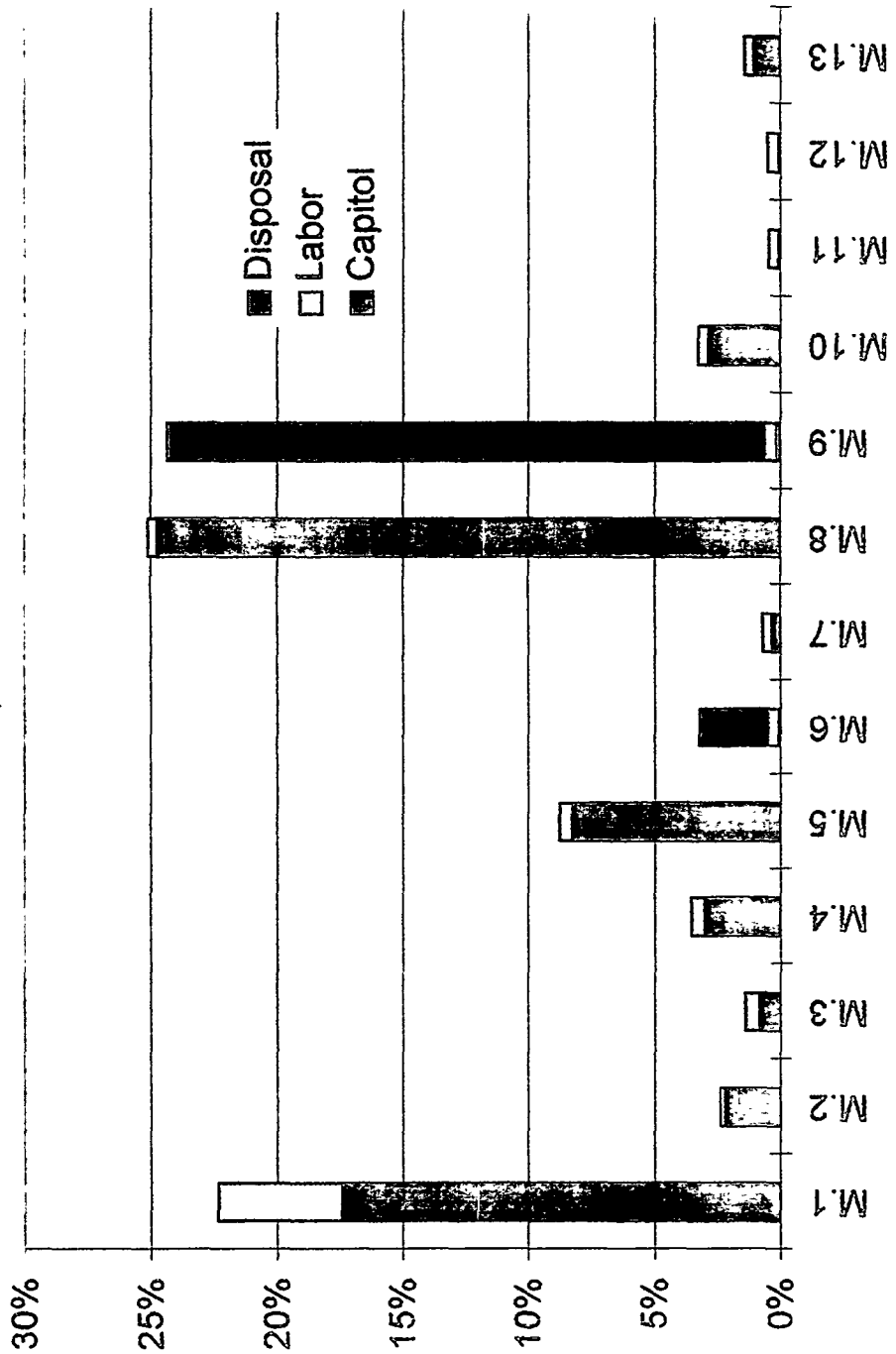

This page intentionally left blank.

4.0 SUMMARY AND CONCLUSIONS

The System Analysis Model provides the framework for evaluating the risk and cost of new technologies relative to a baseline remediation plan. The general approach incorporates new technologies into complete remediation systems to allow a disciplined assessment of overall system risk and cost.

The specific model reported here uses a structured methodology for estimating risks and costs of a baseline remediation plan for HLW tanks. The same methodology can be applied to alternative technologies to yield comparative costs and risks. A flowsheet and material balance for all stages of the Base Case from retrieval through disposal were first established. The risks and life-cycle costs of each stage were then defined. All risk element values and costs were summed to provide cumulative system risks and costs. Test Cases I and II were assessed by establishing a modified flowsheet and material balances for each test system. All test case risks and costs were assigned for the full system to arrive at a cumulative risk and cost which was compared against the Base Case.

The System Analysis Model provides a flexible, practical tool for decision-makers in the RWTRTFA. It is intended to bridge a gap between very complex (or nonexistent) system models developed by site remediation programs and the information needs for the RWTRTFA decision makers. The model and supporting software are designed to support online discussions of the relative added value of alternate remediation technologies. In that way, it should be a practical tool for building consensus among users, technologists, stakeholders, and final decision-makers.

Some constraints associated with this approach include the following.

- Cost and risk values are relative so there is the potential for misinterpretation as rigorous quantitative costs and risks. Figures shown here should not be considered absolute; however, the analyses are practical for comparing competing investments.
- Detailed resolution is not provided at the unit operation level. The model requires the addition or substitution of complete unit operations and/or system modules.
- Activities that do not directly impact cost or worker/public risk or that have impacts that cannot be quantified within the current system configuration are not specifically addressed (e.g., characterization methods).
- A limited set of exposure scenarios are currently included in the System Risk Analysis Model.

Some specific recommendations regarding the further development and use of the System Analysis Model are as follows.

1. If found to be feasible, incorporate physical injury, D&D, and routine waste disposal operational risks into the current composition of public/worker health and safety risks.

2. Incorporate a decision analysis framework that includes all important decision factors and associated weightings to be used in addition to the risk and cost impacts of technologies to facilitate technology screening and prioritization. Schedule, regulatory compliance, ecological impact, and socioeconomic impacts should be considered as an initial set of factors.
3. Perform and expand the uncertainty analyses to facilitate the evaluation and determination of critical model parameters.
4. Implement a more formal "method selection" process for the various risk assessment elements implemented in the model. The selection process would document functional objectives and criteria for the methods, and evaluate available analytical methods relative to those criteria and objectives. The end result would be documented bases for each of the methods implemented in the model. It is likely that this process would result in some changes to the current model risk methods.
5. Expand the number of model variables that the user can change online. This should improve the usefulness of the software.
6. Revise the Baseline System Characterization material balance to link the waste streams. The current mass balance does not provide for automatically maintaining a closed material balance. The user is currently allowed to change the masses of individual stream constituents but these changes are not automatically reflected downstream. The user is required to make all the appropriate changes to maintain a closed material balance. This process can be automated to force a closed material balance.
7. Evaluate whether nonprocess technologies such as characterization and safety can be incorporated into the current assessment methodology. Such technologies which currently can not be assessed include tank leak detection, in-tank waste characterization, and tank waste and structure surveillance (Light-Duty Utility Arm).

5.0 REFERENCES

National Environmental Policy Act of 1969, 42 USC 4321 et seq.

DISTRIBUTION

Number of copies

OFFSITE

2 U.S. Department of Energy-Headquarters
 12800 Middlebrook Road, Suite 400
 Germantown, MD 20874

 S. M. Gibson
 J. Mocknick

2 Enserch Environmental, Inc.
 1201 Jadwin, Suite 202
 Richland, WA 99352

 R. L. Treat
 B. B. Peters

1 Martin Marietta Energy Systems
 P. O. Box 2008
 Oak Ridge, TN 37831

 C. P. McGinnis

2 Science Applications International Corporation
 555 Quince Orchard Road, Suite 500
 Gaithersburg, MD 20878

 A. Livnat
 P. S. Szerszen

ONSITE

3 U.S. Department of Energy-
 Richland Operations Office

 D. A. Brown K8-50
 D. E. Trader K8-50
 Public Reading Room H2-53

2 MacTec

 V. Fitzpatrick K8-50
 D. J. Swanberg K8-50

20

Pacific Northwest Laboratory

W. F. Bonner	P7-41
P. M. Daling	K8-07
K. M. Fowler (2)	K8-19
B. M. Johnson	K1-78
G. H. McCabe	HARC
P. A. O'Mara	K8-24
R. K. Quinn	K1-73
D. A. Seaver	K8-27
S. C. Slate (4)	K1-19
T. G. Stewart	K1-73
W. G. Stillwell	K1-30
D. L. Streng	K3-54
M. J. Quadrel (3)	K1-73
Hanford Technical Files*	P8-55

21

Westinghouse Hanford Company

J. N. Appel	G3-21
W. B. Barton	L4-75
J. D. Bazinet	S4-53
K. D. Boomer	H5-49
J. M. Cruse	L5-63
R. C. Eschenbaum	N1-21
K. A. Gasper	R2-08
R. L. Gilchrist	L5-63
J. M. Henderson	S6-12
W. C. Miller	B1-58
R. J. Murkowski	R4-01
R. C. Roal	H5-27
D. G. Sutherland	L4-72
D. J. Washenfelder	L4-75
G. F. Williamson	R4-01
D. D. Wodrich	B1-59
Central Files	L8-04
Environmental Data Management	H4-22
File/LB*	L5-63
Information Release	A3-36
Administration (2)	

*Software not included.