

LA-UR-96-2950

CONF-9608123--11

Title:

THE RF SYSTEM FOR THE ACCELERATOR  
PRODUCTION OF TRITIUM (APT)  
LOW ENERGY DEMONSTRATION ACCELERATOR  
(LEDA) AT LOS ALAMOS

Author(s):

Michael T. Lynch  
Daniel E. Rees  
Paul J. Tallerico  
Amy H. Regan

Submitted to:

Linac Conference '96  
Geneva, Switzerland  
August 25-30, 1996

#### DISCLAIMER

This report was prepared as an account of work sponsored by an agency of the United States Government. Neither the United States Government nor any agency thereof, nor any of their employees, makes any warranty, express or implied, or assumes any legal liability or responsibility for the accuracy, completeness, or usefulness of any information, apparatus, product, or process disclosed, or represents that its use would not infringe privately owned rights. Reference herein to any specific commercial product, process, or service by trade name, trademark, manufacturer, or otherwise does not necessarily constitute or imply its endorsement, recommendation, or favoring by the United States Government or any agency thereof. The views and opinions of authors expressed herein do not necessarily state or reflect those of the United States Government or any agency thereof.

MASTER

**Los Alamos**  
NATIONAL LABORATORY

Los Alamos National Laboratory, an affirmative action/equal opportunity employer, is operated by the University of California for the U.S. Department of Energy under contract W-7405-ENG-36. By acceptance of this article, the publisher recognizes that the U.S. Government retains a nonexclusive, royalty-free license to publish or reproduce the published form of this contribution, or to allow others to do so, for U.S. Government purposes. The Los Alamos National Laboratory requests that the publisher identify this article as work performed under the auspices of the U.S. Department of Energy.

DISTRIBUTION OF THIS DOCUMENT IS UNLIMITED

Form No. 836 R5  
ST 2629 10/91

**DISCLAIMER**

**Portions of this document may be illegible  
in electronic image products. Images are  
produced from the best available original  
document.**

# The RF System for the Accelerator Production of Tritium (APT) Low Energy Demonstration Accelerator (LEDA) at Los Alamos

Michael T. Lynch, Daniel Rees, Paul Talerico, Amy Regan  
Accelerator Operations & Technology Division  
Los Alamos National Laboratory  
Los Alamos National Laboratory, Los Alamos, NM 87545 USA

## Abstract

To develop and demonstrate the crucial front end of the APT accelerator and some of the critical components for APT, Los Alamos is building a CW proton accelerator (LEDA) to provide 100-mA at up to 40-MeV. LEDA will be installed where the SDI-sponsored Ground Test Accelerator (GTA) was located. The first accelerating structure for LEDA is a 7-MeV RFQ operating at 350-MHz. This is then followed by several stages of a coupled-cavity Drift Tube Linac (CCDTL) operating at 700-MHz. The first stage of LEDA will go to 12-MeV. Higher energies, up to 40-MeV, come later in the program. Three 1.2-MW CW RF systems will be used to provide power to the RFQ. This paper describes the RF systems being assembled for LEDA, including the 350 and 700-MHz klystrons, the High Voltage Power Supplies, the transmitters, the RF transport, the window/coupler assemblies, and the controls. Some of the limitations imposed by the schedule and the building itself will be addressed.

## APT System Overview

The accelerator for APT is nominally configured at 1300 MeV, 100 mA, CW [1]. The accelerator layout uses an RFQ to accelerate to 7 MeV and a coupled-cavity, drift-tube linac (CCDTL) [2] to accelerate from 7 to 100 MeV. Above 100 MeV, a Coupled Cavity Linac (CCL) is the baseline structure, but consideration is also being given to a superconducting structure. In the room temperature configuration now planned, over 225 1-MW klystrons are required for the entire accelerator.

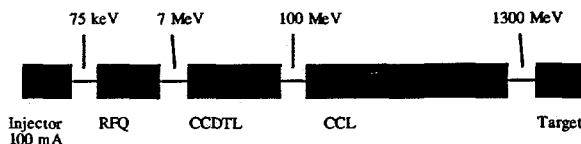

Fig. 1. APT accelerator schematic.

The front end portion of the accelerator is considered the key to success of the system, and therefore a demonstration accelerator (LEDA) is being developed at LANL.

One concept which is being investigated for use on APT is the supermodule. This is an assembly of accelerator modules which are resonantly coupled together. In theory, these supermodules could be extremely long, but we have chosen units which use 7 RF generators or less. In all supermodules, the design uses 1 more RF generator than necessary. This provides a type of on-line spare. Its operation allows any RF generator to fail, and the remaining generators can take over and provide the necessary power. This concept is one that we plan to test on LEDA.

## LEDA Overview

LEDA is being accomplished in several stages. Stage 1 includes the H- injector only and is in operation now. Stages

2 through 4 all have 100 mA of accelerated beam. Stage 2 adds the RFQ. Two klystrons are required for the RFQ, but it will be configured with 3 as a first test of the supermodule concept. Stage 3A adds the first section of CCDTL and requires 1 klystron. Stage 3B goes to 20 MeV and requires 2 klystrons. Stage 3A has an output energy of 10.7 MeV, and stage 3B has an output energy of 16.7 MeV. The building configuration as it now stands cannot power more than 5 klystrons total, so phase 3B does not allow testing of the supermodule (with the 'on-line' spare) on the CCDTL. Phase 4 adds significant modifications to the building and enough CCDTL to go to 40 MeV. In addition, a complete supermodule will be tested. The complete CCDTL from the output of the RFQ to 40 MeV will be resonantly coupled. Six klystrons will be needed to power it, and 7 will be installed. In the final phase of LEDA (phase 5) funneling will be tested, with a total 'funneled' current of 134 mA. A second leg will be added to 16.7 MeV, a funnel will be installed to combine the two beams at that point, and additional acceleration will take the complete beam to approximately 28 MeV. In phase 5, no additional klystrons will be used compared to that used for phase 4. In order to maximize the final energy, there will be no 'on-line' spares.

## RF System Architecture

A uniform RF system architecture is adopted for all APT RF systems. The RF system is made up of the klystron subsystem, the transmitter subsystem, the high voltage power supply subsystem, the transmission subsystem, and the cavity field control subsystem. A block diagram of the RF system is shown below in Fig. 2.

The **klystron subsystem** includes the klystron amplifier, its cooling, and the lead garage required for x-ray shielding.

The **transmitter subsystem** contains all support electronics for the RF system with the exception of the high voltage DC power supply subsystem. Included in the transmitter subsystem are the klystron focus coil supplies, the modulating anode voltage divider and pulser, the solid state preamplifier for the klystron, cooling interlocks, vacuum pump power supplies, computer interface electronics, crowbar trigger electronics, etc.

The **high voltage DC power supply subsystem** includes an SCR controller, a transformer rectifier, a crowbar and filter unit, and associated support electronics and computer interface. The high voltage power supply has a maximum output voltage of 95 kV and a maximum output current of 21 A for the 350 Mhz klystron generators and 17 A for the 700 MHz klystron generators.

The **transmission subsystem** contains all transmission line components required to provide the RF power generated by the klystron to the accelerating structure. This includes the waveguide from the klystron to the RF vacuum windows on the accelerating structures, including circulators, power splitters, waveguide switch, and RF loads. WR 2300 waveguide will be used for the 350 MHz RF system and WR 1500 waveguide for the 700 MHz RF

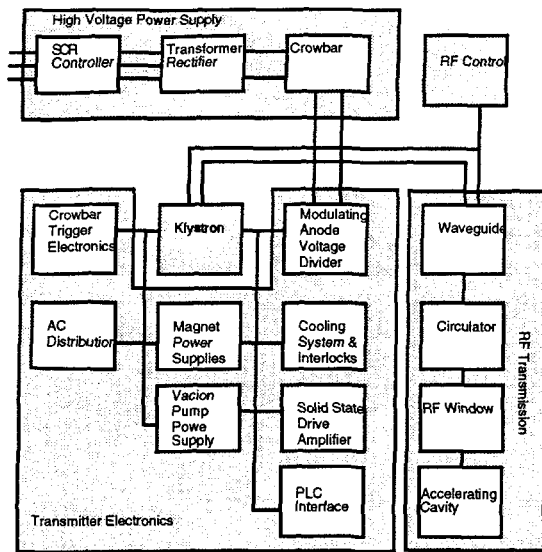

Fig. 2. RF system block diagram.

the power from a single klystron is divided into four equal parts using magic tees or hybrid waveguide power splitters. It is necessary to divide the power from the klystron to minimize the stress on the RF vacuum windows on the accelerating structures.

Each of the power splitters, the waveguide switch, and the circulator require an RF load. With the exception of the waveguide switch these loads only absorb significant power in fault conditions. Therefore, in order to minimize load cost we will use 200 kW CW loads protected by instrumented directional couplers. The philosophy is that unless the system is in a fault condition the load power will not exceed the 200 kW, and if the system is in a fault condition we would not want to operate and would bring the system off line for repair. The directional couplers will be used to verify the quality of the load match and the absolute power being absorbed by the load. This information will be used to rapidly disable the drive for the RF system if the power exceeds the loads capabilities or the load match degrades.

The cavity field control subsystem is described in detail in another paper at this conference (refer to "APT LLRF Control System Functionality and Architecture", by Regan and Rohlev). The control system contains the circuitry to ensure stable RF fields in the accelerating cavities, as well as some system interlock and interface circuitry. The low-level RF control system will perform a number of different functions: 1) Feedback and possibly feedforward techniques will be utilized to control the RF fields inside the accelerating cavities. 2) The resonance condition of each

cavity will be detected and control signals provided to the cooling water system used to maintain the cavities on resonance during normal operation. 3) A frequency agile drive signal will be provided to the klystron when the RF to the cavity has been off, as in the case of startup or failure recovery. In these situations the cavity resonance will be far from the fundamental operating frequency, so the frequency agile drive signal will allow faster recovery to the correct operating frequency. 4) The LLRF control system will develop the reference system for the entire accelerator. This work entails providing phase stable, coherent signals not only to every LLRF control system but also to other subsystems such as the Beam Diagnostics. The reference signal is both a time reference signal as well as the RF reference signal. 5) The LLRF control system will provide logic circuitry that can shut down the drive to high power amplifiers should a number of fault conditions exist, e.g., arcs, high reflected power.

### Key Issues

#### RF Vacuum windows

RF vacuum windows for CW accelerators are in service in the 200 - 300 kW range in the frequency spectrum of interest.

The window requirements for the RFQ are listed below in table 1. Four cases need to be evaluated to determine the most stressing case for the RF vacuum windows for the RFQ. The conditions include: whether or not beam is present and whether or not all klystrons are available or 1 klystron is off-line. The number of windows is based on using four windows per klystron (power divided four ways). The effective forward power per window (last column) is the forward power which would generate the same voltage as that of the combined forward and reflected powers.

A similar analysis has been performed on the CCL and CCDTL windows and their required power capacity is illustrated in table 2 for four windows per klystron. The worst case in both situations is beam on with 1 klystron off-line. However the effective forward power level is consistent with the demonstrated technology at accelerator facilities.

#### Super Module

The top level RF system design of a super module is illustrated below in Figure 3. The super module provides for on-line redundancy in the RF system. In the figure, only six of the seven klystrons illustrated are required to meet the RF power requirements of the accelerating structure. With an individual power supply and transmitter per klystron, the super module redundancy is also applicable to the high voltage system and klystron support electronics. Not shown is the complete splitting of the RF power. Only the first level of splitting is shown.

Table 1  
RFQ RF Window Requirement.

Condition	# Klystrons	VSWR:1	# Windows	P fwd kW	P ref kW	Pwr Cavity P incident kW	P fwd per window kW	Effct Fwd Pwr (kW)
No Beam	3	2	12	1485	165	1320	124	220
No Beam	2	1.33	8	1347	27	1320	168	219
Full Beam	3	1.2	12	2107	17	2090	176	209
Full Beam	2	1.25	8	2116	26	2090	265	327

Table 2

### CCL/CCDTL RF Window Requirement.

Condition	#	VSWR:1	#	P fwd	P ref	Pwr Cavity	P fwd	Effct
	Klystrons		Windows	kW	kW	P incident	per window	Fwd
						kW	kW	Pwr (kW)
No Beam	7	4	28	2125	765	1360	76	194
No Beam	6	2.67	24	1715	355	1360	71	151
Full Beam	7	1.25	28	5253	65	5188	188	232
Full Beam	6	1.2	24	5253	43	5188	218	259

During operation, and with no faults in any of the RF systems, all klystrons are operated at 6/7 of their maximum output power. When a fault is detected the RF systems for the super module are disabled and the waveguide switch is activated on the faulted unit. The waveguide switch serves two purposes. It connects the faulted unit to an RF load for evaluation, repair, and test. It also reflects a short circuit at the appropriate phase back to the accelerating structure so as not to perturb the accelerating fields. Once the failed system has been taken off-line the remaining systems are returned to service.

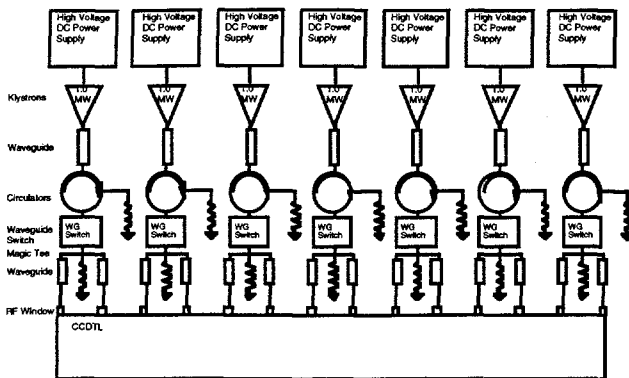

Fig. 3. Typical RF Super Module

The super module concept allows for rapid service restoration (5 minutes) in the event of an RF system fault. The failed component is then repaired off line and restored to service when convenient. It allows the RF system to meet its availability allocation of 95%. The additional cost for this configuration is seen in two ways. The number of installed klystrons is increased 17% (7 divided by 6), and the klystrons are not operating as efficiently as possible. Klystrons are designed to provide their maximum efficiency when operating saturated at a specific power level. We must operate below saturation to allow the accelerator field control circuits to operate properly. This reduces the operating efficiency from the maximum capable by the klystron. In addition, when 7 klystrons are operated to satisfy the needs of 6 they are operated below their nominal maximum output power. An additional efficiency penalty results. By variation of the klystron beam voltage and current the efficiency penalty can be minimized to a 1 - 2 % absolute reduction in efficiency. The adjustment of the klystrons cathode voltage has additional impacts to the high voltage power supply in terms of increased ripple, line harmonics, and reduced power factor as it is operated below its nominal design point.

While there is an operational efficiency penalty that results from operating a klystron below its maximum power there is also a corresponding increase in klystron operating life. Experience at accelerator facilities world wide indicate that high average power klystrons operate more reliably if in their typical service environment they are utilized below their

maximum capacity. Also, experience on LAMPF indicates that if the klystrons are typically operated under ratings the operating life of the klystron can be dramatically increased. Several klystrons at LAMPF have over 100,000 hours of operating life. The super module architecture also allows for the repair and test of klystrons and their associated electronics in situ and validation of performance before the RF system is returned to service. This greatly simplifies maintenance activities and minimizes mean time to repair.

### Capital and Operating Cost

In such a large system (>200 MW of CW RF power), cost is an important issue. While klystrons are the baseline choice for the RF generator, we are considering other types of sources. These include advanced klystrons of several varieties (depressed collector, high efficiency designs using multiple second harmonic cavities, multi-beam klystrons), and inductive output tube types which operate class B and consequently have very high 'operating' efficiency. The high operating efficiency is due to the slow rolloff in efficiency over the upper 25% of output power range (Figure 4). Another area of investigation is the HVPS. We are investigating the use of both 6-pulse and 12-pulse SCR-type supplies, and we are looking into solid state switching power supply technology, based on IGBT's, to achieve enhanced power factor and efficiency.

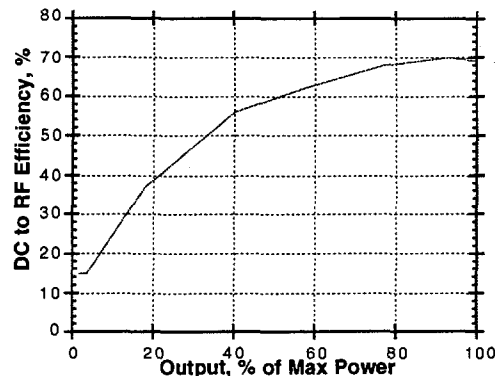

Fig. 4. Inductive Output Tube (IOT), Efficiency vs. Output Power

### References

- [1] G. Lawrence, et al., "Conventional and Superconducting RF Linac Designs for the APT Project," these proceedings.
- [2] J. H. Billen, F. L. Krawczyk, R. L. Wood, and L. M. Young, "A New RF Structure for Intermediate-Velocity Particles," Proceedings of the 1994 International Linac Conference, Vol. 1, p. 341 (August 21-26, 1994).