



ENGINEERING INNOVATIONS ON THE SSC DTL ACCELERATOR

J.P. Rymer, J.M. Potter, J. Givens, B. Campbell†, L. Hansborough*

AccSys Technology, Inc.

1177-A Quarry Lane, Pleasanton, California 94566, U.S.A.

Abstract

The engineering design of the drift-tube linac (DTL) tanks for the Superconducting Super Collider (SSC) linac incorporates numerous innovative features, resulting in a reliable, cost-effective accelerator structure suitable for commercial production. The tank structure includes two integral strongbacks that provide stable mounting surfaces for the drift tubes and ion pumps and add mechanical stiffness. Drift tubes are mounted using AccSys' patented semi-hard socket technique, which includes separate metal seals for rf and vacuum. The socket allows repeatable adjustment of drift-tube location, thus allowing the tank to be fabricated to realistic tolerances. Transverse alignment of the drift tubes will be accomplished using a pulsed taut-wire technique to align the magnetic centers of the permanent magnet quadrupoles. This technique has been improved to allow drift-tube alignment throughout a 6 m long tank. For maximum reliability, the individual drift tubes include water-cooling channels that have no water-to-vacuum joints. Each tank will be driven through a waveguide iris coupler that can be adjusted to optimize the coupling.

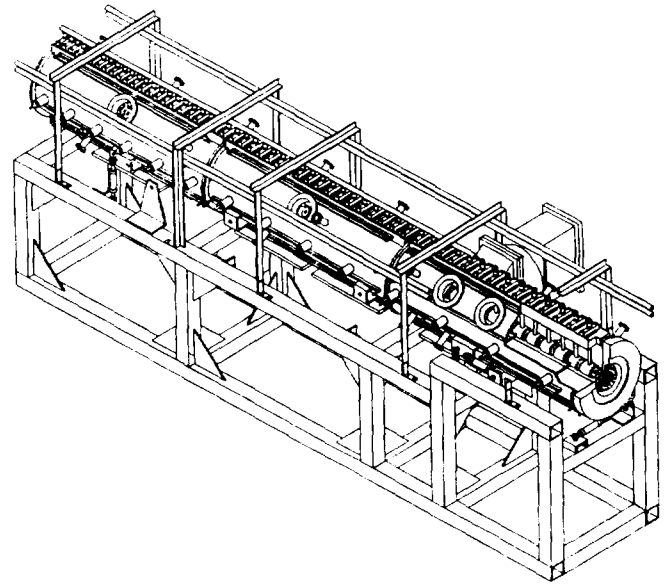

Fig. 1 Tank 1 on its frame.

Introduction

The SSC DTL accelerates a 25 mA proton beam from 2.5 MeV to 70 MeV in four independent tanks. The DTL features post-stabilizers and waveguide rf power feeds. Each tank operates at 427.617 MHz, with a peak power of approximately 2 MW at 0.1% duty factor. The detailed physics design is described in reference 1. The basic physical parameters of the DTL are listed in Table 1. Tank 1, mounted on its support frame, is depicted in Fig. 1. This paper describes engineering innovations and features that are incorporated in the accelerating structures of the SSC DTL.

TABLE 1
DTL Physical Parameters

Tank inside length	4.50, 5.96, 6.06, 6.26 m
Tank inside diameter	0.425 m
Clear aperture	0.016 m
Post-couplers per tank	27, 38, 28, 24
Drift tubes per tank	57, 41, 31, 27
PMQ gradient	132.7 T/m
PMQ length	0.035 m
Magnet lattice	FODO

Tank and Drift-Tube Construction

Each DTL tank is constructed of three or four sections bolted together at flanged joints to form the full length. Fabricating the tank in short sections allows precision machining and copper-plating vertically in standard tanks, using conventional equipment. A copper-plated inconel C-seal makes both the vacuum and rf seal at each section joint. Rails that act as strongbacks run the full length of each tank section, both on top and bottom. These provide a stable mounting place for the drift tubes and for the ion pumps and add mechanical stiffness to the tank. Low-carbon steel is used for the tank because of its desirable thermal conductivity and expansion properties. After fabrication and machining, the tank sections are copper-plated for high rf conductivity and low outgassing rate.

On each tank the top strongback has precision-machined mounting areas for each drift tube. The drift tubes themselves are mounted with AccSys' patented semi-hard socket, which allows fine adjustment of each drift-tube position by selecting appropriate shims, yet provides repeatable location of the drift tube. A copper-plated inconel C-seal makes good rf contact between the stem and the tank over the full vertical-adjustment range. A metal spring-energized seal provides a long-lifetime vacuum seal to the drift-tube stem and could be replaced, if necessary, without removing the drift tube.

†Superconducting Super Collider Laboratory, Dallas, Texas.

*Los Alamos National Laboratory, Los Alamos, N.M.

Drift-tube bodies and noses are of copper to minimize thermal gradients, while the stems are of copper-plated stainless steel to maximize vibrational stiffness. Temperature-controlled water flows through a seamless, formed tubing brazed into the drift-tube body. Maximum protection against water leaks is assured by the absence of any water-to-vacuum joints. Permanent magnet quadrupoles are mounted in the drift-tube bodies using tolerance rings to provide stored energy for long-term stability. Drift-tube noses are attached by electron-beam welding using appropriate fixturing to shield the electron beam from the quadrupole field. In the finished drift tube, the magnet is located in a sealed cavity isolated from the tank vacuum. The magnet cavity is connected to a port at the top of the stem and could be connected, if necessary, to an external soft-vacuum system. A cut-away view of a typical drift tube is illustrated in Fig. 2.

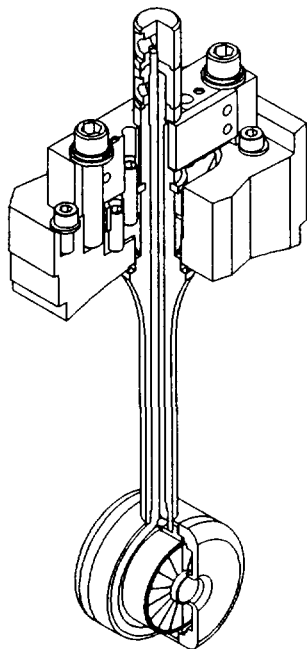

Fig. 2 Drift tube and mounting.

Every tank is mounted on its own support frame by six struts of adjustable length with spherical bearing ends. This provides a stable, minimally constrained system that cannot apply undesired forces or torques to the DTL tank, yet can precisely adjust the tank position in three dimensions for alignment to the beam line. The three vertical struts are located to minimize static vertical deflection, while the longitudinal strut is fixed to allow thermal expansion to occur equally about the midpoint of the tank.

Iris Coupling

Radio-frequency power to each DTL tank is coupled from WR-1800 waveguide through a coupling slot, or iris, cut directly in the wall of the DTL. A waveguide vacuum window, placed approximately one-half guide wavelength

from the iris, isolates the DTL vacuum from the gas-filled waveguide. The DTL cross section, Fig. 3, shows the iris and vacuum window.

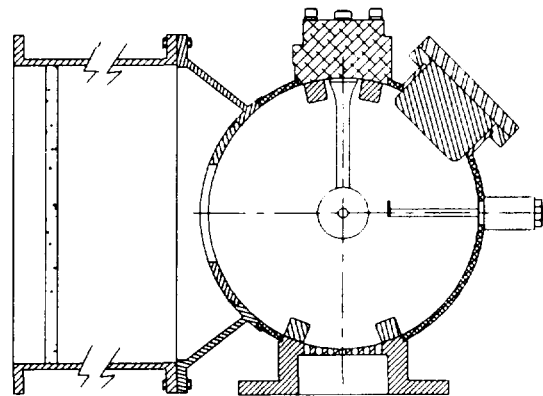

Fig. 3 Simplified DTL cross section.

There are several features of iris coupling that make it more desirable than loop coupling for high-power accelerator systems with waveguide feed from the rf power source. Iris coupling is simpler, in principle, because it eliminates the need for a waveguide to coax transition. Waveguide has higher peak and average power-handling capability than coax. Multipactoring problems are reduced because of the larger spacing between opposing surfaces and the higher pumping speed between the vacuum window and the DTL. This simplification and improved performance require overcoming two engineering-design obstacles.

The vacuum window must be placed in the WR-1800 waveguide, making it much larger than a vacuum window for coax line. Two commercial vendors have offered solutions to the vacuum window problem with window designs that feature broad tuning and low stored energy, ensuring good performance with a high-Q resonant load.

It must be possible to adjust the iris size after plating without exposing any steel to the rf fields. AccSys has solved the iris-cutting problem by brazing a section of copper plate into the tank wall prior to plating the tank. The plate is curved to match the tank-wall radius. An adapter flange from the tank to the WR-1800-sized vacuum window assembly is welded to the tank wall beyond the extent of the copper plate. Thus, the braze joint is entirely within the vacuum, and the joint needs only to have good electrical conductivity and does not need to be vacuum-tight. However, a solidly filled braze joint is desirable to avoid trapping plating solution. The iris size is determined approximately by scaling from measurements taken on the AccSys scale model DTL. The initial iris size is deliberately cut small to ensure that the desired coupling factor (VSWR=1.6:1, over-coupled) can be achieved. The iris will be enlarged by machining until the desired coupling factor is reached.

Taut-Wire Alignment

The taut-wire quadrupole alignment scheme developed at Los Alamos National Laboratory will be used to locate the magnetic centers of the DTL permanent magnet quadrupoles. The AccSys drift-tube socket makes it easy to correct the drift-tube positions by changing the shims in accordance with position deviation information obtained by this method.

The length of the SSC DTL tanks (~6 m) requires improvements to the basic scheme described in reference 2. The sag of the taut wire must be less than 2 to 3 mm in the 16 mm diameter beam hole to ensure accurate results in the vertical direction over the length of a tank. Sag is minimized by using lightweight, beryllium-copper wire at high tension. The penalty for reduced sag is increased wave velocity and decreased deflection of the wire. The high wave velocity is accommodated by using a high-speed (200 kilosamples/sec) data acquisition board and a short high-current impulse. The short pulse and high wire tension result in reduced deflection of the wire for a given magnet offset. The decreased deflection is compensated for by improving the signal-to-noise ratio of the wire-position measuring scheme.

A high signal-to-noise ratio is obtained by directly exciting the wire with a 200 mW high-frequency signal in the 200 to 400 MHz range to increase the signal size and by enclosing the wire in a shield that reduces electrical noise pickup and protects the wire from air currents. The detector is a superheterodyne receiver with a linear detector similar to the LAMPF beam position monitor detector.[3] The noise level observed in a test setup was less than 12 μm without averaging multiple runs.

Drift-Tube Tolerances

The geometry of the drift tubes affects the DTL performance by changing the internal cell field distribution, the cell-to-cell field distribution, the gap center location, and the overall tank frequency. The field distribution is significant only insofar as the on-axis integrated fields deviate from the design distribution. However, the post-stabilizers provide a means by which the field distribution can be stabilized against the effects of cell frequency errors. The post-stabilizer tabs provide an asymmetry adjustment that can be used to correct for deviations of the stabilized field distribution. Experience has shown that field distribution errors can be made adequately small for drift-tube dimensional errors that are much larger than are otherwise acceptable.

Errors in the length of the drift tubes can combine to produce shifts in the distance between gap centers. This effectively produces a phase error between the beam bunch and the rf fields. The drift-tube length errors that produce a worst-case gap-to-gap phase error of 0.5° vary from 0.07 mm MeV end of the DTL to 0.35 mm at the 70 MeV end.

On the other hand, errors in the dimensions of the drift tubes also contribute to the tank frequency error. A tank

frequency error of approximately 1.1 MHz has been allocated to drift-tube dimensional errors. The basic dimensions include the drift-tube face angle, the drift-tube radius, the drift-tube corner radius, the beam-hole radius, the drift-tube nose radius, and the drift-tube stem radius, as well as the drift-tube length. Of these, the face angle, the corner radius, and the length are the most critical. For a practical allocation of dimensional errors, the length tolerance varies from 0.03 mm to 0.13 mm for beam energies of 2.5 MeV to 70 MeV. Since this is a tighter tolerance than required for maintaining the allowable gap-to-gap phase error, allowable frequency error dominates the tolerancing of the drift-tube dimensions. The dimensional tolerances are tightest at the low-energy end of the DTL, where the drift-tube spacing is closest.

Temperature Control

The frequency of each DTL tank is set by four tuning bars running the length of the tank for coarse tuning and three or four tuning slugs (one for each tank section) for fine tuning. These tuning elements compensate for frequency deviations due to fabrication tolerances to bring the tank to the design frequency at the nominal operating temperature. The resonant frequency of each tank is maintained over a ± 15 kHz tuning range by controlling the temperature of the water flowing through passages in the tank walls and in the drift tubes. Water is circulated in a closed-loop system that is thermally coupled to the house water system by means of a heat exchanger. Since the nominal operating temperature is 43.5°C , no mechanical refrigeration is included; enough cooling is provided by the heat exchanger to the house water. An electric heater is included so that operating temperature can be maintained under varying conditions and so that the tank can be warmed up from a cold start. Active control of the electric heater provides frequency control for the tank. The control signal is based on the temperature of water exiting from the drift tubes, since their temperature substantially determines the tank frequency. Controlling on the drift-tube water temperature also increases the tuning rate that can be achieved.

Acknowledgements

The authors wish to acknowledge useful advice from J. Billen, E. Bush, E. Knapp, D. Lishka, and P. Morton. They would also like to thank D. Haas, R. Ma, M. Patterson, and C. Stokes for their contributions to the design.

References

- [1] D. Raparia *et al.*, "SSC Drift-Tube Linac Design", these proceedings.
- [2] C. Fortgang *et al.*, "Pulsed Taut-Wire Alignment of Multiple Permanent Magnet Quadrupoles", Proc. 1990 LINAC Conf. LA-12004-C, Los Alamos report, 426 (1990).
- [3] J.M. Potter, private communication.