

**ACCELERATION, ION FOCUSING (IFR) AND TRANSPORT EXPERIMENTS WITH THE RECIRCULATING LINEAR ACCELERATOR (RLA)\***

M. G. Mazarakis, D. L. Smith, J. W. Poukey, L. F. Bennett, J. S. Wagner, W. R. Olson, M. George, B. N. Turman, K. R. Prestwich, K. W. Struve†  
 Sandia National Laboratories, Albuquerque, NM 87185

**Abstract**

The focusing and transport of intense relativistic electron beams in the Sandia Laboratories Recirculating Linear Accelerator (RLA) is accomplished with the aid of an ion focusing channel (IFR)<sup>1</sup>. We report here experiments evaluating the beam generation in the injector and its subsequent acceleration and transport through the first post accelerating cavity. Two injectors and one type of post accelerating cavity were studied. Beams of 6-20 kA current were injected and successfully transported and accelerated through the cavity. The transport efficiencies were 90%-100%, and the beam Gaussian profile (4 MeV injector) and radius (5mm) remained the same through acceleration. In the following sections we describe the RLA, present the experimental results and compare them with numerical simulations.

**Introduction**

In these experiments we studied the beam transport only through the first straight section of the RLA.<sup>1</sup> Two injectors were utilized: a low-energy 1.3-MV Isolated Blumlein (IB) injector<sup>2</sup> and a 4-MV four-stage inductive voltage adder injector. For both injectors an apertured, non-immersed, ion-focused foilless diode was selected among various options studied. It is the simplest and easiest to operate and can be adjusted to provide variable beam impedance loads to the injector. In the next two sections we report first the transport experiments with the lower energy 1.3-MV, 6-kA injector followed by the evaluation and transport of the beam produced by the new 4-MV, 20-kA injector.

**EXPERIMENTAL SETUP  
 INJECTOR AND ET-2**

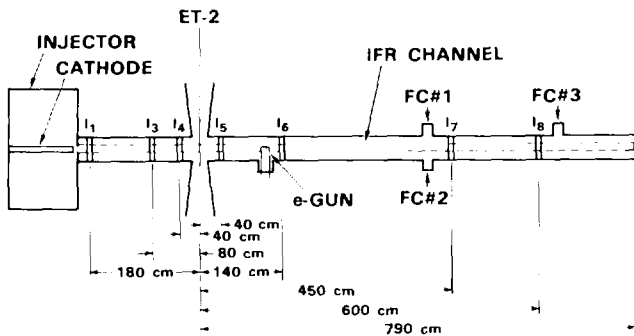

Fig. 1 Experimental set-up. Low energy 1.3MV injector.

**Transport Experiments with the 1.3-MV Injector**

The main goal of these earlier experiments was to evaluate the beam transport efficiency through a 10 m long IFR channel both with and without post acceleration. Figure 1 shows the actual experimental set-up. The main diagnostics utilized to measure the current were Rogowski coils. Figure 2 shows the beam current waveforms at various locations along the beam line downstream from the injector.

**FIRE ONLY INJECTOR  
 TRANSPORT EFFICIENCY 83%**

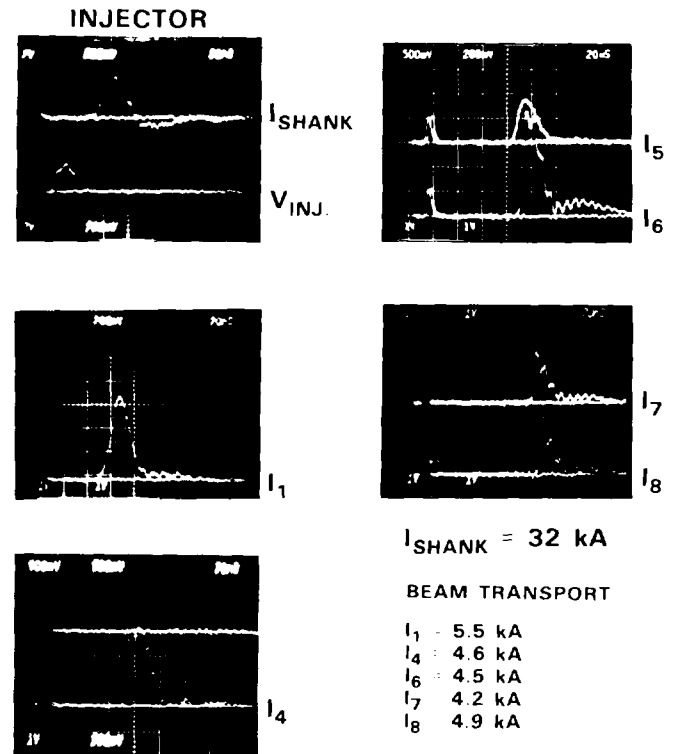

Fig. 2 Samples of the current wave forms. Only the injector was pulsed.

The numerical subscript by the current symbol ( $I, i=1...9$ ) corresponds to the location in the beam line of each Rogowski coil (Fig. 1). The post accelerating cavity was not energized in these shots. The peak current transport efficiency was 83%; however, the total charge transport efficiency was lower (60%) due to beam erosion. Figure 3 gives similar samples of current waveforms with the postacceleration gap energized to provide a synchronous accelerating pulse with the injector. The total kinetic energy of the beam downstream from the injector increased to 2MeV, providing an improved peak current transport (90%) efficiency and a reduction of the erosion of the beam

front. In order to further reduce beam erosion, increase current and lengthen pulse width, we replaced the 1.3MV injector with the 4-MV, 20-kA injector.

### FIRE INJECTOR AND ET-2 IN SYNCH. TRANSPORT EFFICIENCY 90%

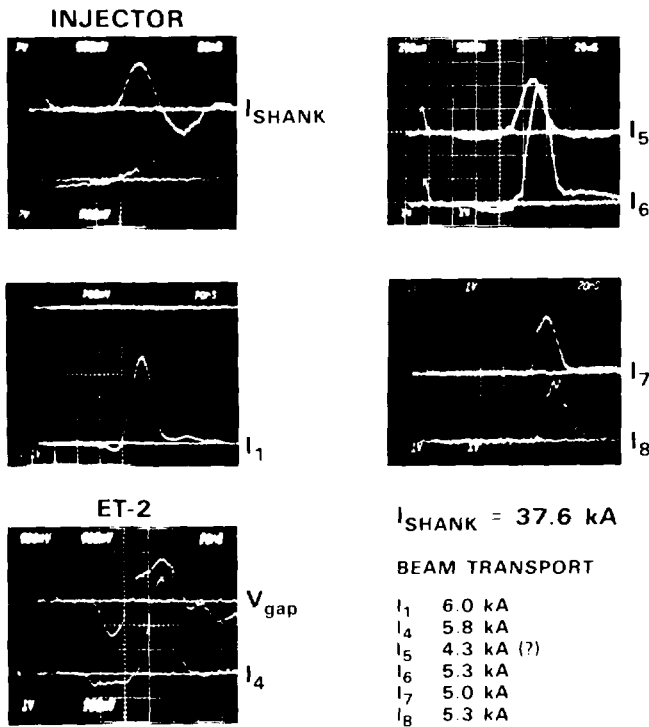

Fig. 3 Current wave forms with injector and ET-2 cavity pulsed in synchronism.

### 4-MeV Injector Beam Evaluation and Transport Experiments

Figure 4 shows the experimental set-up with the new 4-cavity inductively isolated voltage adder injector. In the first set of experiments the beam line is interrupted just before the ET-2 cavity<sup>3</sup> in order to install an x-ray pin-hole camera. The beam propagates 130 cm through the IFR channel before striking a 0.12 mm tantalum x-ray converter. Figure 5 shows an x-ray photograph of the beam on the tantalum target together with the scan of the light intensity along one diameter of the digitized version of the same photograph. The scan is least square fitted to a Gaussian profile. The beam has a Gaussian current density distribution with a 5 mm radius. In the second set of experiments the beam was transported further downstream from the injector and accelerated by the ET-2 cavity. The beam profile and radius were evaluated from the photographs obtained by the x-ray pin-hole camera (Fig. 7). The total beam propagation length from the injector diode to the x-ray converter was 4.4 m. Figure 6 presents typical voltage and current scope traces for the shot #253. The

### EXPERIMENTS WITH THE NEW 4-MV INJECTOR AND ET-2 CAVITY

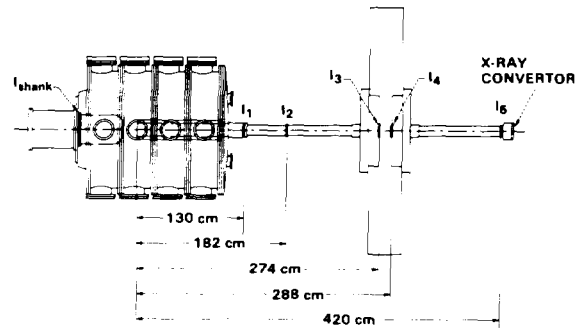

Fig. 4 Experimental set-up with the 4-MV injector. A re-entrant geometry is selected for the injector.

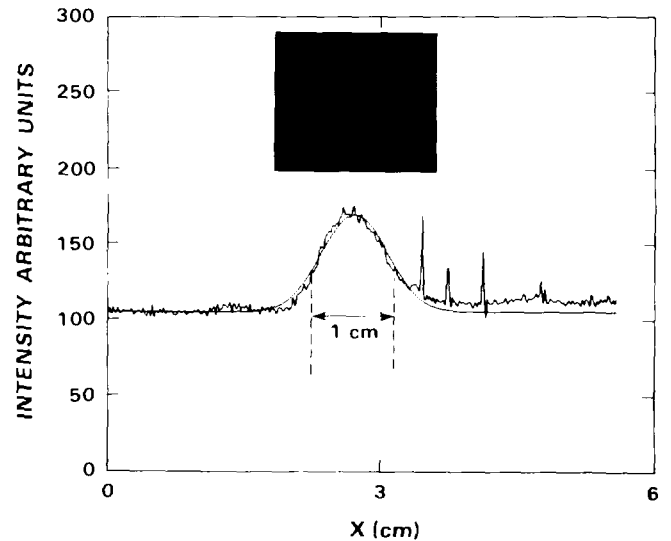

Fig. 5 Beam profile 130 cm downstream from injector diode.

### INJECTOR VOLTAGE AND BEAM CURRENT

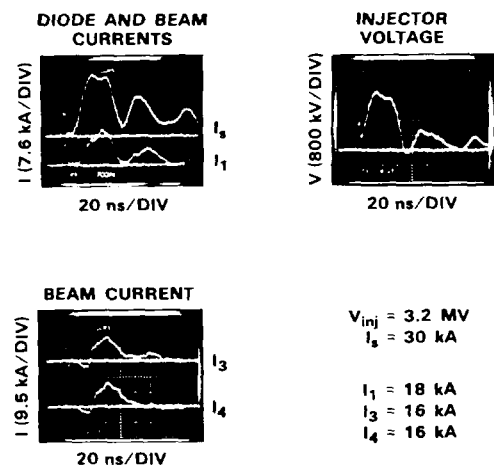

Fig. 6 Injector and beam current traces for a typical shot.

beam current profile and amplitudes before and after acceleration (Rogowski monitors #3 and #4) are the same and equal to 16 kA. Figure 7 shows a pin-hole x-ray photograph of the beam 4.4 m downstream from the injector together with a scan of the beam density profile along a diameter of the same photograph. A comparison of figures 4 and 7 indicates that the beam has conserved its Gaussian profile and radius of 5 mm throughout transport and post acceleration by the ET-2 gap. These results suggest that the beam comes into equilibrium with the IFR channel in the first meter of propagation and continues in equilibrium further downstream through the accelerating gap.

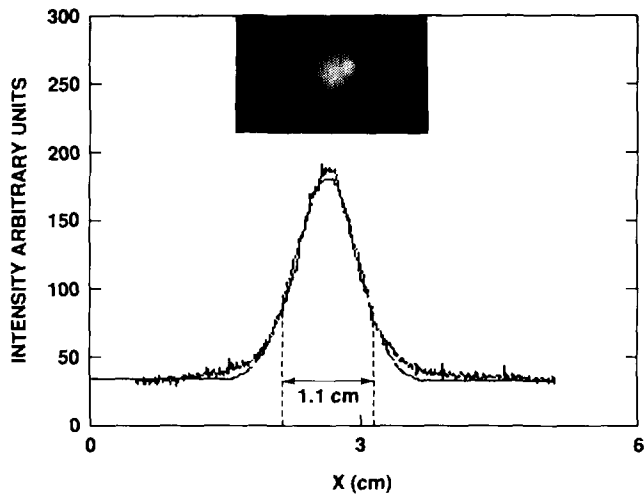

Fig. 7 Beam profile 440 cm downstream from the injector.

## Conclusions

The low energy (1.3-MV) experiments demonstrated successful transport and post-acceleration of 6kA beams. The first decelerating prepulse of the ET-2 cavity did not appear to disturb the IFR channel integrity and increased the transport efficiency to 90%. The 4-MV RLA injector was successfully put into operation and produced an electron beam which was transported 4.4 m downstream from the injector and accelerated through the ET-2 cavity. The x-ray pin-hole photographs of the beam on the tantalum converter before and after post acceleration through the ET-2 gap are the same and reveal a Gaussian density profile of 5 mm radius. A maximum beam current of 16 kA was transported and successfully accelerated through the ET-2 cavity with 100% efficiency.

## REFERENCES

- \* Supported by Navy SPAWAR under Space Task No. 145-SNL-1-8-1, by U. S. DOE Contract DE-AC04-76DP00789, and DARPA Order No. 7877
- † Mission Research Corporation, Albuquerque, NM
- 1 M. G. Mazarakis, et al., proc. 1990 Linear Acc. Conf., Albuquerque, NM, Los Alamos-Report-LA-12004-C, p.605 (1990)
- 2 W. K. Tucker, et al., Proc. IEEE Part. Acc. Conf., Washington, D.C. (1987) IEEE No. 87CHZ387, p.257
- 3 D. Eccleshall, et al., IEEE Trans. On Nucl. Sci. **28** 3386 (1981)