

320



XA9949125



Nuclear Power Plant Dukovany
Training Centre

BASIC SCHEME OF PERSONNEL TRAINING SYSTEM

F. Rerucha and J. Odehnal,
Czech Republic

Dukovany 1997

ČEZ-EDU and contractors personnel training system

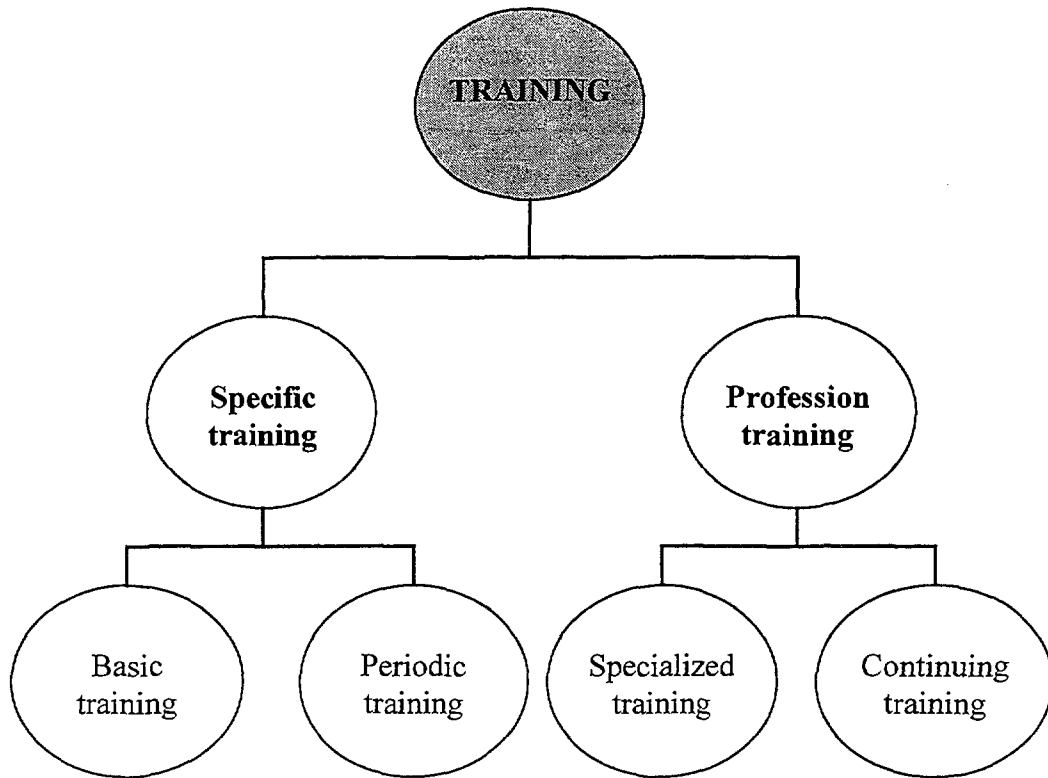

Incorporation of Basic training in the Training system

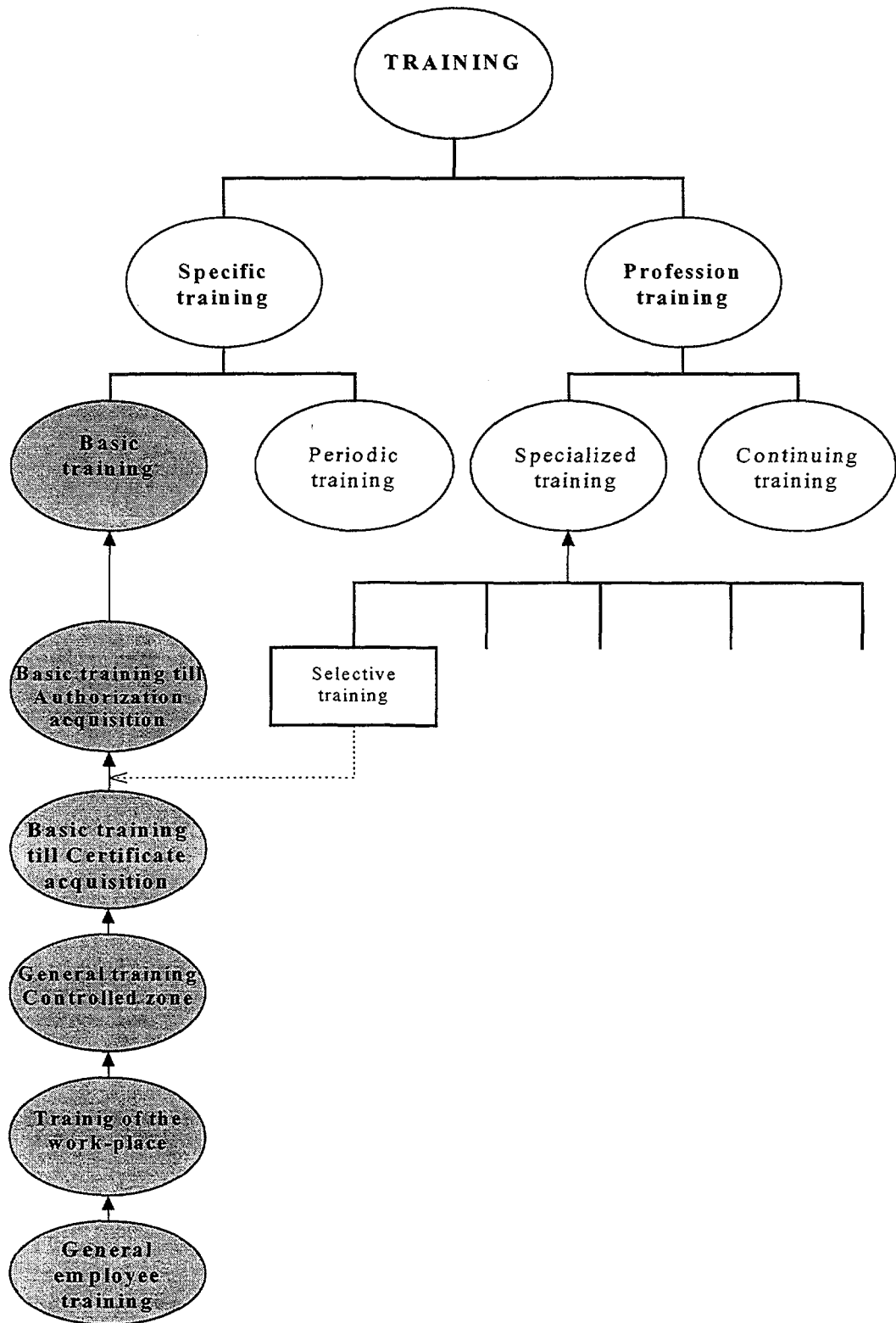

Incorporation of Periodic training in the Training system

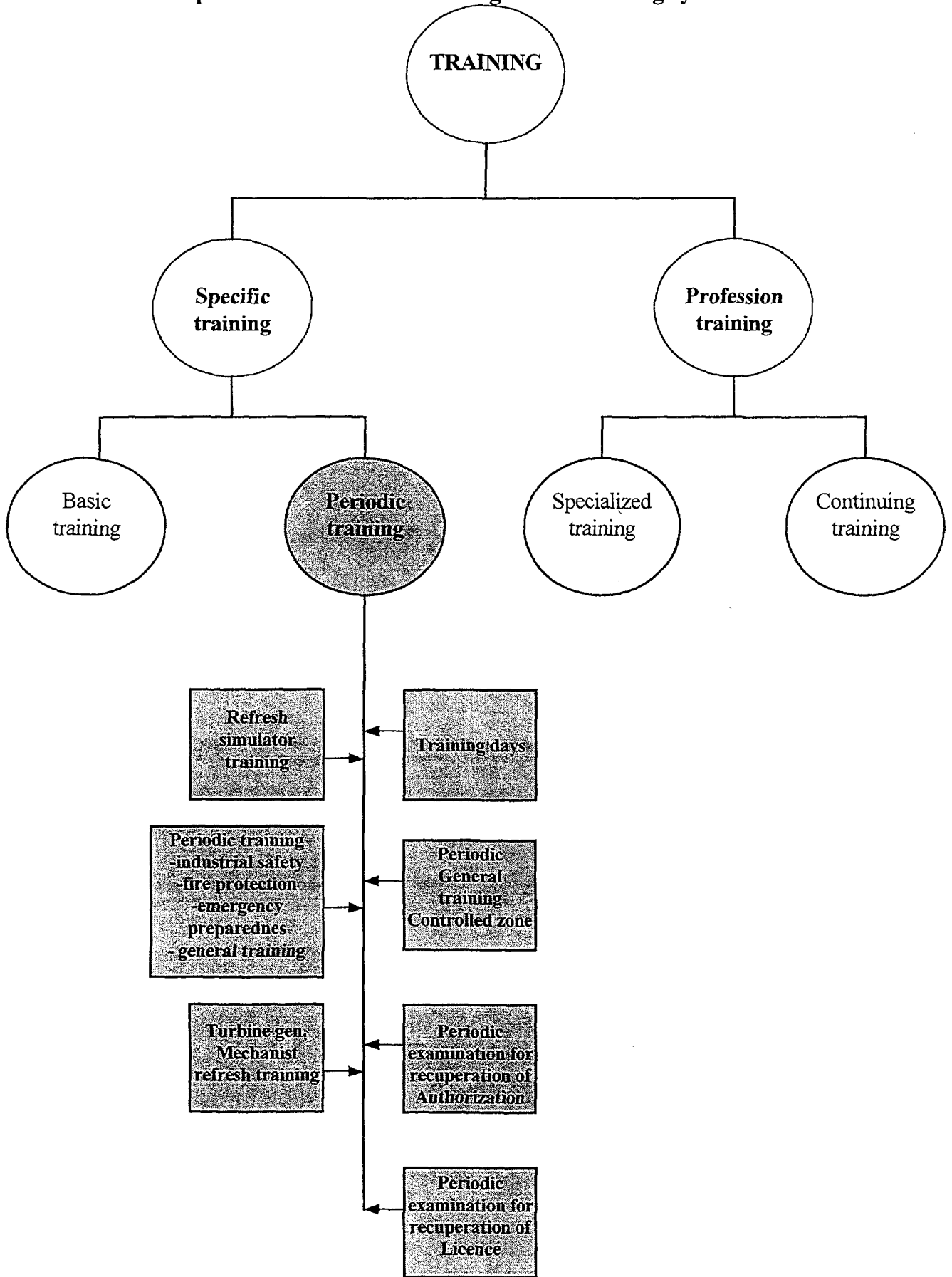

Incorporation of Profession training in the Training system

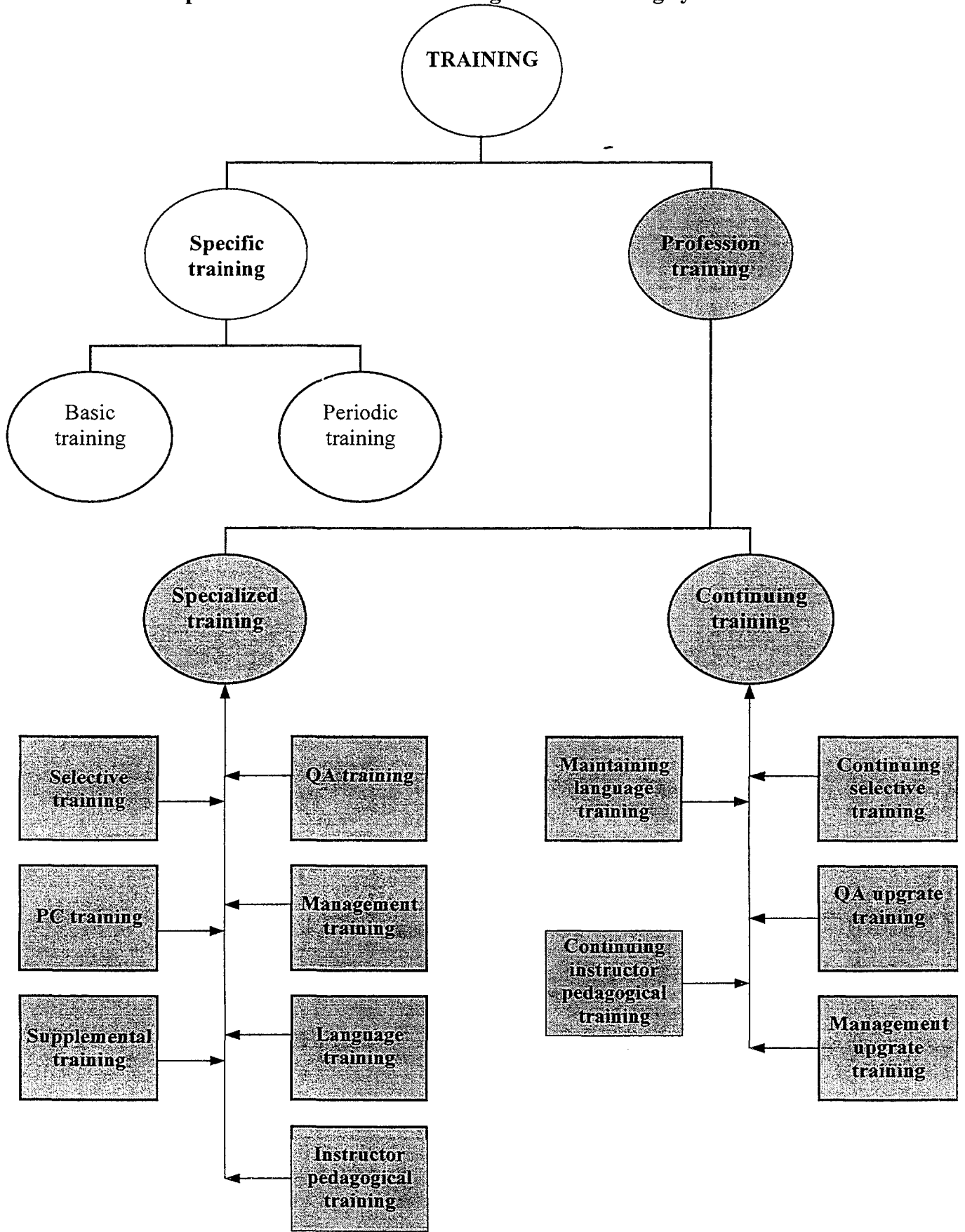

CATEGORY ALPHA AND GAMMA

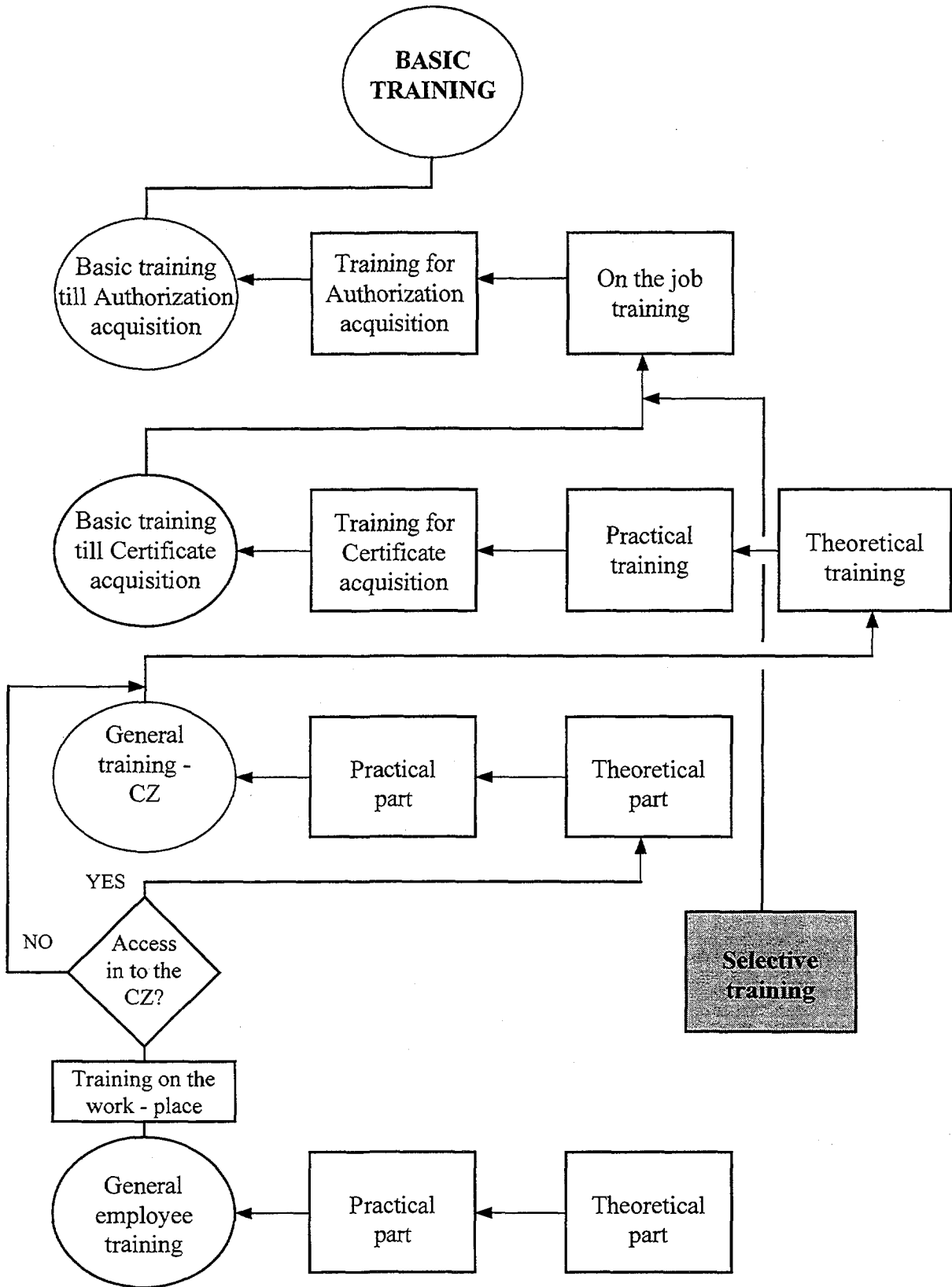

CATEGORY BETA

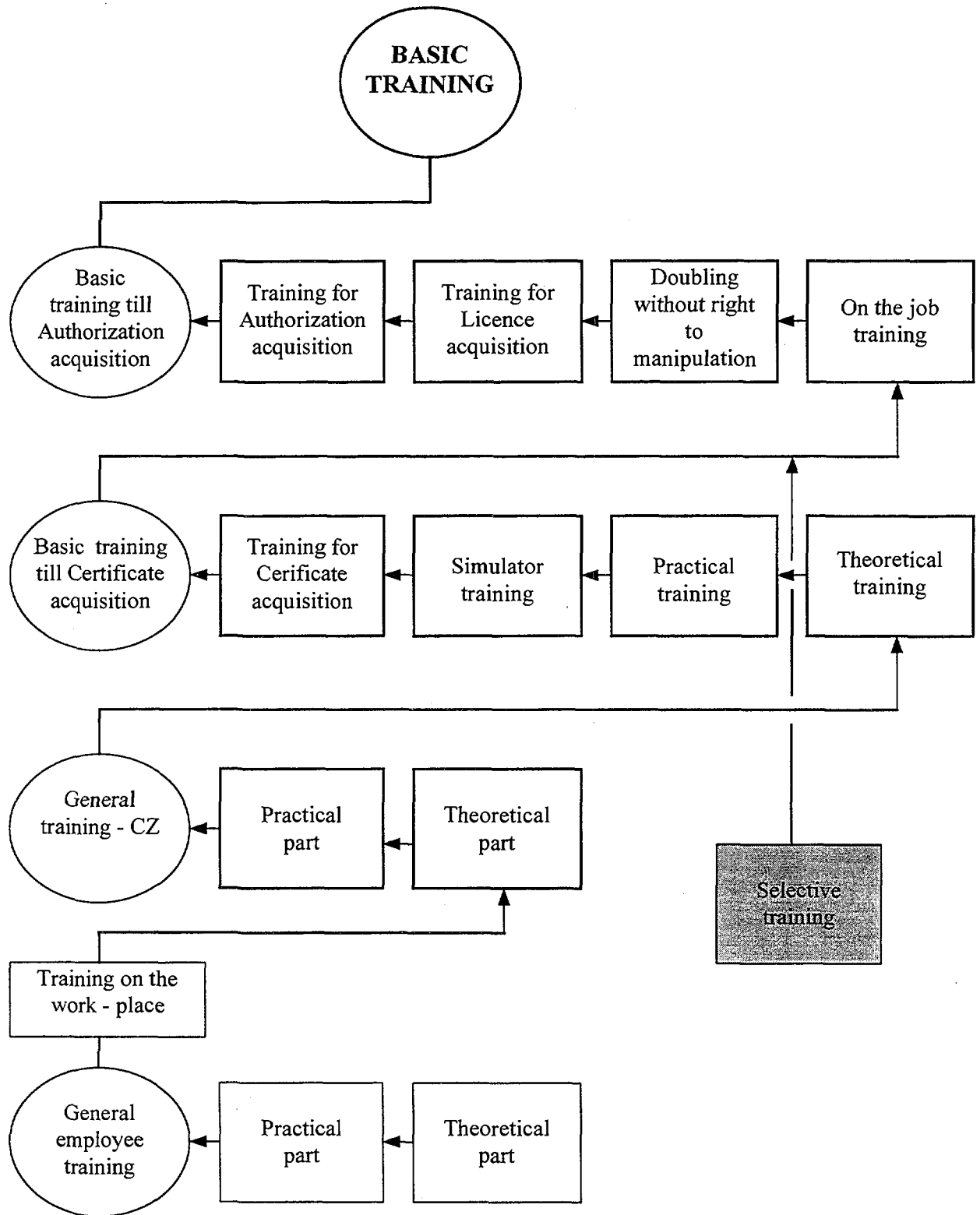

CATEGORY DELTA

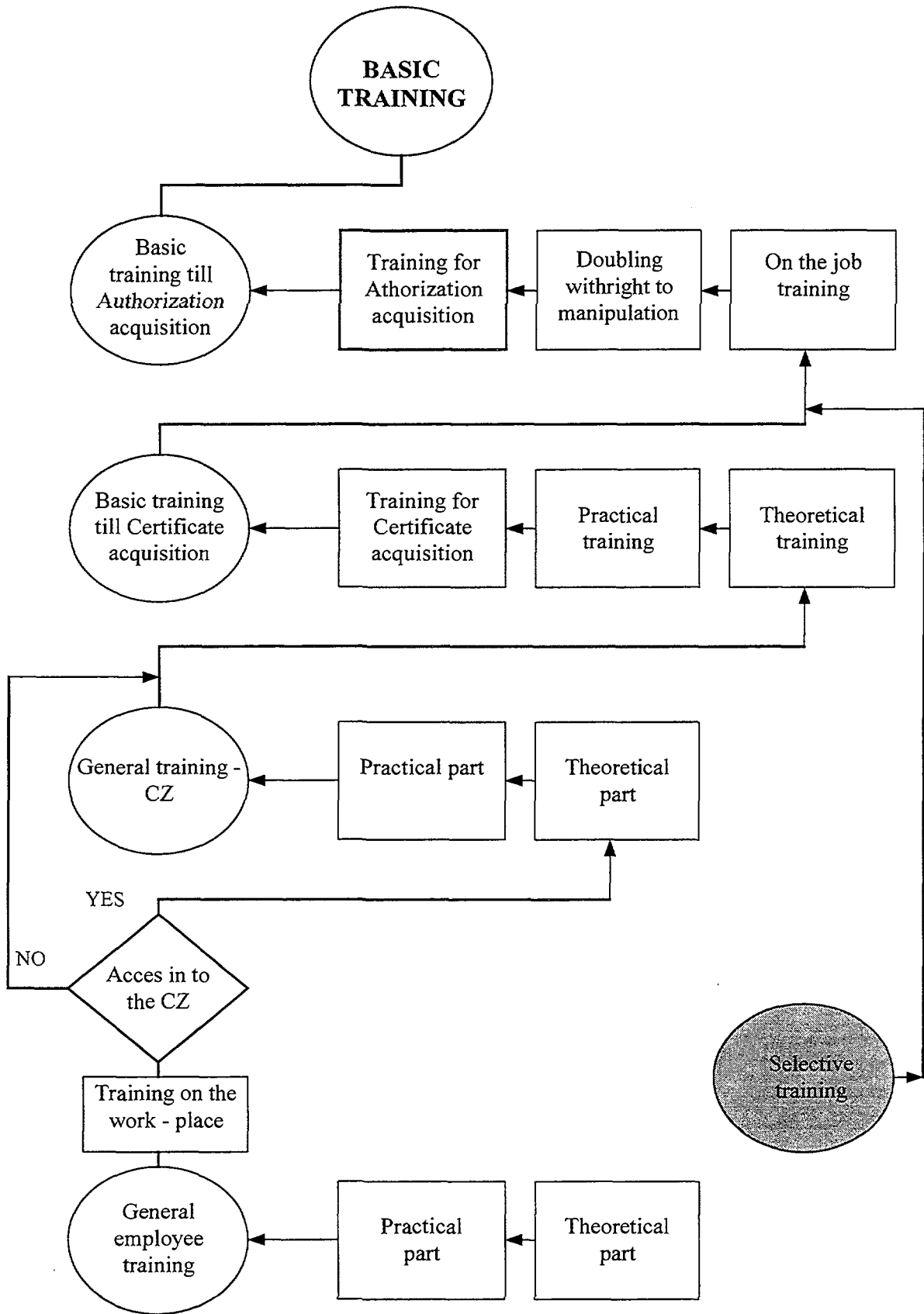

CATEGORY EPSILON

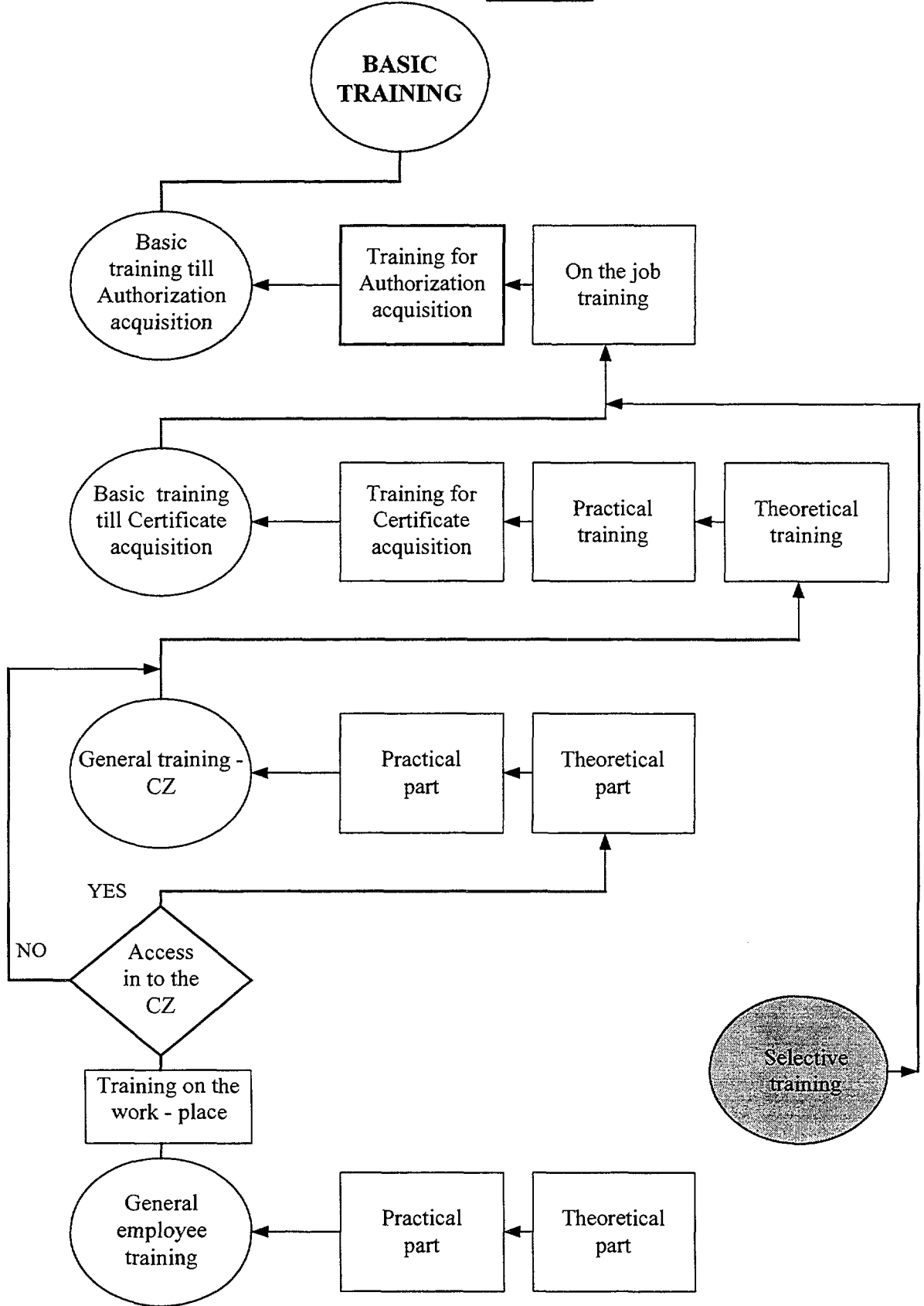

CATEGORY OMEGA

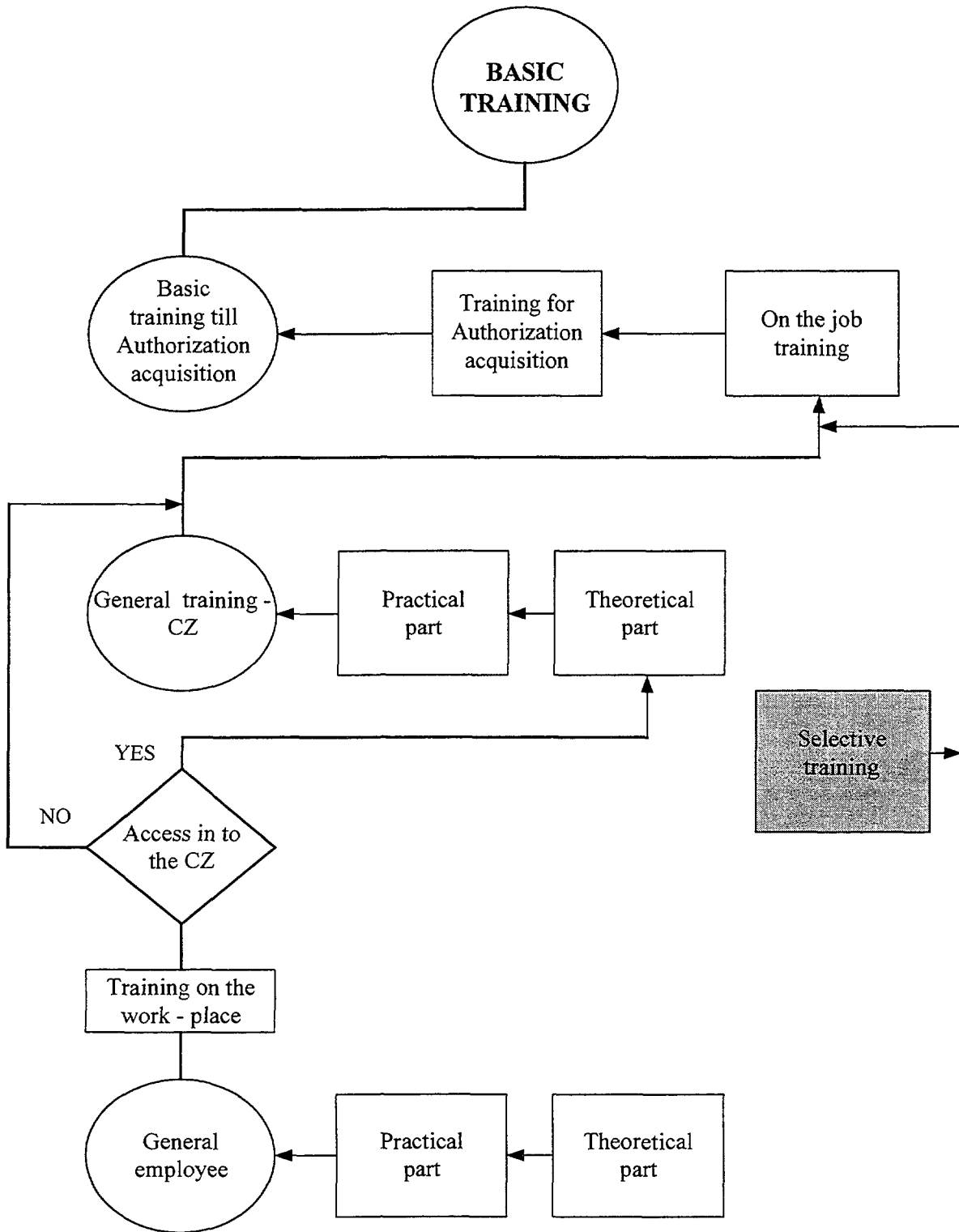

PHASES AND TYPES OF CONTRACTORS TRAINING

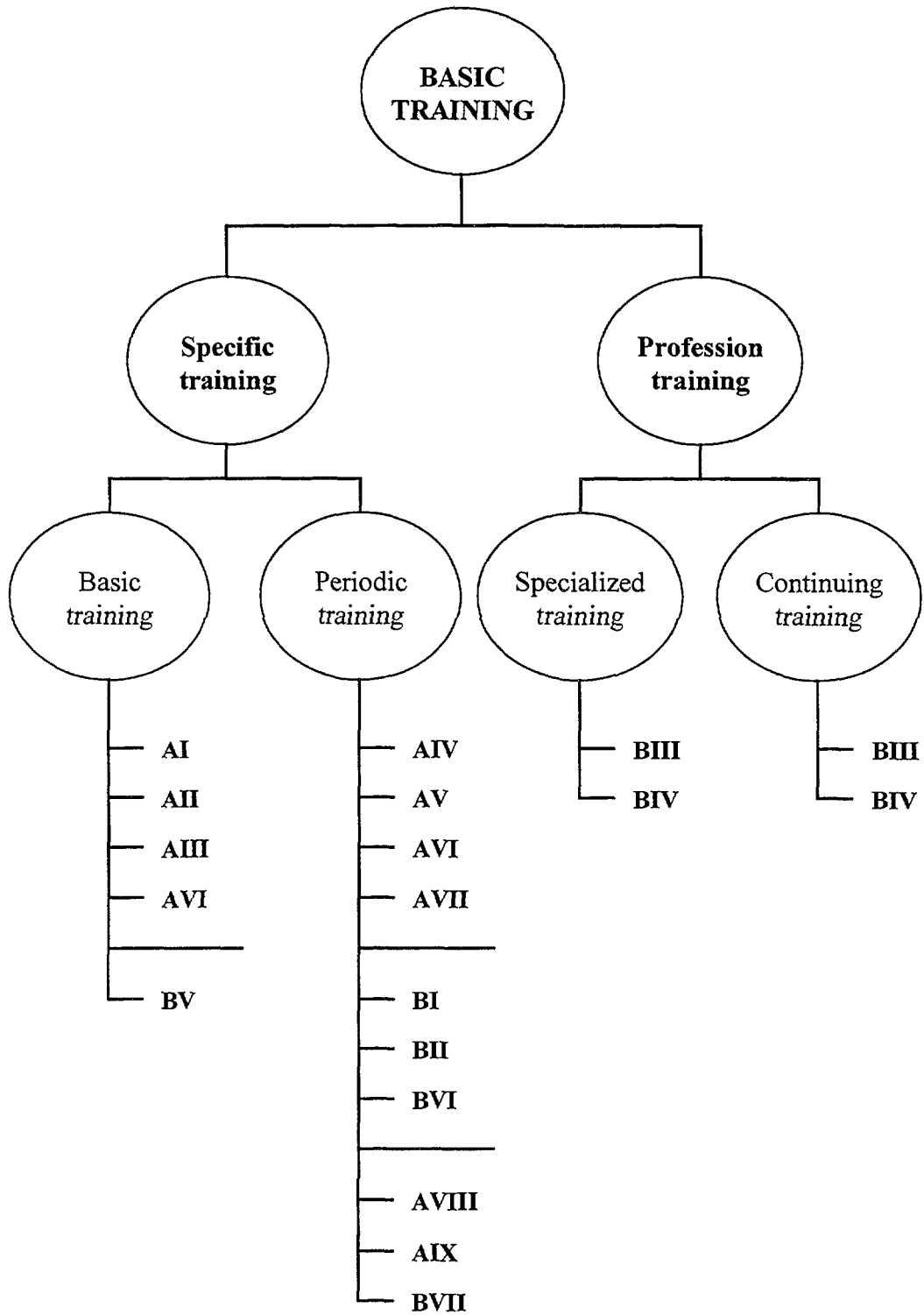

Module Training for Certificate Acquisition

Category β - Control Room Personnel PWR 440

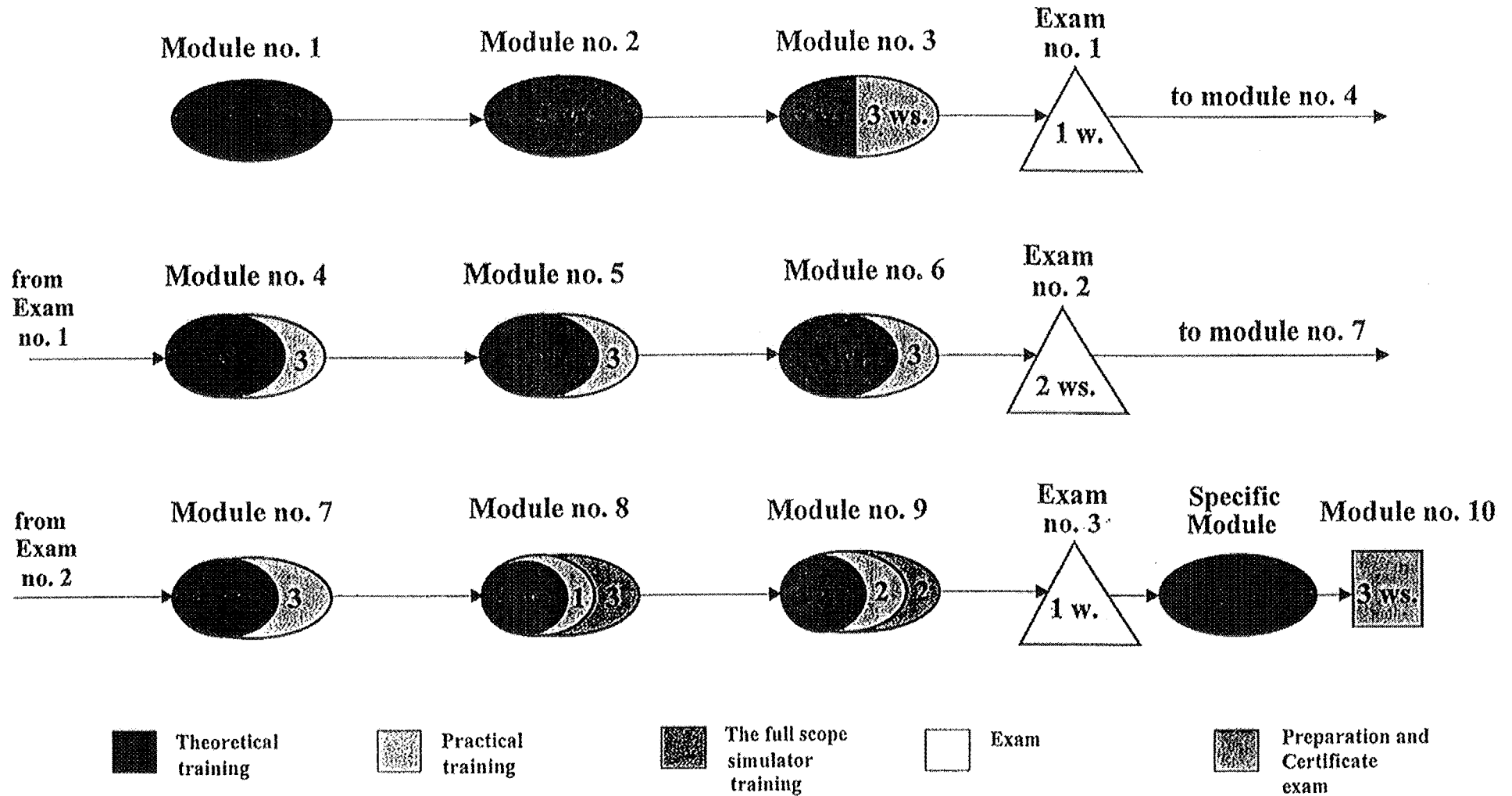

Pict. 1

Licence Acquisition and Authorization for Control Room Personnel PWR 440

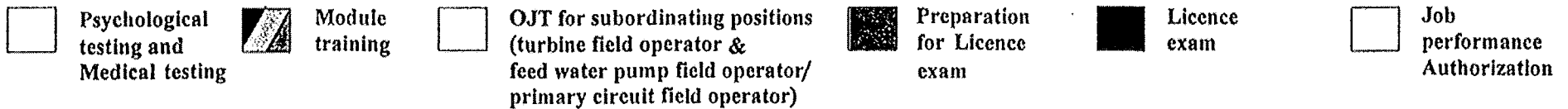
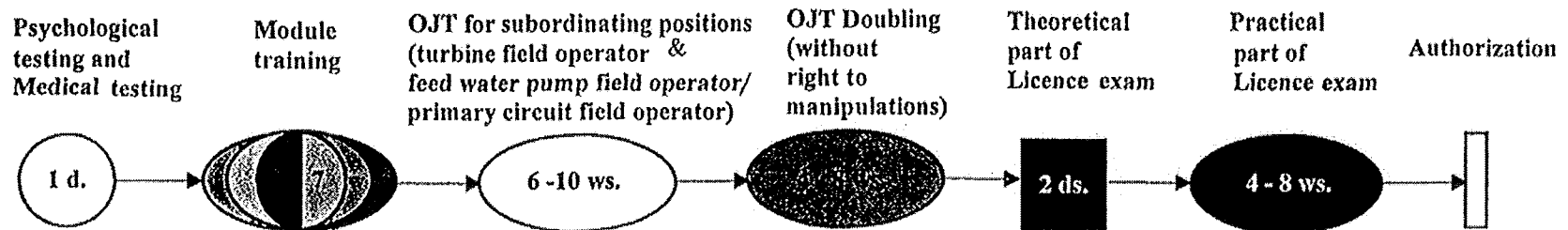

332

Upgrade Training for the Job Positions for Control Room Personnel PWR 440

SCO - Secondary Circuit Operator
 PCO - Primary Circuit Operator
 UO - Unit Operator
 US - Unit Supervisor
 SS - Shift Supervisor

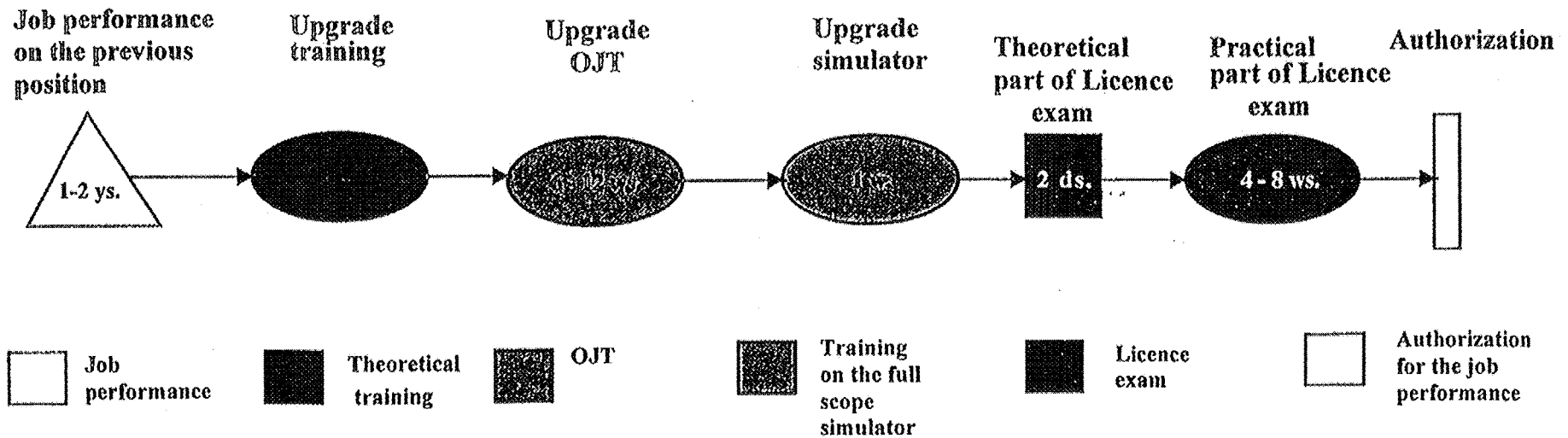
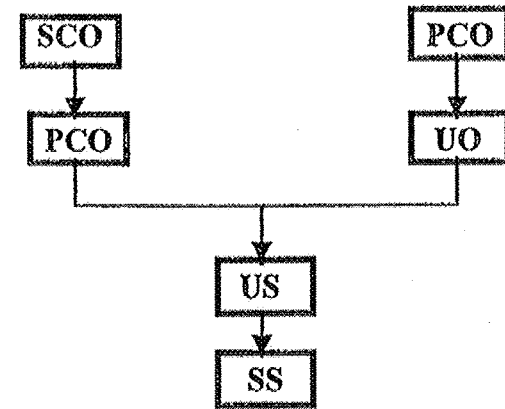

www

Pict. 3

Maintaining and Refresh Training of Control Room Personnel PWR 440

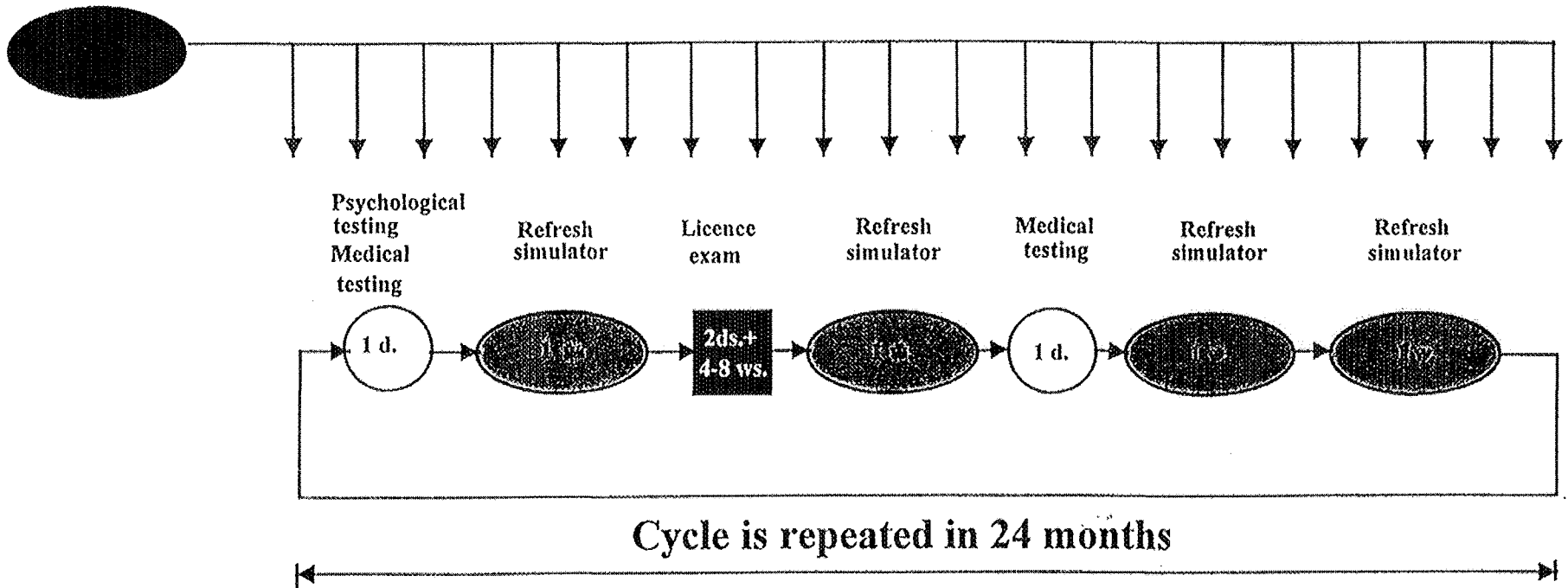

334

■ Training day

■ Periodical training on the full scope simulator

■ Exam for Licence acquisition

□ Psychological testing and (or) Medical testing

Module Training for Certificate Aquisition

Category δ - Servicing Shift and Operating Personnel

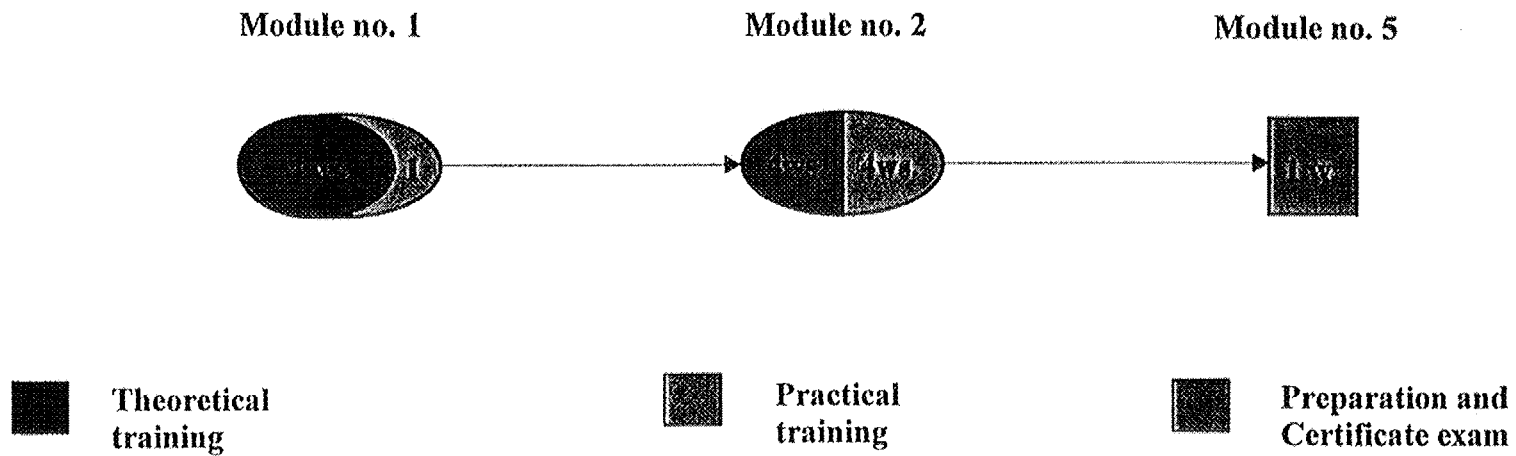

335

Pict. 5

Authorisation Acquisition for Servicing Shift and Operating Personnel PWR 440

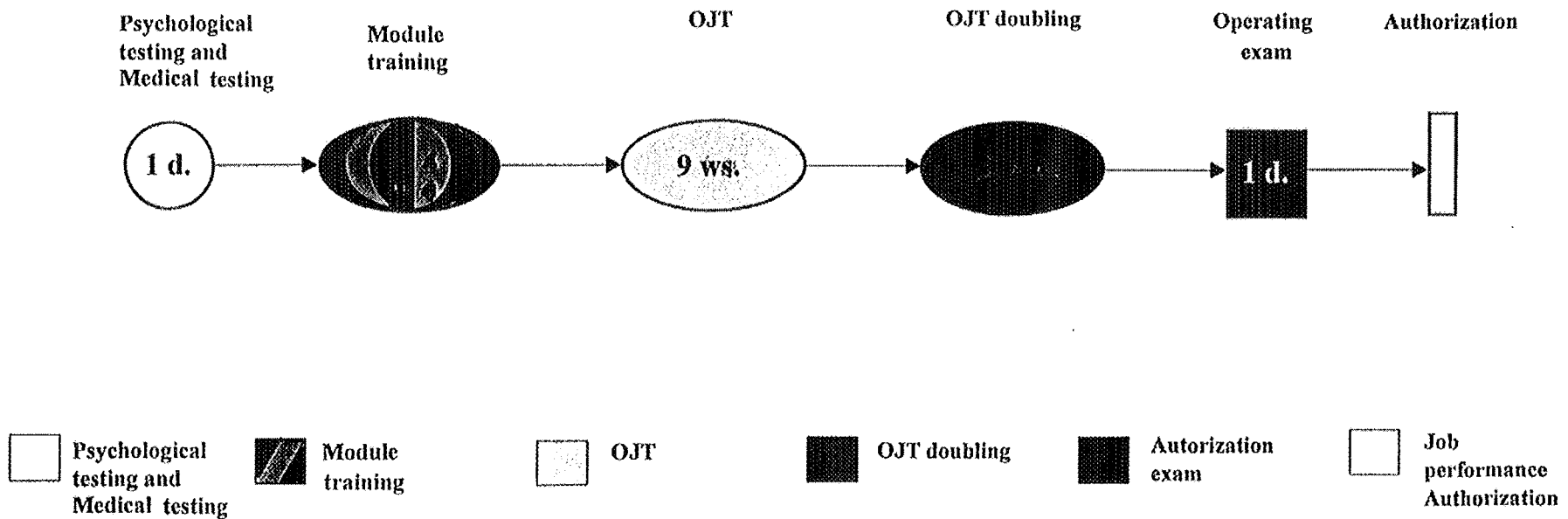

336

Pict. 6

Upgrade Training for the Job Positions for Servicing Shift and Operating Personnel PWR 440

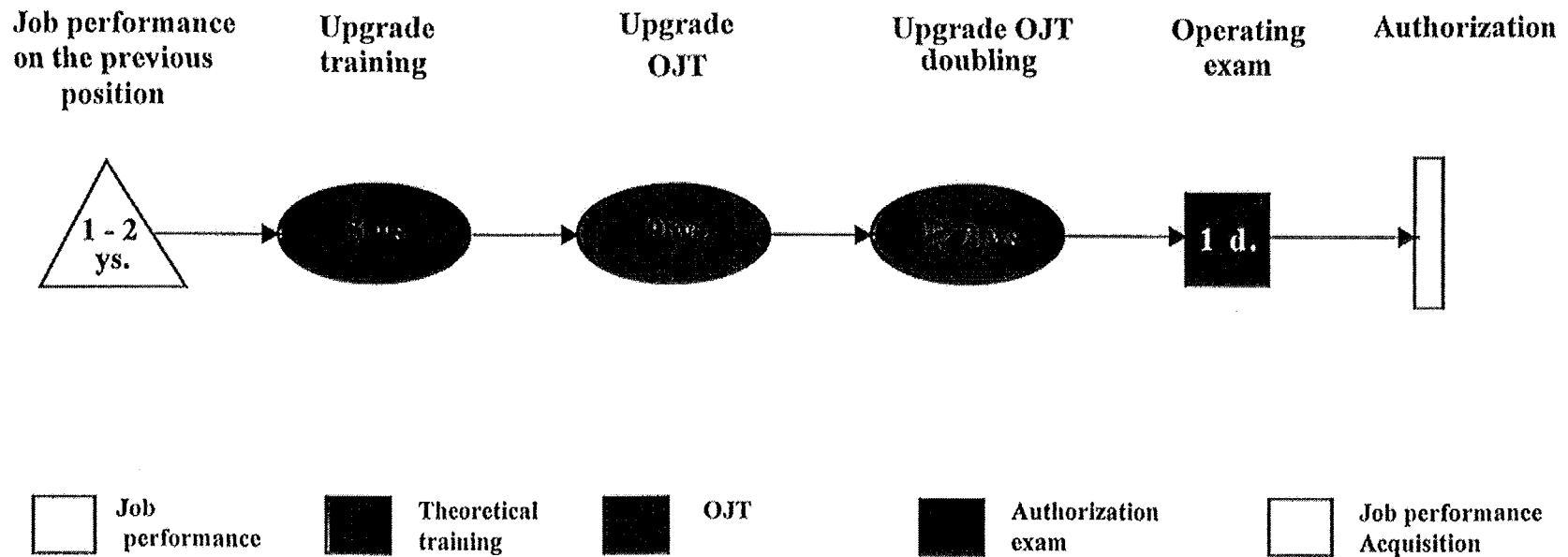

337

Pict. 7

Maintaining and Refresh Training of Servicing Shift and Operating Personnel PWR 440

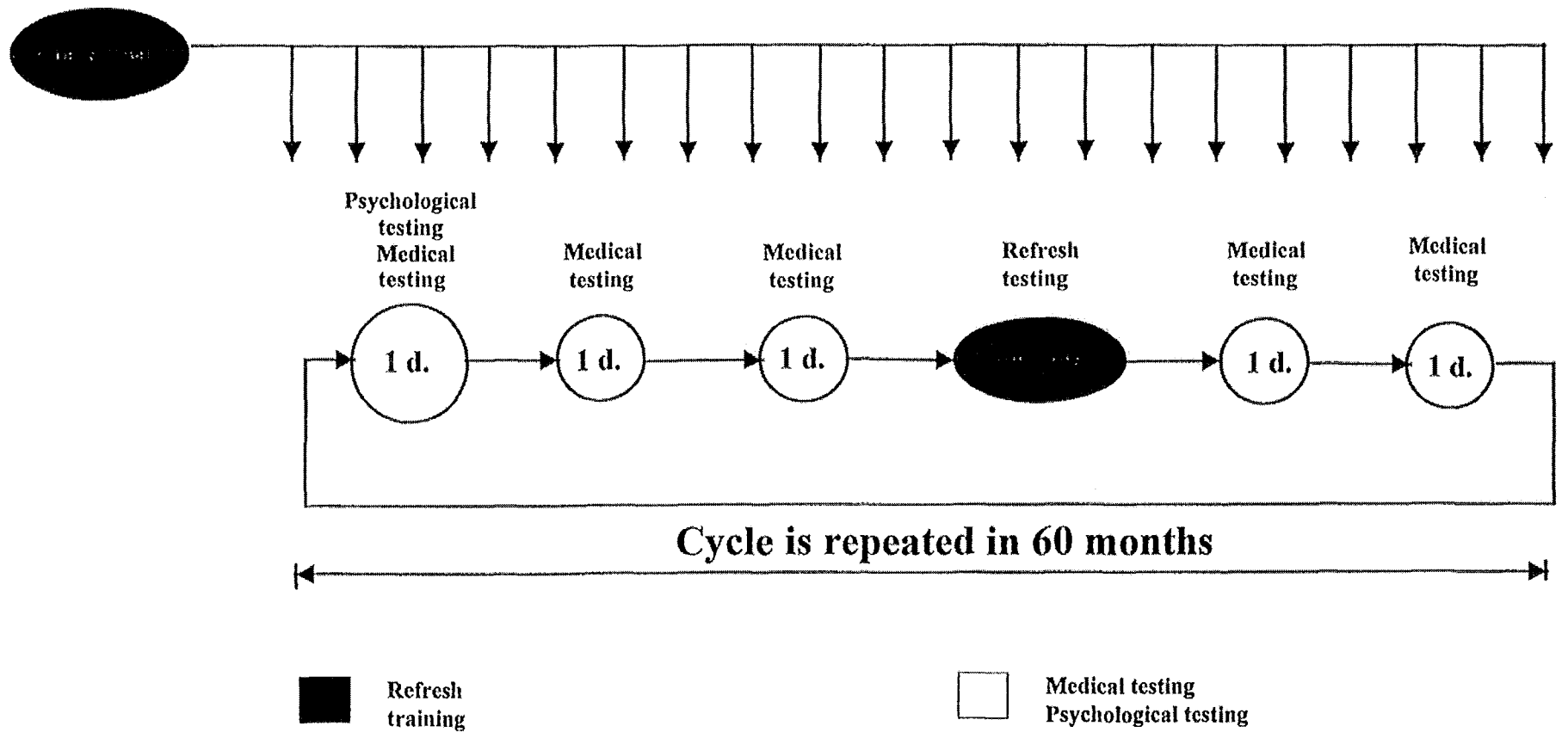

338

Pict. 8

I. A brief description of the training program for the PWR 440 control room operating personnel - job position the NPP Dukovany “primary circuit operator” (reactor operator)

The training program for the control room operating personnel basic training for the job position the NPP Dukovany “primary circuit operator (PCO)” is divided into the following three parts:

1. **basic training** for the start **job position SCO** (secondary circuit operator),
 2. **charge of the job position SCO** (1 - 2 years),
 3. **basic training for the job position PCO;**
- the parts 1 and 3 are further divided into “*training for certificate acquisition*” and “*training for license acquisition and authorization*”

1. The basic training for the job position SCO

1.1 The certificate acquisition basic training, is divided into 11 modules. The modules 1 - 9 consist of:

- **3 - 5 week theoretical training** at the education and training centre (ETC), Brno
- **1 - 3 week practical training** at the NPP Dukovany
- **2 - 3 week training** on the full scope **simulator** at the ETC of the nuclear power research institute (NPRI), Trnava

Each of the three modules is completed by a **1 - 2 week examination period**. The 9th module is followed by a special module containing **one week theoretical training**. The **three week** 10th module include a **training and passing exams for the certificate acquisition**.

The total training period for certificate acquisition (including exams) is 67 weeks (see picture 1).

1.2 The SCO license acquisition and authorization basic training include:

- **a 4 and 6 week training on the related job position “mechanist of power engineering equipment - electro driven feedwater pumps” and “mechanist of power engineering equipment - turbine generator”.**
- **a 4 - 8 week training for the license acquisition exams** (doubling without right to manipulations)
- **license examinations** before a national examining committee (consist of a **theoretical** written and oral part, and a **4 - 8 week practical** part passed as a doubling with right to manipulations as determined by the examining committee).

- **license acquisition and authorization for the job position SCO** (see picture 2)

2. SCO job performance at the NPP Dukovany (1 - 2 years)

This means **the independent performance of the job position SCO** during the real operation of the NPP Dukovany, i.e. manipulation at the main and emergency control room, the put into service management and control, and the management and control of the reactor unit secondary part operation.

3. The job position PCO basic training

It is a special form of basic training and is divided into the stage **“training for the charge of a new job position”** and the stage **“training for license acquisition and authorization”** (see picture 3).

3.1 The stage “training for the charge of a new job position” consists of:

- **one week theoretical training** at the ETC, Brno
- **one week training** on the full scope **simulator** at the ETC of the nuclear power research institute, Trnava

3.2 The stage “training for the PCO license acquisition and authorization”

This training stage complete the whole training of the PCO job position and its main content is:

- **10 week training on the PCO job position** at the NPP Dukovany
- **exams for the license acquisition** before a national examining committee (consists of **theoretical** writing and oral part and **practical** part passed as a **4 - 8 week** doubling with right to manipulations as determined by the examining committee),
- **the license acquisition and authorization for the job position PCO.**

II. A review of the periodic training forms for the primary circuit operator (PCO)

- **Periodic training**, which consists of the following two basic forms: **theoretic training**, represent what is called the “training days” of the control

room personnel. They are carried out **ten times a year** of total **80 hour period of duration**

- **training on the full scope simulator** realized as **one week training period two times a year.**

The pass out of the periodic training is a condition for the admission to the examination before the national examining committee for the renewal of the "license" validity - **the attestation of the professional capability** is carried out each **two years.**

In addition to the above mentioned form of periodic professional training, it is necessary, for the PCO job position, to maintain and refresh all the prescribed **specialized training courses**, such as safety and health protection for work, fire protection, access to the controlled area, etc., in the public note or internal instructions prescribed period.

Further condition for the authorization validity is to maintain **the health and psychological capability** passing out the medical preventive checkup **once a year** and psychological test **once each two years.**

The course of maintaining and refreshing the professional capability is demonstrated on picture 4.

III. A brief description of the training program for the PWR 440 servicing shift and operating personnel basic training (field operators) - job positions the NPP Dukovany "mechanist of feedwater pumps" (mechanist of power engineering equipment - electro driven feedwater pump) and turbine-generator mechanist (mechanist of power engineering equipment - turbine generator)

The training program for the servicing shift and operating personnel basic training for the job position the NPP Dukovany "turbine-generator mechanist" is divided into three parts:

1. **basic training** on the start job position **mechanist of power engineering equipment - electro driven feedwater pumps,**
2. **charge of the job position "mechanist of power engineering equipment - electro driven feedwater pumps (1 - 2 years)**
3. **basic training on the job position "mechanist of power engineering equipment - turbine generator;**

the parts 1 and 3 are further divided into the stages "*training for certificate acquisition*" and "*training for authorization acquisition*".

1. Basic training for the job position “mechanist of power engineering equipment - electro driven feedwater pumps

1.1 Basic training for certificate acquisition, is divided into three modules (modules no, 1, 2 and 5). The modules no. 1 and 2 includes:

- **4 and 4 week theoretical training** at the education and training centre, Brno
- **1 and 4 week practical training** at the NPP Dukovany

Module no. 5 of **one week duration** include **a training and passing exams for certificate acquisition.**

The whole training for certificate acquisition (including examinations) takes **14 week time** (see picture 5).

1.2 Basic training for the authorization acquisition for the job function mechanist of power engineering equipment - electro driven feed water pumps represent:

- **9 week training on the job position mechanist of power engineering equipment - electro driven feedwater pumps,**
- **doubling with right to manipulation of 2 week period as a minimum,**
- **passing exams on the manipulation and operating procedures, and safety and health protection for work** (operating examination).

The whole training for the job position ends by the acquisition of **an authorization for the charge of the job position mechanist of power engineering equipment - electro driven feedwater pumps** (see picture 6).

2. Job performance at the NPP Dukovany (1 - 2 years)

This concerns **the independent performance of the job position “mechanist of power engineering equipment - electro driven feedwater pumps”** during the real operation of the NPP Dukovany, i.e., manipulation on the electro driven feedwater pumps and after-cooling equipment, control the operation of the relative equipment of the reactor secondary circuit.

3. Basic training for the job position “mechanist of power engineering equipment - turbine generator

It is a special form of basic training and is divided into the stages **“training for the charge of a new job position”** and **“training for authorization acquisition”** (see picture 7).

3.1 The stage “training for the charge of the new job position” represent:

- **5 week theoretical and trainer training** (basic class for the TG mechanists)

3.2 The stage training for authorization acquisition for the job position “mechanist of power engineering equipment - turbine generator”

This training stage complete the whole training for the job position “mechanist of power engineering equipment - turbine generator” and its main contents are:

- **9 week training for the job position** at the NPP Dukovany,
- **doubling with right to manipulation of 2 week period as a minimum,**
- **passing examinations on manipulation and operating procedures, and safety and health protection for work** (operating examination),
- **the acquisition of the authorization for the charge of the job position “mechanist of power engineering equipment - turbine generator”**

IV. A review of the periodic training forms for the servicing shift and operating personnel

Periodic training - in the case of the job position “mechanist of power engineering equipment - turbine generator” consists of the following two basic forms:

- **theoretic training**, represents what is called “the training days” of the servicing shift and operating personnel. It is carried out **four times a year** with a total duration of **32 hours**.
- **refresh training for the turbine-generator mechanists**, lasts **one week** and carried out **once each four years**.

In addition to the above mentioned periodic professional training form, it is necessary, for the job position “mechanist of power engineering equipment - turbine generator”, to maintain and refresh the eventual other **professional and safety training**, such as the examination on servicing pressure vessels, electric power equipment operation, safety and health protection for work, fire protection, etc., in the public note or internal instructions prescribed periods.

Another condition for the renewal of the authorization validity is to maintain the health and psychological capabilities passing out a medical preventive checkup **once a year** and a profession psychological test **once each five years**.

The course of maintaining and refreshing the professional capabilities is demonstrated on picture 8.