

SK #4  
 JUL 25 1998

15

ENGINEERING DATA TRANSMITTAL

Page 1 of 1  
 1. EDT 622271

2. To: (Receiving Organization) SST Retrieval		3. From: (Originating Organization) SST Retrieval		4. Related EDT No.: NA	
5. Proj./Prog./Dept./Div.: W-320		6. Design Authority/ Design Agent/Cog. Engr.: JR Kriskovitch		7. Purchase Order No.: NA	
8. Originator Remarks: For Approval and Release				9. Equip./Component No.: POR-007/POR-008	
				10. System/Bldg./Facility: 200 General	
11. Receiver Remarks:				11A. Design Baseline Document? <input type="checkbox"/> Yes <input checked="" type="checkbox"/> No	
				12. Major Assm. Dwg. No.: H-14-102610	
				13. Permit/Permit Application No.: NA	
				14. Required Response Date: July 24, 1998	

15. DATA TRANSMITTED					(F)	(G)	(H)	(I)
(A) Item No.	(B) Document/Drawing No.	(C) Sheet No.	(D) Rev. No.	(E) Title or Description of Data Transmitted	Approval Designer	Reason for Transmittal	Originator Disposition	Receiver Disposition
1	HNF-2027		0	Portable Exhauster Storage Plan	Q,S	1,2	1	

16. KEY			
Approval Designer (F)	Reason for Transmittal (G)		Disposition (H) & (I)
E, S, O, D or N/A (see WHC-CM-3-5, Sec.12.7)	1. Approval 2. Release 3. Information	4. Review 5. Post-Review 6. Dist. (Receipt Acknow. Required)	1. Approved 2. Approved w/comment 3. Disapproved w/comment 4. Reviewed no/comment 5. Reviewed w/comment 6. Receipt acknowledged

17. SIGNATURE/DISTRIBUTION (See Approval Designer for required signatures)											
(G) Reason	(H) Disp.	(J) Name	(K) Signature	(L) Date	(M) MSIN	(G) Reason	(H) Disp.	(J) Name	(K) Signature	(L) Date	(M) MSIN
1	1	Design Authority	<i>JW Bailey</i>	7/24/98	2-48	1	1	JR Kriskovitch	<i>JR Kriskovitch</i>	7-24-98	92-48
		Design Agent				1	1	SW Shaw	<i>SW Shaw</i>	7/24/98	92-48
1	1	Cog. Eng. TD Kaiser	<i>TD Kaiser</i>	7-24-98	14-07	3		Project W-320 Files		7-24-98	RI-29
1	1	Cog. Mgr. RE Larson	<i>RE Larson</i>	7-24-98	14-07						
1	1	QA KC Conrad	<i>Keith Conrad</i>	7-24-98	52-48						
1	1	Safety SU Zaman	<i>SU Zaman</i>	7-24-98	85-12						
		Env.									

18. <i>SW Shaw</i> 7/28/98 Signature of EDT Originator Date		19. JW Lentsch Authorized Representative Date for Receiving Organization		20. <i>JW Bailey</i> 7/25/98 Design Authority/ Cognizant Manager Date		21. DOE APPROVAL (if required) Ctrl. No. <input type="checkbox"/> Approved <input type="checkbox"/> Approved w/comments <input type="checkbox"/> Disapproved w/comments	
--	--	---	--	--	--	--	--

## Portable Exhauster POR-007/Skid E and POR-008/Skid F Storage Plan

OD Nelson  
NHC, Richland, WA 99352  
U.S. Department of Energy Contract DE-AC06-96RL13200

EDT/ECN: 622271 UC: 510  
Org Code: 8C452 Charge Code: D2M65  
B&R Code: EW3130010 Total Pages: 44

Key Words: Storage, Portable Exhauster, POR-007, POR-008, FMEF, TWRS, W-320, Maintenance

Abstract: Describes the storage requirements for 1,000 CFM Portable Exhausters POR-007 and POR-008 at FMEF. Includes a description of periodic maintenance requirements and functional testing to be performed.

TRADEMARK DISCLAIMER. Reference herein to any specific commercial product, process, or service by trade name, trademark, manufacturer, or otherwise, does not necessarily constitute or imply its endorsement, recommendation, or favoring by the United States Government or any agency thereof or its contractors or subcontractors.

Printed in the United States of America. To obtain copies of this document, contact: Document Control Services, P.O. Box 950, Mailstop H6-08, Richland WA 99352, Phone (509) 372-2420; Fax (509) 376-4989.

Janis Braden  
Release Approval

7/25/98  
Date

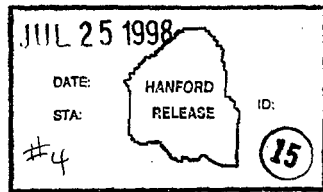

Release Stamp

Approved for Public Release

**HNF-2027**  
**Rev. 0**

**PORTABLE EXHAUSTERS**

**POR-007-SKID E**

**POR-008-SKID F**

**STORAGE PLAN**

**B. D. Andres**  
**SGN Eurisys Services Corporation**  
**Richland, Washington**

**April 1998**

HNF-2027  
Rev. 0

TABLE OF CONTENTS

1.0	OBJECTIVE .....	1
2.0	PREPARATION FOR STORAGE .....	1
2.1	EXHAUSTER ARRANGEMENT .....	1
2.2	SKID .....	1
2.2.1	Support Jacks .....	1
2.2.2	Paint .....	1
2.3	FILTER TRAIN .....	2
2.3.1	Filters .....	2
2.3.1.1	Pre-filter .....	2
2.3.1.2	HEPA filter .....	2
2.3.2	Access doors .....	2
2.3.3	Filter Train Isolation Valves .....	2
2.3.4	Filter Train Inlet And Outlet Isolation .....	2
2.4	SEAL POT SYSTEM .....	2
2.4.1	Seal Pot .....	2
2.4.2	Drain line Valves .....	3
2.5	GLYCOL HEATER SYSTEM .....	3
2.6	DEMISTER .....	3
2.7	EXHAUST STACK .....	3
2.7.1	Exhaust Stack .....	3
2.7.2	Tubing .....	4
2.8	EXHAUST FAN .....	4
2.9	ELECTRICAL COMPONENTS .....	4
2.9.1	Message View Cabinet .....	4
2.9.2	Action Paks .....	4
2.9.3	Intrinsic Cabinet .....	4
2.9.4	Yokogawa Pressure Transmitters .....	4
2.9.5	Control Cabinet .....	5
2.9.6	Drexelbrook Liquid Level Transmitters and Probe .....	5
2.9.7	Wilkerson Indicators .....	5
2.10	CHECKLIST .....	5
3.0	STORAGE MAINTENANCE AND TESTING .....	5
3.1	SUPPORT JACKS .....	5
3.2	INSULATION .....	5
3.3	FILTER TRAIN ISOLATION .....	6
3.4	STACK ISOLATION .....	6
3.5	FAN SHAFT ROTATION .....	6
3.6	FUNCTIONAL TESTING .....	6
3.7	CHECKLIST .....	6

**HNF-2027**  
**Rev. 0**

4.0	RETRIEVAL FROM STORAGE	7
4.1	EXHAUSTER	7
4.2	SKID	7
4.2.1	Support Jacks	7
4.2.2	Paint	7
4.3	FILTER TRAIN	7
4.3.1	Filters	7
4.3.1.1	Pre-filter	7
4.3.1.2	HEPA filter	7
4.3.2	Access doors	8
4.3.3	Filter Train Isolation Valves	8
4.3.4	Filter Train Inlet and Outlet Isolation	8
4.3.5	Filter Train Insulation	8
4.3.6	Filter Train Interior	8
4.4	SEAL POT SYSTEM	9
4.4.1	Seal Pot	9
4.4.2	Drain line Valves	9
4.5	GLYCOL HEATER SYSTEM	9
4.6	EXHAUST STACK	9
4.6.1	Exhaust Stack	9
4.6.2	Tubing	9
4.7	EXHAUST FAN	10
4.8	ELECTRICAL COMPONENTS	10
4.8.1	Message View Cabinet	10
4.8.2	Action Paks	10
4.8.3	Intrinsic Cabinet	10
4.8.4	Yokogawawa Pressure Transmitters	10
4.8.5	Control Cabinet	10
4.8.6	Drexelbrook Liquid Level Transmitters and Probe	11
4.9	CHECKLIST	11
5.0	ORGANIZATIONAL RESPONSIBILITIES	11
6.0	FUNDING	11

**HNF-2027**  
**Rev. 0**

APPENDIX A  
STORAGE CHECKLIST ..... A-1

APPENDIX B  
STORAGE MAINTENANCE AND TESTING CHECKLIST ..... B-1

APPENDIX C  
RETRIEVAL FROM STORAGE CHECKLIST ..... C-1

APPENDIX D  
FUNCTIONAL TEST ..... D-1

## 1.0 OBJECTIVE

This document provides storage requirements for portable exhausters POR-007-Skid E and POR-008-Skid F. These requirements are presented in three parts: preparation for storage, storage maintenance and testing, and retrieval from storage. The exhauster component identification numbers listed in this document contain the prefix POR-007 or POR-008 depending on which exhauster is being used. These prefixes will not be used throughout this document.

## 2.0 PREPARATION FOR STORAGE

### 2.1 EXHAUSTER ARRANGEMENT

The portable exhausters will be stored inside Building 427 (FMEF) located in the 400 Area of the Hanford Site.

### 2.2 SKID

#### 2.2.1 Support Jacks

In order to prevent the formation of corrosion on the slide mechanism, coat all exposed sliding surfaces with a grease that meets the requirements of MIL-G-10924.

#### 2.2.2 Paint

Inspect the painted surfaces of the exhauster skid for the presence of corrosion. If corrosion is detected, remove the corrosion and paint the surface with two coats of a paint meeting the requirements for outside operation. The finish color shall be grey. Apply paint per manufacturer's instructions.

## **2.3 FILTER TRAIN**

### **2.3.1 Filters**

#### **2.3.1.1 Pre-filter**

Remove the pre-filter and place the pre-filter into a plastic storage bag. Place the pre-filter into storage with the portable exhauster.

#### **2.3.1.2 HEPA filter**

Remove the first and second stage HEPA filters. Cover both faces of the HEPA filter with 18 gauge 304L stainless steel covers or store in manufacturer's original boxes. Secure both covers to the HEPA filter with adhesive tape and place the HEPA filters into storage location identified for the portable exhausters. For each of the HEPA filters, label one of the stainless steel covers with "H-14-102578 Rev 0, Part #116" using ½" high letters and black spray paint. Store with the portable exhausters.

### **2.3.2 Access doors**

Close and latch the access doors for the prefilter and both HEPA filters. Secure the latching mechanism so that the gasket on these doors is compressed.

### **2.3.3 Filter Train Isolation Valves**

Place both the 12" and 8" filter train isolation valves in the fully closed position.

### **2.3.4 Filter Train Inlet And Outlet Isolation**

At the completion of section 2.6, place an isolation cover (plywood or engineering approved equal) on the 12" inlet flange and the 10" flange on top of the lower stack section and secure in place using duct tape around the perimeter to prevent any undesired objects from entering the filter train.

## **2.4 SEAL POT SYSTEM**

### **2.4.1 Seal Pot**

With valves VTP-V-158, -161, -162, -163, -164, -165, and -166 open, tilt the



## HNF-2027

Rev. 0

exhauster in the direction of the seal pot drain and drain the seal pot by opening Seal Pot drain valve VTP-V-160. Drain the contents into a suitable container. Close valves VTP-V-161, -163, -164, -165, and -166. Connect pressurized air to the seal pot fill valve, VTP-V-162, and allow a maximum 10 psig compressed air to flow through the seal pot for a minimum of 5 minutes. Inspect each of the drains in the filter train and fan housing to ensure moisture was not blown into the filter train. If so, remove the moisture.

### 2.4.2 Drain line Valves

Close the Seal Pot overflow valve (VTP-V-161), Seal Pot drain valve (VTP-V-160), seal pot pumped drain (VTP-V-166), seal pot fill valve (VTP-V-162), and fan drain line valve (VTP-V-158).

## 2.5 GLYCOL HEATER SYSTEM

Close valves VTP-V-201, -202, -203, -204, and glycol system drain valve VTP-V-205. If glycol system is charged verify glycol is good for -30°F.

## 2.6 DEMISTER

Open the 12" inlet valve (VTP-V-135) and the pre-filter (VTP-FLT-001) door. Connect pressurized air to the water coupling that is prior to pressure regulator VTP-PRV-001. Allow a maximum 50 psig compressed air to flow through the demister for a minimum of 5 minutes. Inspect the bottom of the demister housing through VTP-V-135 for water. If water is visible, remove the water. Remove pressurized air to the demister. Replace pre-filter (VTP-FLT-001) door per section 2.3.2 and close inlet valve (VTP-V-135).

## 2.7 EXHAUST STACK

### 2.7.1 Exhaust Stack

If stored with the upper section of the exhaust stack removed cover both the inlet and outlet of the stack with an isolation cover (plywood or engineering approved equal) to prevent any unwanted objects from entering the stack.

### **2.7.2 Tubing**

If stored with the upper section of the exhaust stack removed cap the two 1/4" stainless steel tubes that go to the stack flow instrument (Verabar). Use plastic tubing caps or engineering approved equal.

## **2.8 EXHAUST FAN**

Lubricate the fan motor and shaft bearings with Shell Alavania™<sup>1</sup> EP2 Lf grease before placing the exhauster into storage.

## **2.9 ELECTRICAL COMPONENTS**

### **2.9.1 Message View Cabinet**

Ensure that the Message View cabinet front panel has been properly closed.

### **2.9.2 Action Paks**

Because of vibrations while moving the system to a storage location, it would be advisable to remove the action paks and store the system with these Limit Alarms removed. These are easily removed and installed 11-pin cubes.

### **2.9.3 Intrinsic Cabinet**

Ensure that the intrinsic cabinet front panel has been properly closed and secured.

### **2.9.4 Yokogawa Pressure Transmitters**

Open all DA manifold valves to the following transmitters VTP-PDT-177, -178, -179, -180, -181, and -182 to allow some small pressure changes in the transmitters diaphragm housing.

---

<sup>1</sup>Shell Oil Company, 900 Louisiana Street, Houston, Texas 77002, 800/231-6950

### **2.9.5 Control Cabinet**

Ensure that the weather covers on the control cabinet have been properly installed if stored outside and the control panel front panel has been properly secured.

### **2.9.6 Drexelbrook Liquid Level Transmitters and Probe**

Ensure that the liquid level transmitters weather covers O-rings are in good condition and cover is completely closed.

### **2.9.7 Wilkerson Indicators**

There are no special storage requirements for the Wilkerson indicators. These should remain in place during storage.

## **2.10 CHECKLIST**

A checklist of all the actions to place the portable exhausters into storage is presented in Appendix A.

## **3.0 STORAGE MAINTENANCE AND TESTING**

### **3.1 SUPPORT JACKS**

Inspect the support jacks for signs of corrosion or dirt on the sliding mechanism. Re-lubricate outer surface of inner tube assembly with a light coating of a grease that meets the requirements of MIL-G-10924 as required per the direction of the cognizant engineer.

### **3.2 INSULATION**

Inspect the filter train and drain line insulation for signs of deterioration and cracking in the protective coating. Replace any deteriorated insulation with Armstrong

**HNF-2027**  
**Rev. 0**

Armaflex II™<sup>2</sup> sheet insulation. Insulation shall be secured with Armstrong 520™ adhesive. Apply per manufacturer's instructions. Protective coating shall be Armstrong standard white color. Apply per manufacturer's instructions.

**3.3 FILTER TRAIN ISOLATION**

Ensure that the isolation covers are in place on the filter train inlet and outlet.

**3.4 STACK ISOLATION**

If stored with the upper stack removed ensure that the isolation covers for the exhaust stack are in place.

**3.5 FAN SHAFT ROTATION**

On a monthly basis, rotate the fan shaft at least ten rotations by hand to ensure that the shaft bearings do not develop flat spots. Note the initial position of the fan shaft using the shaft keyway as a reference. After the ten shaft rotations, ensure that the keyway is +/- 90 degrees from the initial position.

**3.6 FUNCTIONAL TESTING**

The functional test in Appendix D shall be completed annually.

**3.7 CHECKLIST**

A checklist that lists all of the actions for storage inspections and maintenance is presented in Appendix B.

---

<sup>2</sup>Armstrong World Industries, Inc., Lancaster, PA, 717/397-0611

## **4.0 RETRIEVAL FROM STORAGE**

### **4.1 EXHAUSTER**

Perform a general cleanup of the outer surfaces of the exhauster to remove dust and any other surface contamination. The cleaning process shall be determined by the cognizant engineer

### **4.2 SKID**

#### **4.2.1 Support Jacks**

Extend each jack assembly to the full stroke extension and wipe the jack inner tube assembly with a cloth to eliminate any sand or abrasive particles from the surface. Re-lubricate outer surface of inner tube assembly with light coating of a grease that meets the requirements of MIL-G-10924).

#### **4.2.2 Paint**

Inspect the painted surfaces on the portable exhausters for corrosion. If corrosion is detected, remove the corrosion and paint the surface with two coats of a paint meeting the requirements for outside operation. The finish color shall be grey. Apply paint per manufacturer's instructions.

### **4.3 FILTER TRAIN**

#### **4.3.1 Filters**

##### **4.3.1.1 Pre-filter**

Remove the pre-filter from storage and inspect for damage. If damage is discovered, replace with Part #117 of H-14-102578, Sheet 2. Reinstall pre-filter into the portable exhauster.

##### **4.3.1.2 HEPA filter**

Remove the HEPA filters from storage and inspect for damage. If damage is

## HNF-2027

Rev. 0

discovered, replace with Part #116 of H-14-102578, Sheet 2. Remove the stainless steel face covers that were attached when the HEPA filters was placed into storage. Remove the used fluid seal gel from the HEPA filter and reinstall fresh Flanders Filters™<sup>3</sup> fluid seal gel (Flanders Filters part numbers E0600299 and E0600300). Reinstall HEPA filters in the portable exhauster.

### **4.3.2 Access doors**

Close and latch the access doors for the prefilter and both HEPA filters after the filters have been installed. Secure the latching mechanism so that the gaskets on the access doors are evenly compressed.

### **4.3.3 Filter Train Isolation Valves**

Open and close both the 12" and 8" filter train isolation valves to ensure that the valves still operate normally.

### **4.3.4 Filter Train Inlet and Outlet Isolation**

Remove the isolation plates from the inlet and outlet flanges.

### **4.3.5 Filter Train Insulation**

Inspect the filter train and drain line insulation for signs of deterioration and cracking in the protective coating. Replace any deteriorated insulation with Armstrong Armaflex II™ sheet insulation. Insulation shall be secured with Armstrong 520™ adhesive or equal. Apply per manufacturer's instructions. Protective coating shall be Armstrong standard white color. Apply per manufacturer's instructions.

### **4.3.6 Filter Train Interior**

Inspect the interior of the filter train for intrusion by the elements or other contaminants. If detected, clean per the cognizant engineer's instructions.

---

<sup>3</sup>Flanders Filters Inc., 531 Flanders Road, Washington, NC 27889, 919/946-8081

#### **4.4 SEAL POT SYSTEM**

##### **4.4.1 Seal Pot**

Pour a minimum of one gallon of water into each of the following drains while the seal pot drain valve (VTP-V-160 and VTP-V-158) is in the open position and drain into a suitable container:

- a) Pre-filter
- b) First stage test section
- c) First stage HEPA filter
- d) Second stage test section
- e) Second stage HEPA filter
- f) Fan
- g) Demister
- h) Heater coil

Drain the seal pot completely into a suitable container.

##### **4.4.2 Drain line Valves**

After flushing the seal pot, close the seal pot overflow valve (VTP-V-161), seal pot drain valve (VTP-V-160), seal pot pump drain (VTP-V-166), seal pot fill valve (VTP-V-162), and fan drain line valve (VTP-V-158).

#### **4.5 GLYCOL HEATER SYSTEM**

Ensure that the glycol expansion tank/system is at least 3/4 full with a 50-50 mixture of propylene glycol. Verify that the glycol expansion tank vent is not clogged in order to allow the expansion tank to remain at atmospheric pressure.

#### **4.6 EXHAUST STACK**

##### **4.6.1 Exhaust Stack**

Remove any isolation covers placed on the exhaust stack.

##### **4.6.2 Tubing**

Remove any caps placed on the two, 1/4"-stainless steel tubes that go to the stack flow instrument (Verabar).

#### **4.7 EXHAUST FAN**

Lubricate the fan motor and shaft bearings with Shell Alavania EP2 LF™ grease. Rotate the fan shaft a minimum of 10 revolutions by hand.

#### **4.8 ELECTRICAL COMPONENTS**

##### **4.8.1 Message View Cabinet**

Ensure that the Message View cabinet front panel has been properly closed by verifying that excessive dust is not present. If excessive dust is discovered, clean the cabinet per the cognizant engineer's instructions.

##### **4.8.2 Action Paks**

Reinstall action pak modules per H-14-102609 sheet 5.

##### **4.8.3 Intrinsic Cabinet**

Ensure that the Stahl cabinet has been properly closed by verifying that excessive dust is not present. If excessive dust is discovered, clean the cabinet per the cognizant engineer's instructions.

##### **4.8.4 Yokogawawa Pressure Transmitters**

Verify that the DA manifold valves to the filter plenum are open. Close the equalizing valves on the following transmitters VTP-PDT-177, -178, -179, -180, -181, and -182.

##### **4.8.5 Control Cabinet**

Ensure that the Control cabinet has been properly closed by verifying that excessive dust is not present. If excessive dust is discovered, clean the cabinet per the cognizant engineer's instructions.



#### **4.8.6 Drexelbrook Liquid Level Transmitters and Probe**

Ensure that liquid level transmitter weather covers O-rings are in good condition and the cover is completely closed.

#### **4.9 CHECKLIST**

A checklist of all the actions to take the portable exhausters out of storage is presented in Appendix C.

#### **5.0 ORGANIZATIONAL RESPONSIBILITIES**

Project W-320 will have the responsibility of preparing the portable exhausters (POR -007-Skid E and POR-008-Skid F) for storage as defined in this document. Project W-320 will have the responsibility of transporting the portable exhausters and miscellaneous equipment (prefilter, HEPA filters, etc.) from Building 2713WB to the storage location in Building 427 (FMEF) in the 400 Area. Once the exhausters have been placed into storage at Building 427, Project W-320 will maintain ownership of the equipment as described in Numatec Internal Memo 8C620-98-003.

#### **6.0 FUNDING**

Project W-320 will provide the funding to prepare and maintain the portable exhausters (POR -007-Skid E and POR-008-Skid F) through the end of fiscal year 1998. After this date, TWRS DST Operations shall be responsible for funding until the portable exhausters are removed from Building 427 (FMEF).

**HNF-2027**  
**Rev. 0**

**APPENDIX A**  
**STORAGE CHECKLIST**

HNF-2027  
Rev. 0

POR-007-Skid E Storage Checklist

Document Section	Description	Cog. Eng/Date
2.1	Exhauster Arrangement	
2.2.1	Support Jacks	
2.2.2	Paint	
2.3.1.1	Pre-filter	
2.3.1.2	HEPA filters	
2.3.2	Access doors	
2.3.3	Filter Train Isolation Valves	
2.3.4	Filter Train Inlet And Outlet Isolation	
2.4.1	Seal Pot	
2.4.2	Drain Line Valves	
2.5	Glycol Heater System	
2.6	Demister	
2.7.1	Exhaust Stack	
2.7.2	Tubing	
2.8	Exhaust Fan	
2.9.1	Message View Cabinet	
2.9.2	Action Paks	
2.9.3	Intrinsic Cabinet	
2.9.4	Yokogawa Pressure Transmitters	
2.9.5	Control Cabinet	
2.9.6	Drexelbrook Liquid Level Transmitter/Probes	
2.9.7	Wilkerson Indicators	

**HNF-2027**  
**Rev. 0**

**POR-008-Skid F Storage Checklist**

<b>Document Section</b>	<b>Description</b>	<b>Cog. Eng/Date</b>
2.1	Exhauster Arrangement	
2.2.1	Support Jacks	
2.2.2	Paint	
2.3.1.1	Pre-filter	
2.3.1.2	HEPA filters	
2.3.2	Access doors	
2.3.3	Filter Train Isolation Valves	
2.3.4	Filter Train Inlet And Outlet Isolation	
2.4.1	Seal Pot	
2.4.2	Drain Line Valves	
2.5	Glycol Heater System	
2.6	Demister	
2.7.1	Exhaust Stack	
2.7.2	Tubing	
2.8	Exhaust Fan	
2.9.1	Message View Cabinet	
2.9.2	Action Paks	
2.9.3	Intrinsic Cabinet	
2.9.4	Yokogawa Pressure Transmitters	
2.9.5	Control Cabinet	
2.9.6	Drexelbrook Liquid Level Transmitter/Probes	
2.9.7	Wilkerson Indicators	

**HNF-2027**  
**Rev. 0**

**APPENDIX B**  
**STORAGE MAINTENANCE AND TESTING CHECKLIST**





**HNF-2027**  
**Rev. 0**

**APPENDIX C**  
**RETRIEVAL FROM STORAGE CHECKLIST**



HNF-2027  
Rev. 0

POR-007-Skid E Retrieval From Storage Checklist

Document Section	Description	Cog. Eng/Date
4.1	Exhauster	
4.2.1	Support Jacks	
4.2.2	Paint	
4.3.1.1	Pre-filter	
4.3.1.2	HEPA filters	
4.3.2	Access doors	
4.3.3	Filter Train Isolation Valves	
4.3.4	Filter Train Inlet And Outlet Isolation	
4.3.5	Filter Train Insulation	
4.3.6	Filter Train Interior	
4.4.1	Seal Pot	
4.4.2	Drain Line Valves	
4.5	Glycol Heater System	
4.6.1	Exhaust Stack	
4.6.2	Tubing	
4.7	Exhaust Fan	
4.8.1	Message View Cabinet	
4.8.2	Action Pak's	
4.8.3	Intrinsic Cabinet	
4.8.4	Yokogawa Pressure Transmitters	
4.8.5	Control Cabinet	
4.8.6	Drexelbrook Liquid Level Transmitter/Probes	

**POR-008-Skid F Retrieval From Storage Checklist**

<b>Document Section</b>	<b>Description</b>	<b>Cog. Eng/Date</b>
4.1	Exhauster	
4.2.1	Support Jacks	
4.2.2	Paint	
4.3.1.1	Pre-filter	
4.3.1.2	HEPA filters	
4.3.2	Access doors	
4.3.3	Filter Train Isolation Valves	
4.3.4	Filter Train Inlet And Outlet Isolation	
4.3.5	Filter Train Insulation	
4.3.6	Filter Train Interior	
4.4.1	Seal Pot	
4.4.2	Drain Line Valves	
4.5	Glycol Heater System	
4.6.1	Exhaust Stack	
4.6.2	Tubing	
4.7	Exhaust Fan	
4.8.1	Message View Cabinet	
4.8.2	Action Pak's	
4.8.3	Intrinsic Cabinet	
4.8.4	Yokogawa Pressure Transmitters	
4.8.5	Control Cabinet	
4.8.6	Drexelbrook Liquid Level Transmitter/Probes	

**HNF-2027**  
**Rev. 0**

**APPENDIX D**  
**FUNCTIONAL TEST**

## 1.0 PURPOSE

The purpose of this appendix is to provide instructions to start, stop, and operate a 1000 cfm portable exhauster to functionally test the portable exhauster system periodically during storage.

## 2.0 INFORMATION

### 2.1 PERSONNEL SAFETY

Warning - Energized circuits and leads are contained inside the cabinets. Comply with HNF-PRO-088, "Electrical Work Safety".

Warning - Exposed piping and valves on the glycol system may be thermally hot.

### 2.2 TERMS AND DEFINITIONS

- CFM Cubic Feet per Minute
- DP Differential Pressure
- inWG Inches Water Gauge
- HEPA High Efficiency Particulate Air

### 2.3 SPECIAL TOOLS AND EQUIPMENT

- Portable Calibration System (C-Box) Model 401-18-20 by Drexelbrook
- Yokogawa hand held transmitter configurer BT-200
- Desktop/Laptop computer to interface with the Exhauster SLC Logic program.

### 2.4 PREREQUISITES

- 2.4.1 Pre-Filter shall be installed.
- 2.4.2 First and second stage HEPA filters shall be installed.
- 2.4.3 Isolation covers shall be removed from the 12" inlet flange and the 10" flange on top of the lower stack section.
- 2.4.4 Action Paks shall be installed.

## 2.5 GENERAL INFORMATION

- 2.5.1 In order to complete this functional test it is not required to install upper stack assembly to portable exhauster. It also is not necessary to fill seal pot with water.
- 2.5.2 The 1000 cfm portable exhauster systems are interlocked to guard against malfunction. The operational safeguards and the control ranges are listed below.

### INTERLOCKS ASSOCIATED WITH THE 1000 CFM PORTABLE EXHAUSTERS

EQUIPMENT	INTERLOCK ACTUATION POINT	ACTUATION RESULT
GLYCOL HEATER	> 200°F AIR TEMP	HEATER SHUTS DOWN
GLYCOL HEATER	< 50% GLYCOL LEVEL	HEATER SHUTS DOWN
GLYCOL PUMP	< 50% GLYCOL LEVEL	PUMP SHUTS DOWN
INLET PLENUM	PRESSURE > -3.5 inWG	EXHAUSTER SHUTS DOWN
HEPA FILTER # 1	DP < .1 inWG FOR 10 SEC	EXHAUSTER SHUTS DOWN
HEPA FILTER # 1	DP > 5.4 inWG	EXHAUSTER SHUTS DOWN
HEPA FILTER # 2	DP < .1 inWG FOR 10 SEC	EXHAUSTER SHUTS DOWN
HEPA FILTER # 2	DP > 3.7 inWG	EXHAUSTER SHUTS DOWN
HEPA FILTER # 1&2	DP < .1 inWG FOR 10 SEC	EXHAUSTER SHUTS DOWN
HEPA FILTER # 1&2	DP > 5.4 inWG	EXHAUSTER SHUTS DOWN
STACK FLOW	< 470 cfm FOR 20 SEC	EXHAUSTER SHUTS DOWN
STACK FLOW	< 600 cfm	EXHAUSTER SHUTS DOWN
SEAL POT LEVEL	< 30% VOLUME	EXHAUSTER SHUTS DOWN
SEAL POT LEVEL	< 80% VOLUME	EXHAUSTER SHUTS DOWN

- 2.5.3 The glycol heater is equipped with an adjustable thermostat that keeps the heater unit ON to decrease the relative humidity of the flow from 100% to 70%.
- 2.5.4 Figure-1 is an illustration of the exhauster component

arrangement.

2.5.5

At the conclusion of testing prepare exhauster for storage per Section 2.0 "Preparation For Storage" of main document.

### 3.0 FUNCTIONAL TEST

#### 3.1 STARTUP EXHAUSTER

- 3.1.1 **VERIFY/INSTALL** the following filters:
- Prefilter
  - First and Second Stage HEPA Filters
  - Ruffing Filter over exhauster inlet.
- 3.1.2 **VERIFY/POSITION** the following Disconnect Switches are in the **OFF** position:
- VTP-DS-101 "480 VOLT MAIN DISCONNECT"
  - VTP-DS-102 "EXHAUST FAN MOTOR DISCONNECT"
  - VTP-DS-201 "GLYCOL HEATER DISCONNECT"
- 3.1.3 **VERIFY/POSITION** Mini Power Zone 480V MAIN "MPZ PRIMARY BREAKER" VTP-BRK-101 (located in VTP-DP-101 "MINI POWER ZONE") to **OFF**.
- 3.1.4 **VERIFY/POSITION** Mini Power Zone 240V SECONDARY MAIN "MPZ SECONDARY BREAKER" VTP-BRK-102 to **OFF**.

### 3.1 START-UP EXHAUSTER (Cont.)

3.1.5 **VERIFY/POSITION** the following MPZ 120V circuit breakers to **OFF** position:

CIRCUIT BREAKER NUMBER	DESCRIPTION	✓
MPZ-1	ACTION PAK RELAYS, POWER SUPPLIES, WILKERSON DISPLAY METERS	
MPZ-2	GLYCOL PUMP, SEAL POT PUMP, SHUNT TRIP, PILOT LIGHTS, ALARM BEACON	
MPZ-3	HEAT TRACE, GLYCOL CONTACTOR, HEAT TRACE LIGHT	
MPZ-4	CABINET HEATERS AND FANS	
MPZ-5	CONVENIENCE RECEPTACLE	
MPZ-6	GEMS "GFE" (SPARE)	N/A
MPZ-7	AMS-4 "GFE" (SPARE)	N/A
MPZ-8	FLAMMABLE GAS MONITOR (SPARE)	N/A
MPZ-9	(SPARE)	N/A
MPZ-10	(SPARE)	N/A

3.1.6 **CONNECT** portable exhauster to 480 VAC, 3 PH, 3 W power source.

3.1.7 **POSITION** the following Disconnect Switches to the **ON**:

- VTP-DS-101 "480 VOLT MAIN DISCONNECT"
- VTP-DS-102 "EXHAUST FAN MOTOR DISCONNECT"
- VTP-DS-201 "GLYCOL HEATER DISCONNECT"



### 3.1 START-UP EXHAUSTER (Cont.)

#### **WARNING**

Energized circuits and leads are contained inside the cabinet. Comply with HNF-PRO-088, "Electrical Work Safety".

- 3.1.8           **POSITION** Mini Power Zone 480V MAIN "MPZ PRIMARY BREAKER" VTP-BRK-101 to **ON**.
- 3.1.9           **POSITION** Mini Power Zone 240V SECONDARY MAIN "MPZ SECONDARY BREAKER" VTP-BRK-102 to **ON**.
- 3.1.10           **POSITION** the following MPZ 120V circuit breakers to **ON**:

CIRCUIT BREAKER NUMBER	DESCRIPTION	✓
MPZ-1	ACTION PAK RELAYS, POWER SUPPLIES, WILKERSON DISPLAY METERS	
MPZ-2	GLYCOL PUMP, SEAL POT PUMP, SHUNT TRIP, PILOT LIGHTS, ALARM BEACON	
MPZ-3	HEAT TRACE, GLYCOL CONTACTOR, HEAT TRACE LIGHT	
MPZ-4	CABINET HEATERS AND FANS	
MPZ-5	CONVENIENCE RECEPTACLE	

### 3.1 START-UP EXHAUSTER (Cont.)

3.1.11 **VERIFY** the following indicating lights located at VTP-CP-105 "CONTROL CABINET" are **ILLUMINATED**:

- Green "OFF" indicating light
- Wilkerson Indicators

3.1.12 **VERIFY/OPEN** the following butterfly valves:

- VTP-V-135 "HIGH ISOLATION VALVE MAIN AIRSTREAM"
- VTP-V-136 "LOW ISOLATION VALVE MAIN AIRSTREAM"

3.1.13 **OPEN** the High and Low valves **AND CLOSE** Equalizing valve on each three valve manifold for the following DPTs:

DPT	Valve # HI	Open (✓)	Valve # LO	Open (✓)	Valve # EQUAL	Close d (✓)
PDT-170 (PLENUM)	V-101		V-102		V-103	
PDT-178 (PREFILTER)	V-140		V-141		V-142	
PDT-177 (HEAT/DEMIST)	V-137		V-138		V-139	
PDT-180 (HEPA FLTR #1)	V-143		V-144		V-145	
PDT-181 (FILTER TRAIN)	V-146		V-147		V-148	
PDT-182 (HEPA FLTR #2)	V-149		V-150		V-151	
*FT-184 (STACK)	V-155		V-156		V-157	

Note: All valve and instrument numbers preceded with VTP-

\* If stack installed

3.1.14 **IF** upper stack is not installed **CONNECT** the Yokogawa BT-200 to the back terminals of the stack flow transmitter VTP-FT-184 per Vendor Information.

### 3.1 START-UP EXHAUSTER (Cont.)

3.1.15                    **VERIFY/POSITION** the following valves (located at "SEAL POT" VTP-SP-001) as follows:

Valve Number	Description	Position	✓
VTP-V-160	SEAL POT DRAIN VALVE	CLOSED	
VTP-V-161	SEAL POT GRAVITY DRAIN VALVE	CLOSED	
VTP-V-162	SEAL POT FILL PORT VALVE	CLOSED	
VTP-V-163	SEAL POT PUMP DRAIN VALVE	CLOSED	
VTP-V-164	SEAL POT PUMP VALVE	CLOSED	
VTP-V-165	SEAL POT PUMP OVERFLOW VALVE	CLOSED	
VTP-V-166	SEAL POT PUMP DRAIN VALVE	CLOSED	

3.1.16                    **VERIFY/CLOSE** VTP-V-158 "FAN ISOLATION VALVE".

3.1.17                    **FORCE** seal pot LO Level Alarm signal above 30% using laptop computer.

3.1.18                    **IF** the glycol system is charged perform the following **OR** go to step 3.1.21 if system uncharged.

### 3.1 START-UP EXHAUSTER (Cont.)

## WARNING

Glycol Tank, exposed piping and valves may be hot (140°F to 200°F)

3.1.19 **VERIFY/POSITION** the following valves:

VALVE NUMBER	DESCRIPTION	POSITION	✓
VTP-V-201	HIGH ISOLATION VALVE GLYCOL PUMP	OPEN	
VTP-V-202	LOW ISOLATION VALVE GLYCOL PUMP	OPEN	
VTP-V-203	GLYCOL TANK ISOLATION VALVE	OPEN	
VTP-V-204	HEATER COIL ISOLATION VALVE	OPEN	
VTP-V-205	GLYCOL SYSTEM DRAIN VALVE	CLOSED	

3.1.20 **IF** VTP-LI-205, "GLYCOL LEVEL" is  $\leq$  50% Volume, **FILL** the "GLYCOL EXPANSION TANK" VTP-TK-001 with 50% glycol and 50% water mixture per Section 3.4.

**NOTE -** The exhauster system must operate for a minimum of 15 minutes if not using glycol system. If using glycol system the exhauster must operate for a minimum of 30 minutes.

3.1.21 **START** the "EXHAUST FAN" VTP-EF-001 by **PERFORMING** the following:

3.1.21.1 **POSITION** "FAN CONTROL" VTP-HS-103 to "**ENABLE**" (located on the door of "CONTROL CABINET" VTP-CP-105).

3.1.21.2 **PRESS** "STOP PUSH BUTTON" VTP-PB-102 to reset the variable frequency drive program and allow restart of fan.

3.1.21.3 If stack is not installed **INPUT** VTP-FT-184 flow

transmitter signal on the Yokogawa BT-200 transmitter configurer.

### 3.1 START-UP EXHAUSTER (Cont.)

- 3.1.21.4     **PRESS** "START PUSH BUTTON" VTP-PB-101 (located on the door of the "CONTROL CABINET" VTP-CP-105).
- 3.1.21.5     **ENSURE** Red "RUN" light is ILLUMINATED.
- NOTE         -     Failure to maintain the corresponding HEPA filter Differential Pressures within the associated Differential Pressure range and appropriate exhaust fan flows, may result in a VTP-EF-001 "EXHAUST FAN" SHUTDOWN.
- NOTE         -     The Exhauster Fan will NOT stay "ON" if any of the following conditions exist:
- HEPA FILTER #1 HIGH HIGH OR LOW DIFFERENTIAL PRESSURE (as indicated on VTP-PI-180)
  - HEPA FILTER #2 HIGH HIGH OR LOW DIFFERENTIAL PRESSURE (as indicated on VTP-PI-182)
  - FILTER TRAIN HIGH HIGH OR LOW DIFFERENTIAL PRESSURE (as indicated on VTP-PI-181)
- 3.1.22         **RECORD** the date, time, and additional startup data as required on Portable 1000 CFM EXHAUSTER DATA SHEET.
- 3.1.23         **IF** glycol system is charged perform the following steps **OR** skip to section 3.2.3.
- 3.1.24         **START** the exhauster glycol pump and heater by **PERFORMING** the following:
- 3.1.24.1       **POSITION** "GLYCOL PUMP" Control Switch VTP-HS-102 to ON.

### 3.1 START-UP EXHAUSTER (Cont.)

#### **CAUTION**

Potential exposure to 480 VAC. Comply with HNF-PRO-088, "Electrical Work Safety".

- 3.1.25 **ADJUST** glycol electric heater thermostat to maintain the heater outlet temperature 20°F higher than heater inlet temperature.
- 3.1.26 **RECORD** all additional system startup data as required on PORTABLE 1000 CFM EXHAUSTER DATA SHEET.

## 3.2 OPERATE EXHAUSTER

- 3.2.1 **MAINTAIN** exhauster operation such that heater outlet temperature is at least 20°F higher than heater inlet temperature, but do not exceed 200°F on a continuing basis.
- 3.2.2 **IF** "GLYCOL EXPANSION TANK" level is  $\leq 50\%$ , **FILL** with 50% water and 50% Propylene Glycol per Section 3.4.
- 3.2.3 **RECORD** data at least once a day while the exhauster is running on PORTABLE 1000 CFM EXHAUSTER DATA SHEET.

### 3.3 SHUTDOWN OF EXHAUSTER

3.3.1 **SHUT DOWN** the "EXHAUST FAN" VTP-EF-001, as follows:

3.3.1.1 **PRESS** "STOP PUSH BUTTON" VTP-PB-102.

3.3.1.2 **POSITION** "FAN CONTROL" VTP-HS-103 to OFF.

3.3.1.3 **RECORD** the time and reason for shutdown on PORTABLE 1000 CFM EXHAUSTER DATA SHEET.

3.3.2 **IF** an EMERGENCY condition exists, **SHUT DOWN** the "EXHAUST FAN" VTP-EF-001 as follows:

3.3.2.1 **PRESS** red "PUSH BUTTON EMERGENCY STOP" VTP-PB-103 (*located on door of "480 VOLT MAIN DISCONNECT" VTP-DS-101*).



### 3.3 SHUTDOWN OF EXHAUSTER (Cont.)

3.3.3 **POSITION** the following 120V circuit breakers to OFF:

CIRCUIT BREAKER NUMBER	DESCRIPTION	✓
MPZ-1	ACTION PAK RELAYS, POWER SUPPLIES, WILKERSON DISPLAY METERS	
MPZ-2	GLYCOL PUMP, SEAL POT PUMP, SHUNT TRIP, PILOT LIGHTS, ALARM BEACON	
MPZ-3	HEAT TRACE, GLYCOL CONTACTOR, HEAT TRACE LIGHT	
MPZ-4	CABINET HEATERS AND FANS	
MPZ-5	CONVENIENCE RECEPTICAL	

3.3.4 **REMOVE** the seal pot force.

3.3.5 If required **DISCONNECT** the Yokogawa BT-200 from the stack flow transmitter VTP-FT-184.

3.3.6 If required **REPLACE** the Yokogawa BT-200 backing to flow transmitter VTP-FT-184.

3.3.7 **POSITION** Mini Power Zone 240V SECONDARY MAIN "MPZ SECONDARY BREAKER" VTP-BRK-102 to **OFF**.

3.3.8 **POSITION** Mini Power Zone 480V MAIN "MPZ PRIMARY BREAKER" VTP-BRK-101 to **OFF**.

### 3.3 SHUTDOWN OF EXHAUSTER (Cont.)

- 3.3.9        **POSITION** "GLYCOL HEATER DISCONNECT" VTP-DS-201 to OFF.
- 3.3.10      **POSITION** "EXHAUST FAN MOTOR DISCONNECT" VTP-DS-102 to OFF.
- 3.3.11      **POSITION** "480 VOLT MAIN DISCONNECT" VTP-DS-101 OFF.
- 3.3.12      **OPEN** the High, Low and Equalizing valves on each three valve manifold for the following DPTs:

DPT	Valve # HI	Open (✓)	Valve # LO	Open (✓)	Valve # EQUAL	Open (✓)
PDT-170 (PLENUM)	V-101		V-102		V-103	
PDT-178 (PREFILTER)	V-140		V-141		V-142	
PDT-177 (HEAT/DEMIST)	V-137		V-138		V-139	
PDT-180 (HEPA FLTR #1)	V-143		V-144		V-145	
PDT-181 (FILTER TRAIN)	V-146		V-147		V-148	
PDT-182 (HEPA FLTR #2)	V-149		V-150		V-151	
*FT-184 (STACK)	V-155		V-156		V-157	

Note: All valve and instrument numbers preceded with VTP-

\* If stack installed

- 3.3.13        **REMOVE** the following filters and store per section 2.3 of main document:

- Prefilter
- First and Second Stage HEPA Filters
- Ruffing Filter over exhauster inlet.

### 3.4 FILL GLYCOL EXPANSION TANK

**CAUTION:** Rubber or neoprene gloves must be worn when handling glycol solutions.

- 3.4.1 **LIFT** fill/vent cap on "GLYCOL EXPANSION TANK" VTP-TK-001.
- 3.4.2 **ADD** 50% water and 50% propylene glycol to the "GLYCOL EXPANSION TANK" until VTP-LI-205 "GLYCOL LEVEL" reads 60% of Volume.
- 3.4.3 **CLOSE** fill/vent cap for the "GLYCOL EXPANSION TANK" VTP-TK-001.
- 3.4.4 **RECORD** the date and time that the "GLYCOL EXPANSION TANK" was filled on the PORTABLE 1000 CFM EXHAUSTER DATA SHEET.

HNF-2027  
Rev. 0

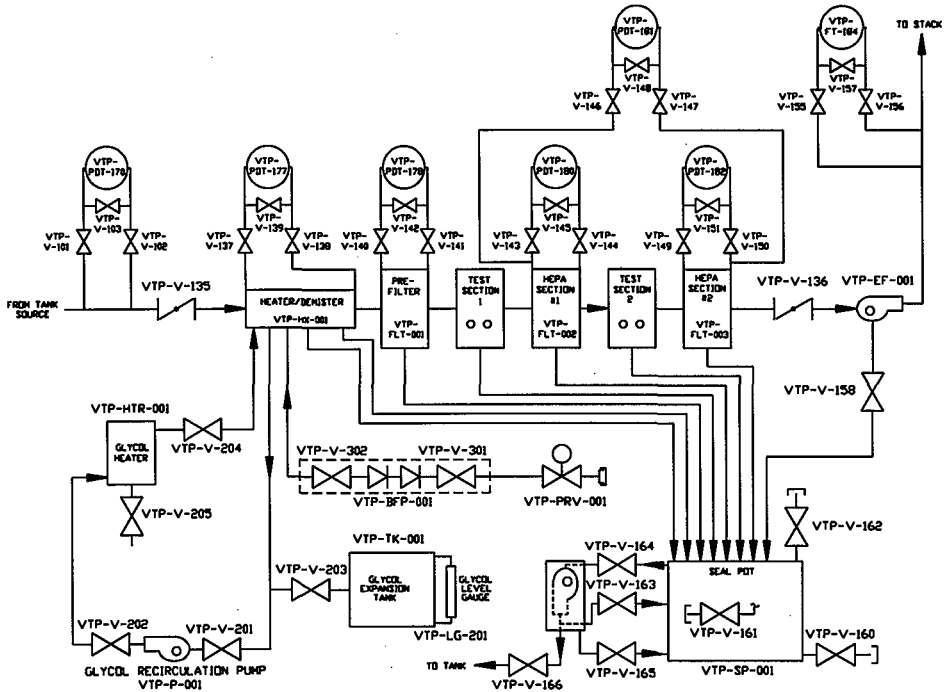

FIGURE 1 - EXHAUSTER FLOW

**PORTABLE 1000 CFM EXHAUSTER DATA SHEET**

INSTRUMENT	UNITS	NORMAL RANGE	READING
VTP-TI-176 (VENT SKID INLET TEMP.)	°F	100 °F to 140 °F	
VTP-TI-179 (HEPA #1 INLET TEMP)	°F	160 °F to 180 °F	
VTP-TI-183 (HEPA #2 OUTLET TEMP)	°F	160 °F to 180 °F	
VTP-PDI-177 (DEMISTER/HEATER DP)	inWG	0.01 to 2.0	
VTP-PDI-178 (PRE-FILTER DP)	inWG	0.10 to 1.0	
VTP-PDI-180 (HEPA FILTER #1 DP)	inWG	0.10 to 4.5	
VTP-PDI-182 (HEPA FILTER #2 DP)	inWG	0.10 to 3.2	
VTP-PDI-181 (HEPA FILTER #1 & #2)	inWG	0.10 to 4.5	
VTP-LI-185 (SEAL POT LIQUID LEVEL)	% Volume	30% to 80%	N/A
VTP-LI-205 (GLYCOL LIQUID LEVEL)	% Volume	> 50%	
VTP-FT-184 (STACK FLOW)	CFM	470 to 1000 CFM	

GLYCOL TANK FILLED \_\_\_\_\_  
SIGNATURE DATE/TIME

START-UP \_\_\_\_\_  
SIGNATURE DATE/TIME

SHUTDOWN \_\_\_\_\_  
SIGNATURE DATE/TIME

REASON FOR SHUTDOWN \_\_\_\_\_