



## TEST FACILITY TIMO FOR TESTING THE ITER MODEL CRYOPUMP

H. HAAS<sup>(1)</sup>, CHR. DAY<sup>(1)</sup>, A. MACK<sup>(1)</sup>, S. METHE<sup>(1)</sup>, J.C BOISSIN<sup>(2)</sup>,  
P. SCHUMMER<sup>(2)</sup>, D. K. MURDOCH<sup>(3)</sup>

(1) Forschungszentrum Karlsruhe, Hauptabteilung Ingenieurtechnik, P.O. Box 3640,  
D-76021 Karlsruhe, Germany.

(2) L'Air Liquide, Division des Techniques Avancées, B.P. 15, F-38360 Sassenage, France.

(3) NET Team, Max Planck Inst. für Plasmaphysik, Boltzmannstr. 2, D-85748 Garching,  
Germany

### Abstract

Within the framework of the European Fusion Technology Programme, FZK is involved in the research and development process for a vacuum pump system of a future fusion reactor. As a result of these activities, the concept and the necessary requirements for the primary vacuum system of the ITER fusion reactor were defined. Continuing that development process, FZK has been preparing the test facility TIMO (Test facility for ITER Model pump) since 1996. This test facility provides for testing a cryopump all needed infrastructure as for example a process gas supply including a metering system, a test vessel, the cryogenic supply for the different temperature levels and a gas analysing system. For manufacturing the ITER model pump an order was given to the company L' Air Liquide in the form of a NET contract.

## 1. DESCRIPTION OF THE ITER CONCEPT FOR THE PRIMARY VACUUM PUMP SYSTEM

The primary vacuum pump system includes in total sixteen identical regenerating cryosorption pumps. Each of these pumps with 1600 mm length and 1500 mm diameter will be installed at the outboard of a divertor pump duct located at the bottom of the plasma chamber of the ITER fusion reactor. The pumping process is based on cryosorption of hydrogen isotopes and helium on 5 K cooled panels with a total pumping area of 8 m<sup>2</sup> per pump which are coated with activated charcoal. The impurities of the ITER exhaust gas will be condensed on the 80 K baffles as well as on the 5 K panels [1]. The system of 16 vacuum pumps will provide the required vacuum condition inside the ITER plasma chamber during all foreseen operation phases, as for example plasma operation or pump down. Due to the maximum allowable tritium inventory inside all the vacuum pumps, the pumping system must work in a staggered mode [2]. This means that during the different pumping modes some of the pumps will be regenerated at a temperature of about 80 K or reactivated at a temperature of 300 K depending on the reached pump loading. A normal 1200 s pumping cycle for one pump includes a 900 s sequence for the pumping mode and a 300 s duration for the regeneration mode. During the regeneration several submodes like heating up to 80 K, thermal gas release, pump out and the cooling down of the sorption panels to 5 K must be run. The regenerated gas will be pumped out by a roughing pump station. The foreseen ITER vacuum pumping system must fulfil requirements such as the pumping speed of 1000 m<sup>3</sup>/s at the operation pressure of 2.5 10<sup>-1</sup> Pa.

## 2. DESCRIPTION OF THE TIMO TEST FACILITY

To demonstrate the feasibility of this pump concept for the ITER reactor, the test facility TIMO has been under construction at FZK since 1996. The intention of this facility is to investigate the pumping performance of a cryosorption pump within all ITER relevant pumping modes, simulating ITER conditions of gas temperature, pressure, gas composition, etc. but not magnetic fields, neutron radiation and tritium exposure. In the following sections the different components of the test facility TIMO will be described.

### 2.1. Test vessel and the model pump

Within the cylindrical test vessel with a diameter of 1800 mm and a length of 4300 mm the test pump will be installed. The test vessel is built in accordance with the PNEUROOP standard for vacuum pump testing. For optimisation of the vacuum conditions inside the vessel, the inner surfaces were

electropolished. Due to safety reasons caused by the handling of hydrogens, the vessel is constructed to withstand an overpressure of 0.7 MPa. To simulate the divertor duct temperature conditions with a max. temperature of 475 K, the test vessel was equipped with a heating system. For the conditioning of the test vessel with a total volume of 10.4 m<sup>3</sup> and for regeneration of the model pump two roughing vacuum stations were installed. The installation of the piping system between the vessel and the metering system for the supply of the process gas and of the exhaust lines including the safety devices was completed.

The model pump is a cryopump with a cylindrical housing of 1200 mm in diameter and a length of 1360 mm (see Fig. 1). In the inner system the pump contains a set of laterally arranged cryopanel. These cryopanel are protected against thermal radiation by a 80 K louvre baffle and a 80 K shield system. The total pumping surface of the cryosorption panels installed in the model pump is reduced by a factor of 1:2 compared to the conceptual dimensions of the ITER pump. This yields a total pumping area of 4 m<sup>2</sup> for the 16 cryopanel installed in the model pump. Each of the cryopanel (840 x 160 mm<sup>2</sup>) is manufactured in quilted design and coated on both sides with activated charcoal.

For controlling the pressure inside the pump a pneumatically driven valve disk with a diameter of 700 mm and a stroke of 400 mm was installed at the pump inlet port. With this inlet valve the gas throughput during the pumping mode can be controlled by accurate positioning ( $\pm 1$  mm) of the valve disk, or as a second function the cryopump can be closed during the regeneration and the stand-by mode.

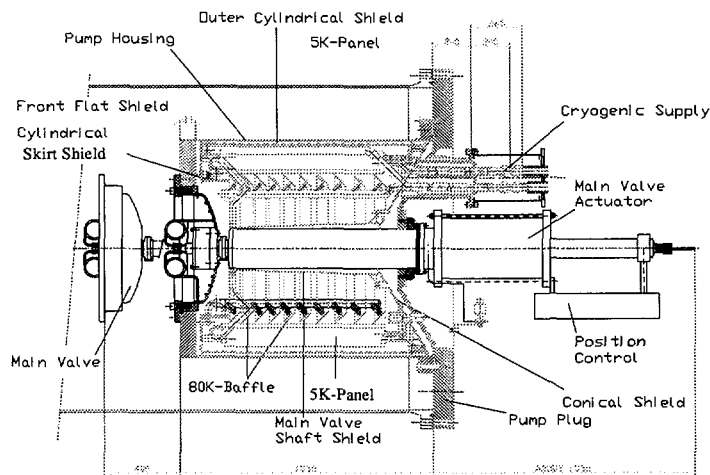

FIG. 1. Sketch of the ITER model pump

## 2.2. Cryogenic supply

For the cooling of the test pump 80 K gaseous helium and supercritical helium at 4.5 K are required. The supercritical helium flow at a pressure of 0.4 MPa will be supplied by a 600 W LINDE refrigerator via a control cryostat. Within the cooling loop of this control cryostat with a total inventory of 2600 l liquid helium a blower can circulate a mass flow of max. 250 g/s supercritical helium during the pumping operation and stand-by mode. To provide enough supercritical helium gas at 5 K at the beginning of the cooling phase an additional helium buffer is placed inside the liquid helium bath. Within this buffer tank with a volume of 250 l gaseous helium at 4.4 K and a pressure of 1.9 MPa can be stored.

For cooling the 80 K components inside the test pump such as shields and the baffles, a 80 K system has been procured (see Fig. 2).

This 80 K system includes the following components:

- A heat exchanger designed as liquid nitrogen bath and a system of spiral tubes for a max. heat exchanger power of 30 kW between the boiling nitrogen and the circulated gaseous helium,
- a cold blower from the Barber Nichols Company to circulate a max. mass flow of 200 g/s gaseous helium at 80 K,

- the cryogenic lines for the gaseous helium flow at 80 K and 1.5 MPa operating pressure,
- the cryogenic lines for liquid nitrogen supply and the gaseous nitrogen exhaust and
- the instrumentation of the facility including the measuring technique and a PLC for controlling the 80 K facility.

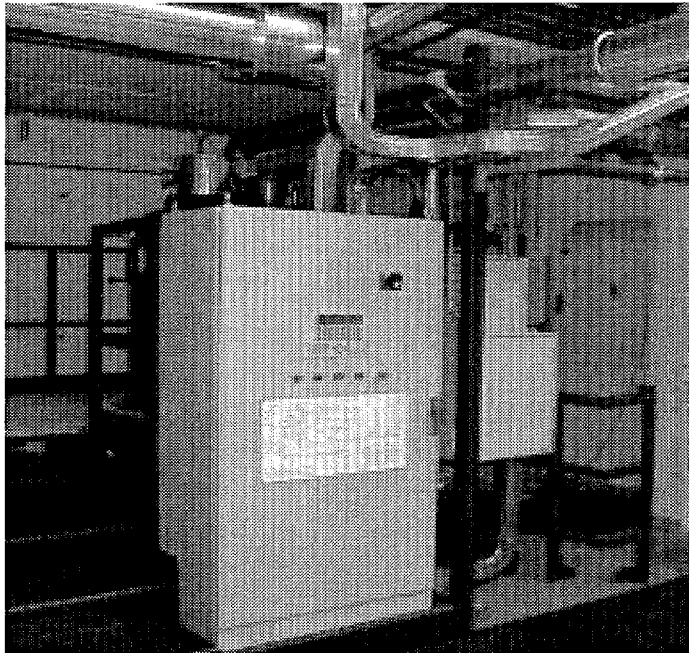

FIG. 2. The 80 K facility for the TIMO test facility

For the manufacturing of this 80 K facility an order was placed to the company Criotec Impianti from Turin (Italy). After the delivery of the 80 K facility, the piping system as well as the PLC system were installed into the infrastructure of the TIMO facility.

To heat up the 5 K cryosorption panels during the regeneration or the reactivation mode, 300 K gaseous helium with a max. mass flow of 50 g/s can be used which is supplied from the compressor of the LINDE refrigerator.

All the gaseous supply and return flows at the temperature levels of 5 K , 80 K and 300 K for the several operation modes of the test pump will be controlled by a cold valve box. Between this valve box and the test pump a main transfer line including the different supply lines and return lines will be installed. The valve box as well as the main transfer line were designed and manufactured by L' Air Liquide. The main transfer line will be delivered together with the ITER model pump. The valve box was delivered in February 1998.

### 2.3. Process gas supply and metering system

For the process gas supply of the TIMO facility seven gas supply lines (ITER relevant process gas mixture, H<sub>2</sub>, D<sub>2</sub>, N<sub>2</sub>, Ar, He, Ne) were installed between the gas reservoir and the gas metering system. Three lines which are planned for the use during hydrogen operation have already been equipped with safety-relevant systems, such as explosion-proof control electronics and flow regulators. Four gas flow meters were installed for controlling the gas throughputs in a range between the  $1.7 \cdot 10^{-3}$  and 16.9 (Pa·m<sup>3</sup>/s).

### 2.4. Gas analysing system

To control and monitor the gas composition inside the test vessel a quadrupole gas mass spectrometer was procured by company BALZERS, Liechtenstein. With this mass spectrometer a standard mass range between 1-128 AMU can be measured. In addition to this normal analysing mode, a high-resolution operation over the mass range between 1-22 AMU is available [3]. In the high-resolution operation the separation of helium (4.0026 AMU) and deuterium (4.0282 AMU) is

possible. The gas analysing system is connected to the test vessel of the TIMO facility through two different gas inlet systems depending on the process pressure. During the tests with the ITER model pump the gas composition can be analysed for the pumping mode as well as for the regeneration mode. The gas analysing system is equipped with a pressure reduction system which ensures that the mixture composition obtained from the test vessel enters the analyser unchanged.

### 2.5. Data acquisition system and PLC system

During the tests a data acquisition system allows to perform measurement of up to 200 measuring points with a maximum acquisition frequency of 10 Hz. The processes and valve movements required during the pump tests will be controlled by means of the installed PLC system (Simatic S5-135U). In addition to this PLC system, a process visualization system (COROS-LSB) of the Siemens company was installed to facilitate control and operation of the TIMO facility.

## 3. OUTLOOK

The tests at the new facility will start with a model pump which will be delivered at the end of October 1998. Figure 3 shows the model pump after the assembling. After the delivery of the model pump, the installation work including the preparation of the valve box together with the main transfer line will be finished.

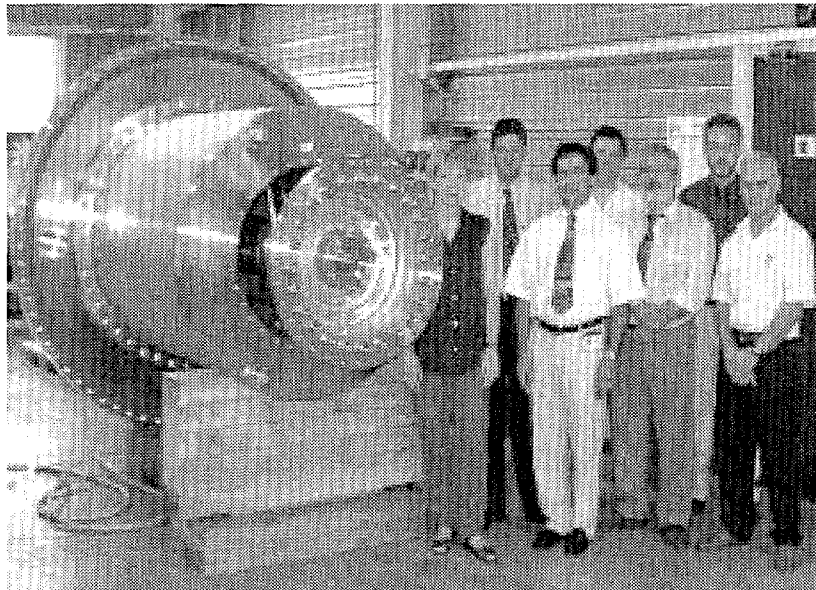

*FIG. 3 The ITER model pump after assembling*

Within the investigations, the pumping performance will be optimised and the consumption of cryogenics minimised to reduce the necessary cooling power.

- [1] BOISSIN, J. C., "ITER Model Cryopump Conceptual Design", Forschungszentrum Karlsruhe Contract 315/20 002 214 HIT (August 1995)
- [2] MURDOCH; D.K. et. al., "ITER primary pumping vacuum system concept development and testing programme", IAEA-CN-64/FP-5, Montreal (1996) 817 - 825.
- [3] DAY, Chr., "The use of a high-resolution quadrupolgas mass spectrometer system for selection of helium and deuterium", Vacuum **51/1** (1998) 21 - 30