

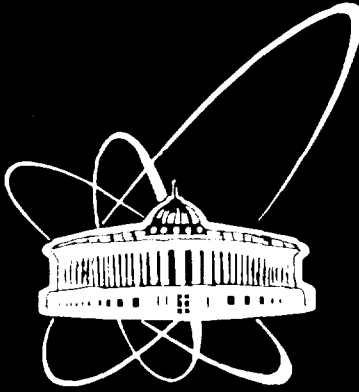

XJ0000023



СООБЩЕНИЯ
ОБЪЕДИНЕННОГО
ИНСТИТУТА
ЯДЕРНЫХ
ИССЛЕДОВАНИЙ

Дубна

E1-99-251

R.Brandt*

MEASUREMENTS OF NEUTRON YIELDS
AND RADIOACTIVE ISOTOPE TRANSMUTATION
IN COLLISIONS OF RELATIVISTIC IONS
WITH HEAVY NUCLEI

Report for the 85th Session of the JINR Scientific Council,
January 13–16, 1999, Dubna, Russia

*Kernchemie, FB 15, Philipps-Universität, Marburg, Germany

31-11

1999

Contents:

- 1.) Introduction: The „Rubbiatron“, its technical and social implication and the earlier Dubna work in this field.
- 2.) Our work [1-5]: Earlier experiments with a variety of relativistic ions and recent transmutation experiments on ^{129}J and ^{237}Np using relativistic protons.
- 3.) Some comments on related work of the Rubbia group at CERN.
- 4.) The connection of this work with earlier work on „anomalous“, alias „enhanced nuclear cross-sections“: short review of positive evidences for „anomalous“ and the recent understanding of the so-called Cu-block experiments within these phenomena.

1. Introduction: The „Rubbiatron“, its technical and social implications and the earlier Dubna work in this field

This article represents the work of the Dubna - Marburg - Jülich - Thessaloniki - Strasbourg - Sydney - Beijing - Shilong - Minsk - Los Alamos collaboration. However, the interpretations and extrapolations are not necessarily the agreed-upon understandings of the collaboration. The responsibility for this report rests upon the one who presented this talk at the Council Meeting. A more complete description of our recent work can be found in our publications [1-5].

Some years ago C. Rubbia introduced the concept of coupling a modern high intensity proton accelerator at relativistic energies to a subcritical nuclear power reactor. There is no doubt that his enthusiastic presentation initiated a world-wide discussion of this brilliant concept even when not all the ideas of this concept may have been entirely new. The essential components of this concept, called „energy amplifier“ or colloquially „Rubbiatron“, are shown in Fig. 1. One can assume that the readers are sufficiently familiar with this concept and it suffices to show schematically some of its consequences:

„subcritical nuclear reactors“	alias
„energy amplifiers“ (or Rubbiatrons)	alias
„accelerator coupled transmutation“	alias
„spallation neutron sources“	alias
(Synchrotron Radiation Sources)	

1. Nuclear electric power at 50% of the cost of present day NPP.

Gratis: no Chernobyl - risks, rather conventional technology.

2. Transmutation of the really dangerous rad-waste, i.p. plutonium and such minor actinides as Np, Am and Cm.

Gratis: mankind needs final depositories to be safe only for 600 years.

3. Thorium as a fuel-element will work easily, no Pu-production.

Gratis: Th/Pu - Mox fuel elements can transmute on-line Pu.

Note: Consequences (2) and (3) are the only rational methods to destroy completely the entire inventory of 1.300.000 kg plutonium on the Earth.

4. The proliferation risk is tremendous: using U-targets instead of Th-targets allows the easy and secret production of large amounts of Pu per annum, in particular, when one uses small relativistic accelerators, including electron accelerators simultaneously employed as synchrotron radiation sources.

Speaking pragmatically, as a rule-of-thumb, one can estimate the following transmutation rates in one year for a 1 mA proton accelerator at 1 GeV coupled to an „energy amplifier“ with an energy amplification $EA = 100$: either the production of 100 kg Pu or the destruction of 100 kg Pu, resp. Np.

From this one can conclude, that accelerators at GSI or CERN can produce about 10 kg Pu p.a., others correspondingly more or less.

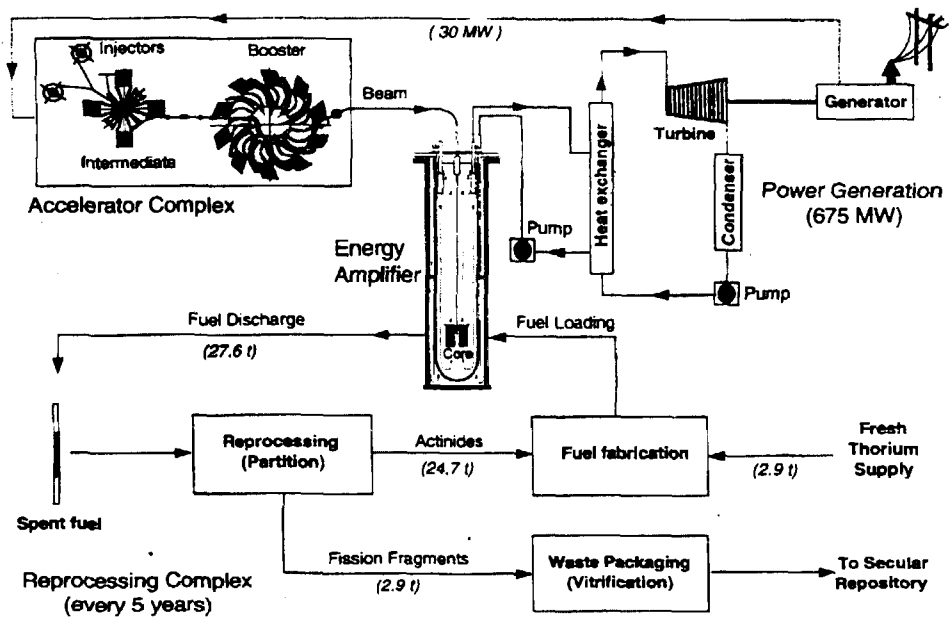

Fig. 1 The "Rubbiatron", a schematic representation [6] of a principle diagram of the Energy Amplifier Complex.

Projection: this rather new and fundamental technology may lead to:

- Presently, mankind obtains 17 % of its electric power from nuclear sources. This may increase by (20 - 40) %.
- In addition to present-day 430 NPP on the Earth, the construction and operation of > 1000 new NPP appear to be a realistic estimation.
- Many hundred thousand jobs for highly qualified women and men in the countries, where the society is willing to accept this modern technology.

CETERUM CENSEO: This entire „Rubbiatron“ technology, including all the above-mentioned accelerator devices, must come under IAEA (International Atomic Energy Agency), Vienna control, the faster the better.

Work along this line has a long history, possibly going back to the „Manhattan Project“ in the West and related projects on the European Continent during WW-II. However, it appears that this work was discontinued in the West around 1980 and such work was continued at the Laboratory of High Energies (LHE, JINR) with the aim of studying also rather fundamental problems in the interaction of relativistic ions with rather thick target systems. It suffices to give 2 examples here:

1. An essential result of the Tolstov group is shown in Fig. 2. A rather large Pb-target of 0.5-0.5-0.8 m dimensions was irradiated with all the 3.65 GeV/u ions available at the Synchrophasotron (LHE). Small approximately 1 g U-sensors were embedded into the Pb-target, and the ²³⁹Np formed during the irradiation was measured afterwards using standard gamma-counting and analyzing procedures. The results are expressed in terms of B-values defined as follows:

$$B = \frac{(\text{number of } ^{239}\text{Np formed})}{(1 \text{ g U-sample}) \cdot (1 \text{ primary ion})}$$

This term B is defined in a strictly empirical manner for a precise geometric set-up, a unique sensor and an energetically well-defined relativistic ion. Its value can also be calculated theoretically when the energy spectrum of secondary neutrons in this geometric position has been calculated and the corresponding excitation function for the (n,y) reaction is known. The results for the Tolstov experiment are shown in Fig. 2. As one can see, the B-values are both experimentally and theoretically over a range of $10^{-3} < B < 10^{-4}$ for practically all the used heavy ions and the agreement between experiment and theory is quite satisfactory, with one exception: the B-values for 44 GeV ¹²C are about (50 ±20)% larger experimentally than one can calculate theoretically. This result is interesting. However, it is still insignificant.

2. The next significant experiment has been carried out by R.Vasil'kov, again at the Synchrophasotron in Dubna. This team employed a typical Pb-target used in these studies, as indicated in Fig.3. Furthermore, they employed rather complex and modern neutron detection devices, and their results are also shown in Fig.3: The number of neutrons emitted from the Pb-target increase - to a first approximation - linearly with the total energy E of the incoming ion. The increase of neutrons decreases with respect to E/u for protons, deuterons and alphas when going from 1.5 GeV/u up to 3.7 GeV/u. This is well-known and in complete agreement with all established theories. However, for ¹²C one observes again an increase in neutrons produced with increasing E when going from 1.5 GeV/u up to 3.7 GeV/u. The authors [7] write that this is against all the known laws of physics. In other words, we observe again more neutrons at 44 GeV ¹²C than one can calculate, just as has been observed independently by Tolstov. From a fundamental logical point-of-view, this phenomenon obeys a „logic“ of $1 + 1 = 3$.

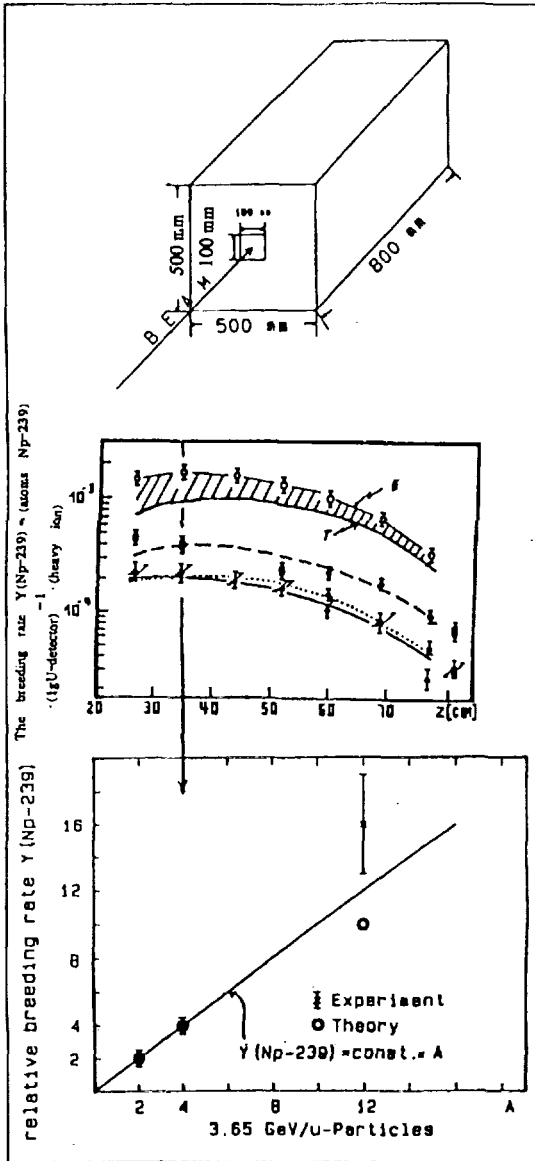

The very massive Pb-target ($0.5 \times 0.5 \times 0.8 \text{ m}^3$), irradiated with 3.65 GeV/u ions from the Synchro-phasotron, JINR, Dubna [6]

Results for the breeding of ^{239}Np in the very massive Pb-target (fig.1a), as determined along the central beam axis. Open circles: 3.65 GeV/u ^{12}C , closed circles: 3.65 GeV/u 4He , open triangle: 3.65 GeV/u 2H , closed triangles: 8 GeV 1H . For 4He , 2H and 1H , the calculations of Y agree with the experiment. For ^{12}C , the calculations (F) are below the experiments (E), as shown by the hatched area

More-than-calculated-breeding (possibility) of ^{239}Np as seen in Fig.1b. Here we show a «cut» along the line $Z = 35 \text{ cm}$

Fig.2 Layout of the Tolstov's experiment

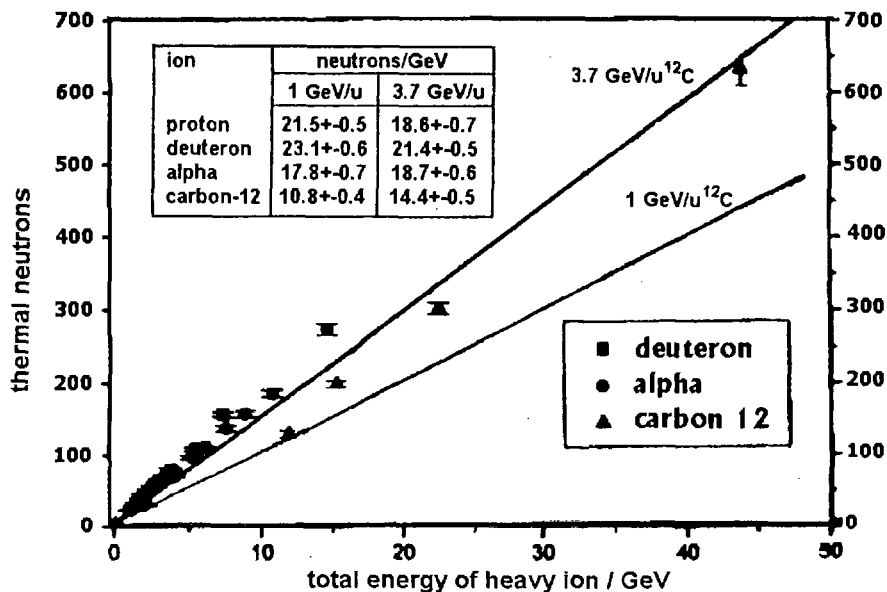
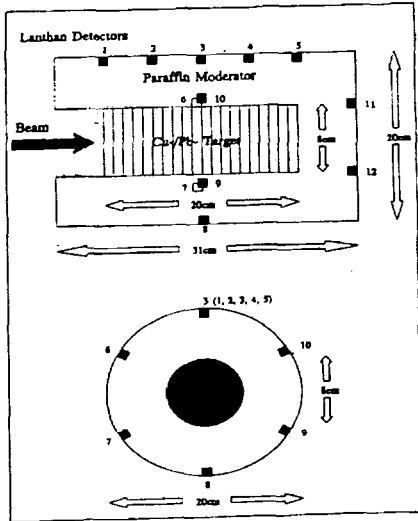

Fig. 3 The results of the experiment of the Vasil'kov group carried in Dubna [7]

Obviously, such an interesting effect with a statistical significance of about 5 standard deviations $(14.4 \pm 0.5) - (10.8 \pm 0.4) = 3.6 \pm 0.7$ should be studied further. Hopefully soon with an extracted beam of the Nuclotron.

2. Our work [1-5]: Earlier experiments with a variety of ions and recent transmutation studies with ^{129}J and ^{237}Np using relativistic protons

Our experimental set-up is shown in Fig.4. We used 20 disks of Cu or Pb, 8 cm Ø and 1 cm in thickness, surrounded with a 6 cm paraffin moderator. The La- and U-sensors, each about 1 g in thin plastic vials, are placed in small holes on the surface of the moderator, as indicated. Additionally, several sets of solid state nuclear track detectors (SSNTD's) are also installed in their positions, as shown in the original literature [2,3]. The beam profile monitored with a special SSNTD-foil from the Flerov-Laboratory (JINR) is shown in Fig. 5, indicating a well-focussed beam for 1.5 GeV protons on an U(Pb) target, measured with Lavsan SSNTD in contact with target (in tracks T / cm^2 : in front ($z=0$ cm), in the middle ($z=10$ cm) and at the end ($z=20$ cm) of the target).



After an exposure of the target system with relativistic ions and a typical ion fluence of 10^{12} up to 10^{13} ions, the induced activities in the La- and U- sensors were measured with standard gamma detection systems at the JINR (Dr. Adam's group) and analyzed, correspondingly. Some typical results are shown in Fig. 6 for ^{140}La . This is the (n,γ) reaction product formed from a stable target nuclide ^{139}La . As one can see, all projectile ions give approximately the same B-value distribution; again only 44 GeV ^{12}C produces rather large B-values. All the distributions have their maximum value approximately 10 cm downstream the beam entrance of the target. This has practical consequences for the construction of „energy amplifiers“ as the major part of the input ion energy is deposited into a relatively small volume - the size of an American football.

Fig. 4 The basic set-up for our experiments

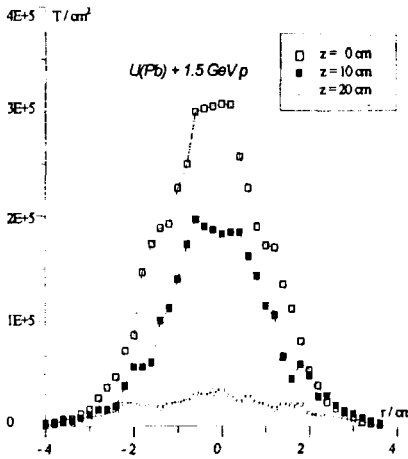

Fig. 5 The beam profile of the Synchrotron beam, measured with SSNTD at our target system

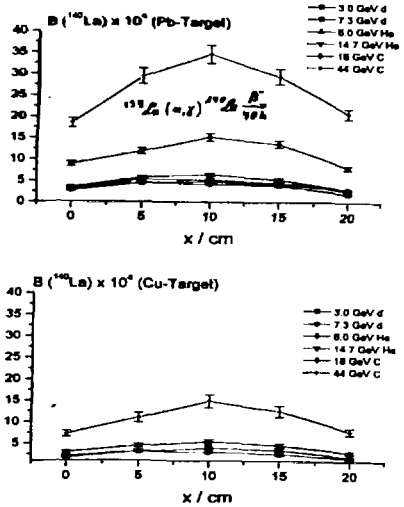

Fig. 6 Experimental B-values for ^{140}La

We observe only experimental B-values. However, the science community is interested in „neutron fluences per incoming ion“. This conversion is certainly a delicate issue as we have only one experimental number, and this number is the result of complex interactions as it is produced by neutrons within a broad energy spectrum and the (n,γ) reaction is strongly energy-dependent. Nevertheless, we have tried such a conversion, as described in detail in [2,3]. It is schematically shown below.

The B-value is an experimentally measured value. As an example, this holds for the reaction

$$^{139}\text{La} + n \rightarrow ^{140}\text{La} (\beta^-, 40 \text{ hours}) \rightarrow$$

$$B_{\text{exp}}(^{140}\text{La}) = \frac{\text{number of produced } ^{140}\text{La nuclei}}{(\text{1 primary ion}) \square (\text{1 g sample})}$$

This B-value allows a direct calculation of the transmutation capacity of the system exactly for this set-up and just in the given geometric target position.

On the other hand, this B-value is connected to the neutron fluence under the given conditions:

$$B_{\text{the}}(^{140}\text{La}) = N_T \cdot \int \Phi_n(E) \cdot \sigma_{n,\gamma}(E) dE.$$

Where N_T – density of the target atoms ($1/\text{cm}^3$).

When B_{exp} and $\sigma_{n,\gamma}(E)$ are known, we can estimate the neutron fluence $\Phi_n(E)$. Practically speaking, $B_{\text{exp}}(^{140}\text{La})$ is the sensor for thermal neutrons, and $\Phi_n(E)$ is then the thermal neutron fluence.

When the neutron fluence $\Phi_n(E)$ and $\sigma_{n,\gamma}(E)$ are both known theoretically, we can calculate a theoretically expected $B_{\text{the}}(^{140}\text{La})$.

We had two theoretical models at our disposal:

- 1.) The DCM-CEM code from Dubna, as used by A.N. Sosnin
- 2.) The LAHET code from Los Alamos, as used by B. Wilson

Now, we can compare the experimental values (B or Φ_n) with the calculated ones.

This procedure is rather well-defined, but its results will be taken with a certain caution, as both experiments and the experiment-to-neutron-number conversions are to an extent approximate. Taking this into account, we present in Fig. 7 the results for the experimental neutron number estimations as observed with our target system irradiated with protons, deuterons, alphas and ^{12}C -ions at the Synchrotron over the recent years (the corresponding paper is under preparation for publication - we also want to include future results at larger ion energies to be obtained soon from the Nuclotron in order to clarify the experimental situation even better. Fig. 7 shows the results for Cu- and Pb-target irradiation's grouped into four energy intervals:

- $N(\text{thermal})$ stands for low energy neutrons, as measured with the chemical sensor $\text{U} \rightarrow ^{239}\text{Np}$.
- $N(0.3\text{MeV} < E[n] < 3\text{MeV})$ stands for a SSNTD sensor (CR39), sensitive to those neutrons.
- $N(8\text{MeV} < E[n] < 15\text{MeV})$ stands for high energy neutrons, as measured with the chemical sensor $^{238}\text{U} \rightarrow ^{237}\text{U}$.
- $N(E[n] > 50\text{MeV})$ stands for very high energy neutrons, as measured with the SSNTD sensor (tracks due to $[\text{Au}+n \rightarrow \text{fission fragments}]$ on mica).

As one can see, we are observing in all the 8 reactions under study the same structural behavior for the number of emitted neutrons n_e :

- for protons, deuterons and alphas, one observes an increase in n_e between 0 and 1.5 GeV/u. At 3.7 GeV/u, we are having a leveling off in this increase.
- for ^{12}C , one observes an increase of neutron numbers n_e with E/u up to 3.7 GeV/u, sometimes even more than a linear increase with E/u - the effect already observed earlier by Vasil'kov [7].

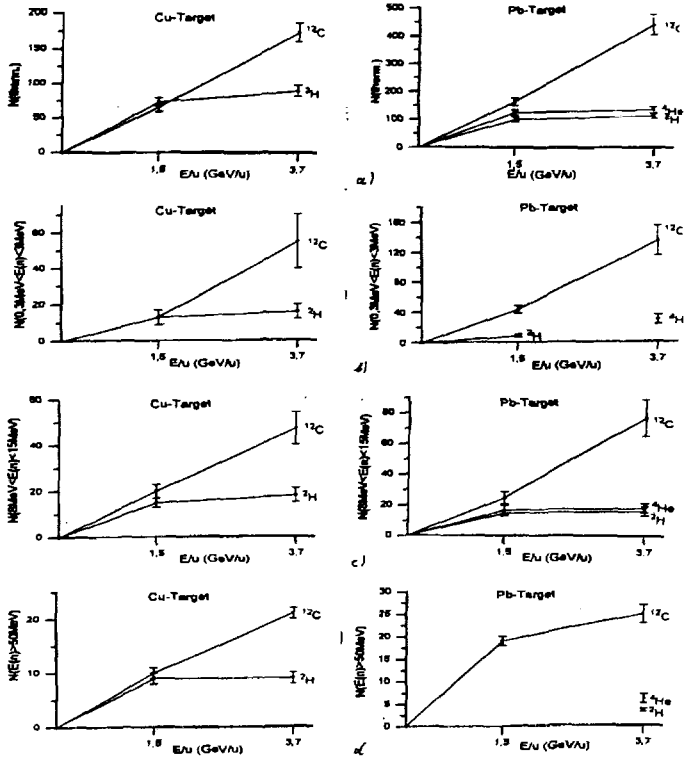

Fig. 7 Experimentally observed neutron numbers in different energy intervals using Cu- and Pb-targets irradiated at the Synchrophasotron

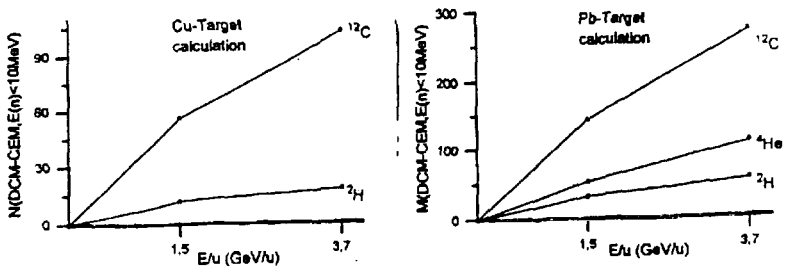

Fig. 8 Theoretical neutron numbers for the experiments shown in Fig. 7. It is interesting to note that theoretical estimations of the total numbers of secondary neutrons, as calculated with the Dubna DCM/CEM codes and shown in Fig. 8, predict the following properties:

- The increase of the total number of neutrons with energies below 10 MeV should be similar for protons, deuterons, alphas and ^{12}C with increasing specific energy E/u . This is at variance with our experimental findings as it holds only for p-, d- and α -beams.
- The total number of calculated neutrons is about a factor of 2 smaller as observed experimentally.

It is obvious, that these effects must be studied further, as mentioned beforehand.

Now, we describe our recent work on the transmutation of long-lived radwaste using relativistic protons [1].

The team placed radioactive ^{129}I and ^{237}Np samples on top of the target set-up, as shown in Fig. 9. In some experiments, we used a slightly modified target: the center of the target was composed of two natural uranium rods, 3.6cm \varnothing and 10.4cm in length, surrounded with Pb-rings and a paraffin moderator as shown in [6].

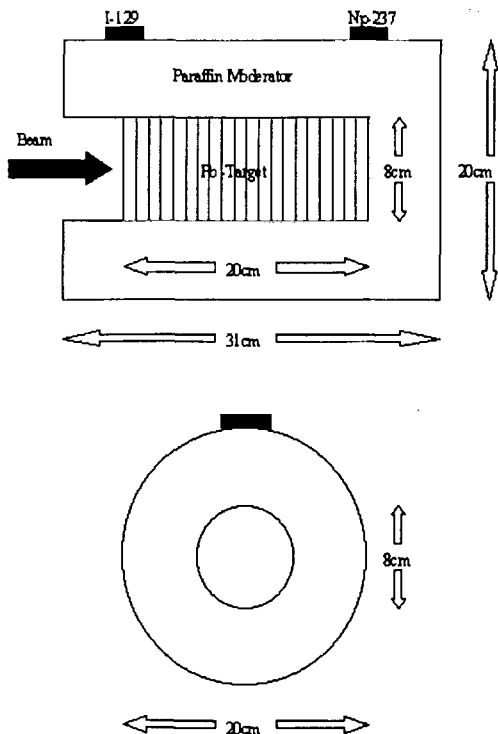

The radioactive targets, filled either with 0.5 g ^{129}I ($t_{1/2}=1.6 \cdot 10^7$ a) or with 0.7 g ^{237}Np ($t_{1/2}=2.1 \cdot 10^6$ a), were produced in Obninsk (see [1] for details) in the form shown in Fig.10a. They were irradiated either with secondary neutrons as shown in Fig. 9 or directly with a relativistic proton beam. After irradiation, the produced short-lived (and therefore *transmuted*) activity was studied with standard gamma counters. The resulting decay curves are shown in Fig. 10b. As shown in [2,3], the observed gamma spectra were very clean demonstrating a high purity of the radioactive samples produced at Obninsk.

Using the observed decay rates, it is easy to estimate directly the transmutation rates one can expect with a 10 mA proton accelerator at 1.5 GeV (Obviously, we must neglect here all technical details, such as heat effects and many other influences!):

Approximately 50% ^{237}Np and 4% ^{129}I can be transmuted per annum.

This corresponds to a thermal neutron flux of approximately $(2-4) \cdot 10^{14}$ n/s/cm².

Fig. 9. ^{129}I and ^{237}Np samples on top of the Pb - target

(a) A technical drawing of the targets produced in Obninsk.

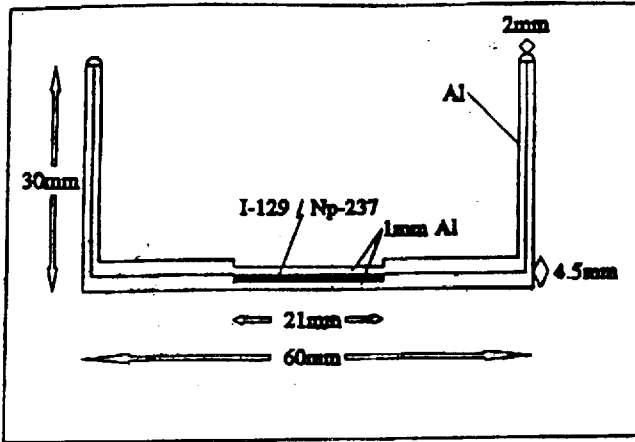

(b) The observed decay curves

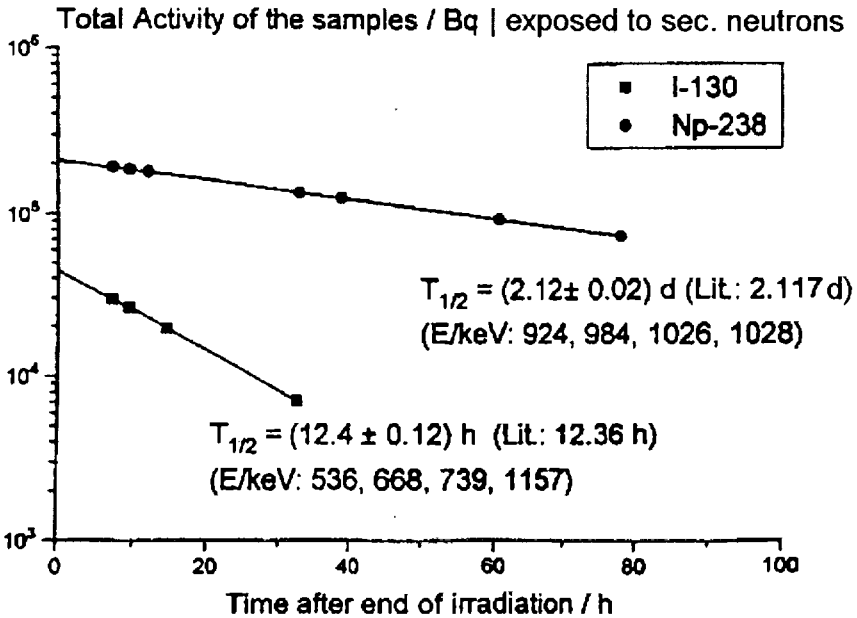

Fig.10 The radioactive ^{129}I and ^{237}Np samples.

As shown in [5], in the center of the 6 cm paraffin moderator the thermal neutron flux is about 5 times larger than that on the surface of the moderator indicating the fact that the above 1.5 GeV/10 mA proton accelerator gives thermal neutron fluxes in the order of very modern high-flux research reactors, for example the new reactor under construction in Munich (Germany).

However, we have not only been studying the transmutation rates for the two long-lived rad-waste nuclei, but we have also studied simultaneously the corresponding transmutation rates in the U- and La-sensors. The quantitative results are expressed as average B-values observed on the mantle-surface of the moderator (Tables 1 and 2).

Table 1. Experimental transmutation values of B_{exp} for the ^{129}I and ^{237}Np samples on the outer surface of the paraffin moderator for the Pb and U(Pb) target systems [3].

Proton energy	Pb-target $B_{exp} (^{130}\text{I})$	Pb-target $B_{exp} (^{236}\text{Np})$	U(Pb)-target $B_{exp} (^{130}\text{I})$	U(Pb)-target $B_{exp} (^{236}\text{Np})$
1.5 GeV	$(0.9 \pm 0.2)10^{-4}$	$(8.1 \pm 1.6)10^{-4}$	$(2.3 \pm 0.5)10^{-4}$	$(9.0 \pm 1.8)10^{-4}$
3.7 GeV*	$(3.1 \pm 0.5)10^{-4}$	$(44 \pm 7)10^{-4}$	-	-
7.4 GeV	$(4.0 \pm 0.8)10^{-4}$	$(41 \pm 9)10^{-4}$	$(14.7 \pm 3.0)10^{-4}$	$(50 \pm 10)10^{-4}$

* Ref. 2

Table 2. Average transmutation values of B_{exp} for the neutron-sensors on the outer surface of the paraffin moderator for the Pb and U(Pb) target systems (3).

Proton energy	Pb-target $B_{exp} (^{140}\text{La})$	Pb-target $B_{exp} (^{239}\text{Np})$	U(Pb)-target $B_{exp} (^{140}\text{La})$	U(Pb)-target $B_{exp} (^{239}\text{Np})$
1.5 GeV	$(1.7 \pm 0.4)10^{-4}$	$(0.75 \pm 0.15)10^{-4}$	$(3.1 \pm 0.7)10^{-4}$	$(1.4 \pm 0.3)10^{-4}$
3.7 GeV*	$(6.0 \pm 0.9)10^{-4}$	$(2.9 \pm 0.4)10^{-4}$	$(10.5 \pm 1.6)10^{-4}$	$(4.5 \pm 0.7)10^{-4}$
7.4 GeV	$(7.3 \pm 1.5)10^{-4}$	$(3.3 \pm 0.7)10^{-4}$	$(15.4 \pm 3.1)10^{-4}$	$(6.0 \pm 1.2)10^{-4}$

* Ref. 2

The observed B-values are in the same range as they have been found earlier by Tolstov. The uncertainties in our B-values are up to 20%. This is due to our radiochemical methods used to determine the total fluences ($\pm 10\%$) and occasional problems to measure proton fluences accurately at the Synchrophasotron. However, our intention is primarily to obtain experimental results for transmutations using relativistic accelerators. We have been unable to find other references in the field than those given here. Using the observed transmutation rates for $^{238}\text{U} \rightarrow ^{239}\text{Np} \rightarrow ^{239}\text{Pu}$, it is possible to estimate directly the Pu production rates available in all kinds of modern relativistic accelerators (see Introduction).

Now, we want to compare the experimental results with theoretical model estimations, as shown in Table 3. We have directly converted the experimental and theoretical B-values into neutron numbers. A detailed procedure and the limits of this procedure have been described elsewhere [2,3].

In Table 3, we find further evidence that the calculated neutron numbers are about a factor of two smaller than the experimental neutron numbers, in particular in the case of thermal neutrons (based on the B-values for ^{140}La). However, the statistical significance of this effect is only about 2 standard deviations in most cases. It is remarkable that the neutron numbers, calculated by two completely independent teams at the JINR in Dubna and at LANL in Los Alamos agree very well. From these studies we can conclude that the experiments must be continued, in particular an experimental precision shall become better than 20%.

Table 3. Some theoretical and experimental neutron fluences on the outer surface of the moderator normalized to one incident proton [6]

System	n/p		$\Phi_n(E)_{\text{theo}}$ all energies		$\Phi_n(E)_{\text{theo}}$ thermal ($<1\text{eV}$)		$\Phi_n(E)_{\text{exp}}$ thermal ($<1\text{eV}$)
1.5 GeV p + Pb	25.1	(1)	18.6	(1)	5.9	(1)	11 ± 3
			17.5	(2)	3.8	(2)	
1.5 GeV p + U(Pb)	43	(1)	38.2	(1)	13	(1)	21 ± 5
3.7 GeV p + Pb	43	(1)	34.2	(1)	10.6	(1)	38 ± 6
		(2)	34.3	(2)	7.7	(2)	
3.7 GeV p + U(Pb)	79	(1)	67.9	(1)	25	(1)	65 ± 10
7.4 GeV p + Pb	61.5	(1)	50.5	(1)	17	(1)	45 ± 9
7.4 GeV p + U(Pb)	140	(1)	117	(1)	41	(1)	96 ± 20

(1) calculated directly with the DCM-CEM code up to 10.4 MeV neutrons.

(2) calculated directly with the LAHET code up to maximum energy neutrons.

3. Some comments on related work of the Rubbia group at CERN

In this section, we compare the results of our experiments with those of the Rubbia group at CERN on their "energy amplifier", as published by Andriamonje et al. [8] and Calero et al. [9]. Their "energy amplifier" having linear dimensions of about 1 m contained so much natural uranium in normal water that the entire system had a neutron multiplication factor of $k = 0.895$. It was irradiated with relativistic protons between 0.6 GeV up to 2.7 GeV. Actually, the well-focussed proton beam is hitting an uranium target of similar dimensions as ours. The uranium is surrounded in its vicinity with water, the material with similar neutron moderating properties as our paraffin moderator. Therefore, it is not surprising to find similar transmutation rates in both experiments for uranium sensors in the same geometrical 10 cm position downstream the entrance of incident protons and then 10 cm off-center in the perpendicular direction. The experimental results for natural uranium are in units of (10^{-4}):

$$B(^{239}\text{Np}) = (5.7 \pm 0.5) \text{ at } 3.7 \text{ GeV, Dubna. } B(\text{fission}) = (7 \pm 1) \text{ at } 2.7 \text{ GeV, CERN}$$

$$B(^{239}\text{Np}) = (2.2 \pm 0.5) \text{ at } 1.5 \text{ GeV, Dubna. } B(\text{fission}) = (3.2 \pm 0.5) \text{ at } 1.5 \text{ GeV, CERN}$$

It is well-known that $B(^{239}\text{Np}) = (1.10 \pm 0.10) \cdot B(\text{fission})$ under the given experimental conditions [2,3]. The $B(\text{fission})$ values were given by Rubbia (CERN-seminar, 06.12.1994, private communication). The B values appear to be rather similar in both experiments despite some differences in the details of the experimental set-ups. Andriamonje et al [8] and Calero et al [9] published interpretations based on their models. They have no difficulties in understanding their experimental results. We have some problems in this respect:

1). Calero argues as follows: 1 GeV protons can liberate a maximum of 41 neutrons in an extended uranium target. This leads in a subcritical nuclear assembly with a neutron multiplication factor $k = (0.895 \pm 0.010)$ to a total maximum of 410 neutrons per incoming 1 GeV proton. They observe an energy amplification of 30. As the energy release per fission event is 200 MeV, one needs 150 neutrons to induce these 150 fission events giving an observed energy of 30 GeV. Here, Calero et al ends their elaborations.

We want to continue: When 200 MeV are released per fission event, only about 182 MeV are released as heat into the energy amplifier during an experiment of several hours. Neutrinos (12

MeV) and longer lived radioactive fission fragments do not heat the energy amplifier. (An exact calculation is omitted here.) This means we need about 165 neutrons for fission.

In addition, the relation between the fission rate and the neutron capture reaction in ^{238}U has already been given. The card-of-nuclides tells us that 20% more neutrons are needed to produce ^{236}U out of ^{235}U as compared to the fission rate in ^{235}U . Therefore, we need for neutron captures:

(181±18) neutrons for the production of ^{239}Pu , and

(33±3) neutrons for the production of ^{236}U .

Altogether, we have used up to 379 neutrons for interactions in actinides, leaving at a maximum of 31 ± 19 ($[8 \pm 5]\%$) of all neutrons for all the other neutron-loss reactions, such as absorption in protons (water), impurities, construction materials and leakage. Textbooks on radiochemistry teach us that one needs about 20% of all neutrons for all those reactions, besides actinide interactions in large nuclear power reactors. But an exact amount must be calculated in detail in each case. We have not carried out such a detailed neutron-balance calculation, nor did we consider experimental uncertainties in the CERN experiment systematically. But we feel that the above-mentioned 31 neutrons may not be enough.

2). The following equation relates the energy amplification, EA, the number of primary neutrons per incident proton, Y, the effective neutron multiplication, k, the number of neutrons per fission, $\nu=2.5$, and the fission energy, $E = 0.182$ GeV, to the incident proton energy, E_p (GeV), as shown by Sosnin et al [10]:

$$EA = \frac{Y \cdot k \cdot 0.182 \text{ GeV}}{2.5 \cdot (1 - k) \cdot E_p}$$

According to this equation, which is essentially based on the 1st law of thermodynamics, the CERN energy amplifier experiment requires the following value for the number of primary neutrons per incident proton at 1 GeV, $Y = (44.0 \pm 4.5)$. This value is possibly 10% larger than the maximum value of $Y = 41$, as given by Calero. (This difference is not statistically significant.) When one observes such a large value of Y, then one can calculate that the cost for an "effective" production of one neutron is $1000 \text{ MeV} / 44 \text{ n} = 23 \text{ MeV}$ per neutron. Recent calculations with the DCM/CEM code show that about 50% of the incident proton energy is used for proton ionizations and energy removal from our target system by hadrons escaping this system. This leads to an effective cost for the production of one neutron of 11.5 MeV. This value is rather low.

3). The most difficult problem for us is the difference between the observations of the Rubbia group with their relatively large values for Y and the experiments of Zucker et al [11], who measured the actual number of neutrons with proper electronic counters and observed $Y = (17.0 \pm 0.4)$ for the system (1 GeV p + Pb). The LAHET code calculations reproduce this value exactly. We know from our experiments and some other [2, 3] that exchanging a Pb target for an U target, the experimental B values (viz. the neutron number Y) increase by $(70 \pm 10)\%$. Consequently, the „Zucker“ experiment would give $Y = (30 + 1)$ for the system (1 GeV p + U). As compared to this value, the CERN value is $(47 \pm 15)\%$ larger. In our opinion, this discrepancy is statistically significant. If both experiments are correct, we may have rather a fundamental problem. We cannot offer a certain solution for this problem. However, one could mention possible at this Council Meeting that our publications [2,3] contain the conjecture that this discrepancy may be due to „enhanced nuclear cross sections“ of secondary neutrons at a certain short flight distance of about 15 cm in a moderator.

4). The CERN COURIER (April 1997, page 8) reported that the Rubbia group might have observed rather large energy amplifications, EA, over a range of $100 < EA < 150$. Now one should wait for an original publication where the parameters for this energy amplification will be given in detail, possibly within the context of the description of the TARC experiment with a large lead target (335 Mg) as indicated in the same announcement.

In summary, it is evident that we have not yet reached a complete understanding of the systems studied here. It may be advisable to try to understand these systems in a more complete

manner before one embarks in the large scale construction of operational accelerator driven transmutation complexes.

4. Connection of this work with earlier work on „anomalons“, alias “enhanced nuclear cross-sections“: a short review of positive evidences for „anomalons“ and a recent understanding of the so-called Cu-block experiments within these phenomena

The so-called anomalon-phenomenon is an old story. It started around 1955 and came to a climax around 1983. Then, its investigation stopped in the West around 1987 after the appearance of an article in France, which contained nothing about science [12]. In the East, this issue is also controversial. However, it remained a scientific controversy. Some scientists violently oppose the existence of these evasive particle-structures. The others stubbornly continue to publish what they consider positive evidence for anomalons. Such descriptions of positive evidences can be found in the „Proceedings of the International Conference on Nuclear Tracks in Solids“, as published by this team ever since the conference in Rome in 1985. The most recent paper [5] will be presented in the last Proceedings, to be published in “Radiation Measurements“ in 1999. The issues at stake are the questions:

- Can one observe in high energy physics particles a state (anomalon-state) where this state changes some central properties - say, interaction cross-section - during the first moments after its creation - say, a flight-path of typically 15 cm - without emitting any physically detectable particle?
- What about the „identity of a particle with itself“ when such states are indeed observable?
- Why are such „anomalon“ states observed under some very specific conditions and why are they unobserved at all under other - not too different - conditions ?
- Is the effect ($1+1=3$) observed by Vasil'kov (loc.cit.) and confirmed by this collaboration connected to such an anomalon phenomenon?
- Last but not least, what about the conservation laws when there are such phenomena as just described?

It is obvious, that these phenomena must arouse violent discussions in science - but what else is science all about ? It is the speaker's opinion that these phenomena are by no means absolutely certain; however, the contrary opinion is just as uncertain. Therefore, we should remember some published pro-anomalon evidences as compounded from [13] and shown in Fig. 11.

The original „Friedlander“-evidence from Berkeley is shown on the top left. It was obtained from the study of interactions of 100 GeV Fe-ions in nuclear emulsions: the mean free path of relativistic secondary fragments is given. We refrain from explaining details in this talk. However, it should be noted that this central evidence was never retracted to the Lawrence Berkeley Laboratory. The original „Alexander“-evidence from Dublin in 1958 is shown on the top right - again, neither retracted, nor disproved. (They also saw an „enhanced cross-section“ for these pions). The most significant experiments for a “reduced mean-free-path of freshly generated relativistic secondary particles“, as anomalons could be described more accurately, have been obtained at the LHE, JINR in Dubna using relativistic heavy ion beam interactions in bubble chambers (two bottom figures). Here, the statistical significance is - in the speaker's opinion - beyond doubt, and this „beyond doubt“ is strengthened by the fact that no other laboratory challenged these results, nor did - to our knowledge - any laboratory in the West care to reproduce these experiments. So much for this history.

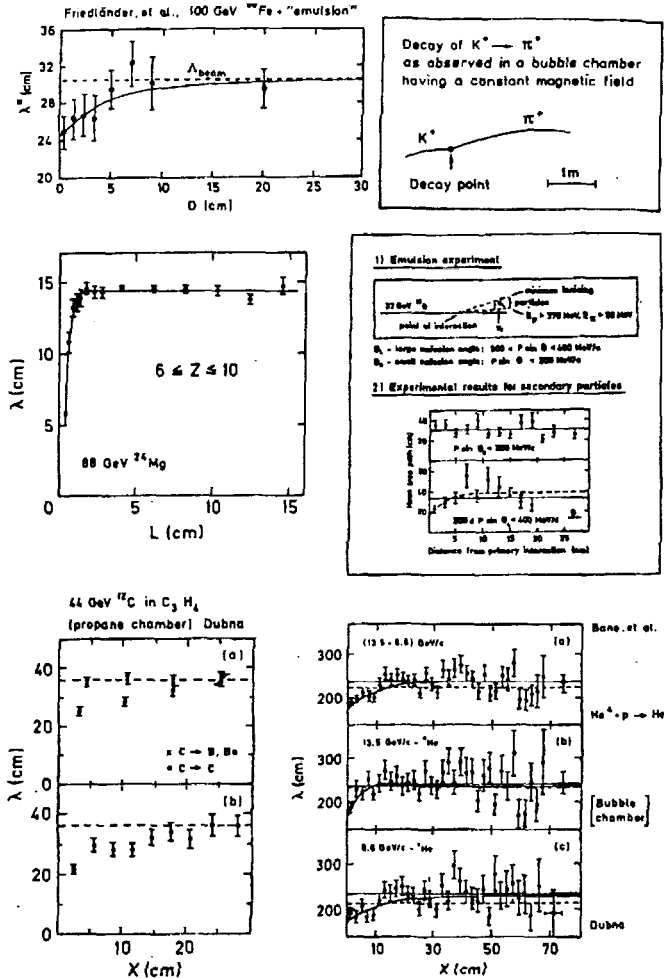

Fig. 11 Some pro-anomalous evidences, as taken from [13]

Another set of evidences, possibly connected to the anomalous phenomena, has been obtained using the so-called Cu-block techniques. The experimental set-up is shown on top of Fig. 13. Two Cu-disks, 8 cm \varnothing and 1 cm thick, are irradiated either in contact or at a 10 or 20 cm distance. After irradiations with 36 and 72 GeV ^{40}Ar from the Bevalac (LBL), the amount of ^{24}Na in the Cu-disks was determined with standard gamma-spectroscopy, and the results are shown in Fig. 13 (bottom). It is impossible to describe the details of this experiment and its interpretation here (see [14]). However, the resulting analysis shows that the behavior of ^{24}Na (and ^{28}Mg) in Cu, produced by 36 GeV ^{40}Ar is completely understandable using accepted physics concepts. The behavior at 72 GeV ^{40}Ar is again not understood by the same concepts:

- The increase of R_i ($d=0\text{cm}$) with increasing Ar-energy can only be understood by the hypothesis that secondary fragments have about 2 times larger cross sections at the higher Ar energy than at the lower Ar-energy.

- The decrease of R_i with increasing distance can be explained (for details see [15]) by the hypothesis that these strange secondary fragments, produced at the larger Ar energy, are emitted at large laboratory angles. Nevertheless, these fragments produce substantial amounts of ^{24}Na in Cu when they can interact with Cu at wide angles. This is shown in Fig. 12b: at wide laboratory angles, one observes a rather broad distribution in $R_0(^{24}\text{Na})$ experimentally explaining directly

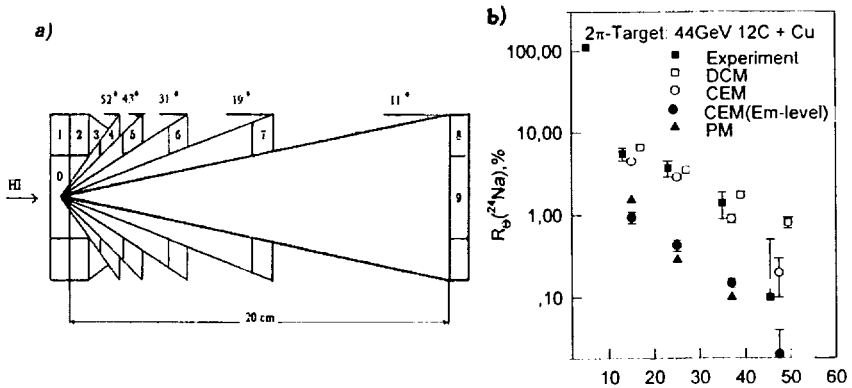

Fig. 12. The $2\pi\text{Cu}$ -target experiments to study a wide-angle emission of „ ^{24}Na -producing secondary fragments“: (a) experimental set-up, (b) results for the reaction $44 \text{ GeV } ^{12}\text{C} + \text{Cu}$, as studied in Dubna

the decrease of $R(d)$ with distance d , as observed in Fig. 13 for $72 \text{ GeV } ^{40}\text{Ar}$. The theoretical distribution in Fig. 12b for the same particles is much more forward focussed (see [15] for details).

These properties of energetic relativistic ions were observed for a variety of relativistic ions at several laboratories, as shown in Fig. 13. The „effect“ appears to be only a function of the total ion energy $E(\text{total})$, and it is only observed for $E(\text{total}) \geq$ approximately 35 GeV.

All the described experiments have recently been interpreted by Kulakov et al [4] at the LHE, JINR in a modern way, considering the results from the analysis of the momentum of secondary fragments produced within relativistic interactions and observed with LHE bubble chambers. The results are shown in Fig. 14 and Table 4. The emission of energetic secondary particles with $E > 0.8 \text{ GeV}$ (ergo: being capable to produce ^{24}Na in Cu) generated in the interaction of relativistic ^{12}C -ions in a propane chamber is narrow for $41.5 \text{ GeV } ^{12}\text{C}$ and broad for $15.1 \text{ GeV } ^{12}\text{C}$. The behavior of the same secondary fragments with respect to ^{24}Na produced at wide angles is just the other way round. One possible hypothesis is that relativistic secondary fragments emitted at large angles have indeed a proper low momentum, as requested by theory. However, the same particles produce more ^{24}Na in Cu, as allowed by the same theory. In other words, we have again anomalous observed with $44 \text{ GeV } ^{12}\text{C}$. Obviously, we are all looking ahead to study these effects even better at larger ^{12}C -energies available, let us hope, soon at the Nuclotron of the Laboratory for High Energies, JINR.

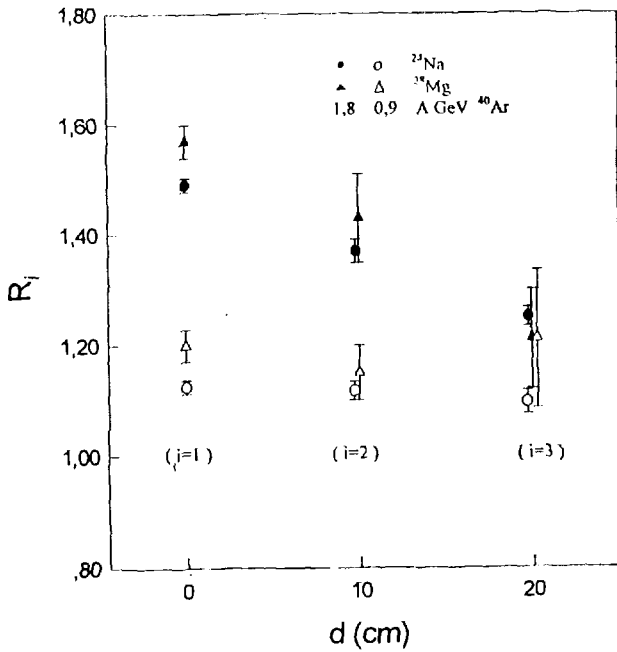
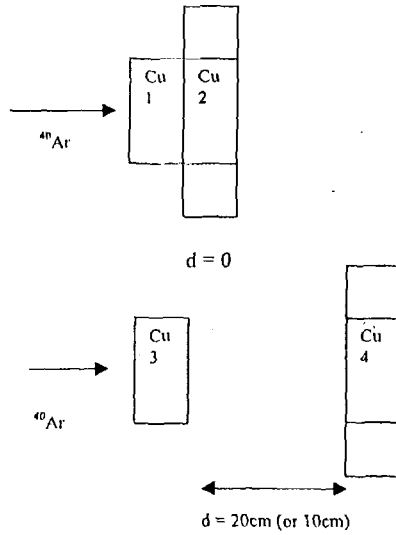
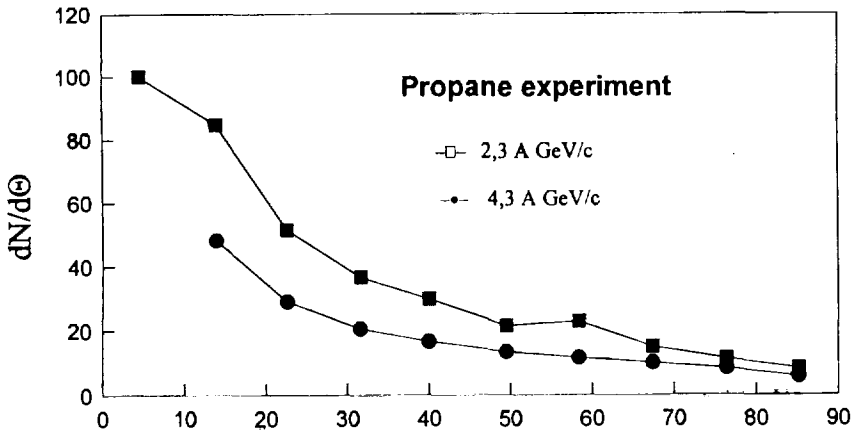

Fig. 13 . C-block experiments: (top) experimental set-up, (bottom) results

Table 4. Observables outside $> 19^\circ$ (% of all observables)

Propane bubble chamber		Cu - configuration experiments	
Energy (^{12}C)	Second. Protons ($E > 0.8 \text{ GeV}$)	Energy (^{12}C)	Yield (^{24}Na)
15.1 GeV	~ 40	25 GeV	1.7 ± 2.1 (Ref. 3)
41.5 GeV	~ 22	44 GeV	5.6 ± 0.4 (Ref. 4)



⊖

Fig. 14 (and Table 4): The angular distribution of fast ($> 1 \text{ GeV}$) secondary protons produced by 15.1 GeV and 41.5 GeV ^{12}C , respectively. The 'drawing' gives the results for momentum measurements, the 'Table 1' right side - the results for effectiveness to produce ^{24}Na in Cu.

5. Acknowledgements

The speaker wants to thank the Directorate and coworkers of the JINR in Dubna for their kind hospitality one could enjoy as visiting scientist from 1966 until today, always being granted GEDANKENFREIHEIT in Science!

The speaker thanks the JINR Director Prof. V.G.Kadyshevsky for his kind invitation to present this talk at the 85-th Session of the JINR Scientific Council (January 13-15, 1999, Dubna). I am grateful to my colleagues Drs. M.I.Krivopustov and A.N.Sosnin for their help in preparation of the publication.

References:

1. Krivopustov, et al.: First experiments on transmutation studies on ^{129}I and ^{237}Np using relativistic protons of 3.7 GeV. JINR E1-97-59 (1997), J.Radioanal. and Nucl. Chem. Lett. 222(1997) 267 - 270
2. Wan, et al.: Transmutation of radioactive waste with the help of relativistic heavy ions. JINR E1-97- 349 (1997), Kerntechnik 63 (1998) 167 - 177
3. Ochs, et al.: Transmutation of ^{129}I and ^{237}Np using spallation neutrons produced by 1.5, 3.7 and 7.4 GeV protons. JINR E1-99-1 (1998), Nucl. Instr. & Methods A, accepted for publication
4. Kulakov, et al.: On different experimental behaviour of fast secondary particles produced in ^{12}C interactions at relativistic energies as studied with radiochemistry and in a propane chamber. JINR E1-98-51(1998), Kerntechnik 63 (1998) 249 - 254
5. Brandt, et al.: Invited talk presented at the 19th International Conference on Nuclear Tracks in Solids, Besancon, France, 31.8. - 5.9. 1998, to be published in „Radiation Measurements“ (1999)
6. C.Rubbia et al., CERN/AT/ 95-53 (ET), 1995, Preprint, CERN, Geneva, Switzerland
7. R.G.Vassilkov et al., Atomn. Energiya 70 (1995.) 257 - in Russian
8. S.Andriamonje et al., Phys. Lett. B 346 (1995) 697 - 709
9. I.Calero et al., Nucl. Instrum. Methods A 376 (1996) 89 -103
10. V.N.Sosnin et al., Kerntechnik 63 (1996) 178 - 182
11. P.Zucker et al., Proc. 2nd Conf. Accelerator Driven Transmutation, Kalmar, Sweden, June 3 -7, 1997, Vol.I, 527 - 533
12. Details can be found in R.Brandt et al., Science International (Lahore) 4 (1992) 3 - 6,
13. B.A. Arbuzov et al., Nucl. Tracks Radiat. Meas. 19 (1991) 557 - 567
14. G. Dersch et al., Phys. Rev. Lett. 55 (1985) 1176 - 1179
15. R.Brandt et al., JINR E1-95-502 (1995), Preprint, to be resubmitted to Phys. Rev. C
16. V.A.Voronko et al., Atomn. Energ. (Russian), 68(1990), 452

Received by Publishing Department
on October 12, 1999.

**SUBJECT CATEGORIES
OF THE JINR PUBLICATIONS**

Index	Subject
1.	High energy experimental physics
2.	High energy theoretical physics
3.	Low energy experimental physics
4.	Low energy theoretical physics
5.	Mathematics
6.	Nuclear spectroscopy and radiochemistry
7.	Heavy ion physics
8.	Cryogenics
9.	Accelerators
10.	Automatization of data processing
11.	Computing mathematics and technique
12.	Chemistry
13.	Experimental techniques and methods
14.	Solid state physics. Liquids
15.	Experimental physics of nuclear reactions at low energies
16.	Health physics. Shieldings
17.	Theory of condensed matter
18.	Applied researches
19.	Biophysics

Брандт Р.

E1-99-251

Измерение выхода нейтронов и трансмутации радиоактивных изотопов в соударениях релятивистских ионов с тяжелыми ядрами

Данная работа подготовлена по материалам доклада, представленного на 85-й сессии Ученого Совета ОИЯИ. В работе обсуждаются аспекты экспериментального исследования проблемы переработки радиоактивных отходов посредством трансмутации в полях нейтронов, генерируемых пучками релятивистских частиц. Приводятся результаты работ по измерению выхода нейтронов в тяжелых мишенях под действием пучков протонов с энергией до 3,7 ГэВ, а также сечений трансмутации некоторых продуктов деления (I-129) и актинидов (Np-237) с использованием радиохимических методов, активационных детекторов, твердотельных ядерных трековых детекторов и других методик. Эксперименты проводились на ускорительном комплексе Лаборатории высоких энергий ОИЯИ. Проводится обсуждение результатов, полученных другими экспериментальными группами.

Сообщение Объединенного института ядерных исследований. Дубна, 1999

Brandt R.

E1-99-251

Measurements of Neutron Yields and Radioactive Isotope Transmutation in Collisions of Relativistic Ions with Heavy Nuclei

The paper is based on the report presented at the 85th Session of the JINR Scientific Council. Some aspects of experimental studies of the problem of reprocessing radioactive wastes by means of transmutation in the fields of neutrons generated by relativistic particle beams are discussed. Research results on measurement of neutron yields in heavy targets irradiated with protons at energies up to 3.7 GeV as well as transmutation cross sections of some fission products (I-129) and actinides (Np-237) using radiochemical methods, activation detectors, solid state nuclear track detectors and other methods are presented. Experiments have been performed at the accelerator complex of the Laboratory of High Energies, JINR. Analogous results obtained by other research groups are also discussed.

Communication of the Joint Institute for Nuclear Research. Dubna, 1999

Макет Т.Е.Попеко

Подписано в печать 3.11.99
Формат 60 × 90/16. Офсетная печать. Уч.-изд. листов 2,17
Тираж 390. Заказ 51679. Цена 2 р. 60 к.

Издательский отдел Объединенного института ядерных исследований
Дубна Московской области