



“KOZLODUY NPP” - Pls., BULGARIA



ISO 9001



DICS Intertrade Ltd.
Tzarigradsko Shosee 7-th km
1784 Sofia, Bulgaria

UNITS 3 AND 4 STEAM GENERATORS NEW WATER LEVEL CONTROL SYSTEM

Dim. Dragoev, DICS Intertrade Ltd. Managing Director

St. Genov, Senior Expert, Engineering Support Division, PP-1, KNPP

ABSTRACT

Despite of efforts of the different NPP's having reactors WWER-440/B-230 to implement safety improvement measures during first 10-15 years of operation of this type of reactor their major safety problems according to the recent safety standards were not eliminated and were subject of international concern.

The systematic evaluation of the deficiencies of the original design of this type of reactors had been initiated by IAEA in the beginning of 1990 and brought to developing a comprehensive list of safety problems, which required urgent implementation of safety measures in all plants- TECDOC-640.

After 1991, when following the Bulgarian Ministry council decision, Units 1 and 2 have been shut down for two and one year respectively for implementation of urgent measures for safety upgrading, Kozloduy NPP developed and implemented the so called “Short term program for safety upgrading”. The program itself consists of two parts – part 1 – “Technical aspects” and part 2 - “Operational aspects”. During the process of implementation an in-depth safety analysis was performed aiming to define current level of the safety, based on internationally accepted analysis methodology. As a result of the analysis a set of specific measures was defined and unified in so called “Complex program for modernization of Units 1 – 4” – PRG'97.

Modification of some important for the safety systems was performed in the frame of the third stage of the “Short term program...”, including here the installation of the new Steam Generators Water Level Control System(SGWLCS) for unit 3 and 4 – Theme M.8.5.

Design and realization of the project for Unit 4 is financed by EC PHARE program.

Design and realization of the project for Unit 3 is financed by KNPP funds.

The new system main designers are TRICONEX(UK) and DICS Intertrade Ltd, Bulgaria.

The main suppliers are companies TRICONEX(UK), HOPKINSONS(UK), BERNARD(FRANCE) and DICS Intertrade Ltd, Bulgaria.

The Steam Generator Water Level Control System is one of the most important for the normal operation systems, related to the safety and reliability of the units.

The main upgrading objective for the SG level and SGWLC System modernization is to assure an automatic maintaining of the SG level within acceptable limits (below protections and interlocks) from 0% to 100% of the power in normal operation conditions and in case of transients followed by disturbances in the SG controlled parameters - level, steam flow,

feedwater flow and/or pressure/temperature.

To achieve this objective, the computerized controllers of new SG water level control system follows current computer control technology and is implemented together with replacement of the feedwater control valves and the needed I&C equipment.

1. OVERCOMING PREVIOUS PROBLEMS

The new SGWLC System shall allow overcoming of the problems of the existing system identified during the time of plant operation such as:

- Very low accuracy of flow measurements at low flow rates (a proper indication of flow is only approximately 25% of the used range).
- Absence of the pressure and the temperature compensation in the steam flow and feedwater flow measurements.
- Long response time of controller/actuator/ for full opening/closing -35s to 40s, which causes problems in maintaining the SG level during some transients.
- The coupling between motor and reductor and components in the reductor are of low reliability.
- The position sensors regularly suffer as a result of overtemperature and unreliable construction.
- Unreliable detection of a transmitter failure.
- Unreliable transmission of signals from the PI controller to the valve actuator.
- Problems in SG level control in many transients associated with significant or rapid changes in steam or water flow, temperature etc.

Some results of current SGWLCS controllers VP-12 (Russian original design) of Units 1 to 4 performances from the beginning of Units commissioning are presented on Figure No 1 “VP-12 failures and corresponded Reactor Scrams and Loss of Produced energy”.

2. PROPOSED FEATURES

The New System shall utilize the modern technology and shall allow overcoming of the identified problems by using:

- Reliable transmitters, redundant for the essential functions with live zero and automatic validation facilities;
- Proven microprocessor technology for control functions;
- Fast response control valves with adequate capacity;
- The required control facilities shall allow the automatic control of SG level from 0% to 100% load, covering also the design transients;
- The equipment shall be “maintenance free” between refueling outages.

The system shall also include the fulfillment of the following functions:

- Fault detection and appropriate automatic actions;
- Temperature and pressure compensation for feedwater and steam measurements;
- Shrink and swell compensation due to pressure variations;
- Smooth transfer functions when switching operating modes (from manual to automatic or backward);
- Suppression of hunting between steam generators.

Constraints:

The modernization shall take into account the following restrictions:

- Setting of the protections, interlocks and level setpoint shall not, in any case, be modified;
- Actuators shall not be air-driven or to use other pneumatic technology;
- Actuators shall not be controlled by using of frequency modulation;
- Following transients the level shall come back to its referent value as fast as possible, with a maximum threshold overstep as small as possible. The allowed level deviation shall be less than ± 50 mm of the SG nominal level;
- The equalizer stability margin shall be as broad as possible.

3. SYSTEM CLASSIFICATION

The KOZLODUY NPP Steam Generator Water Level Control System (S.G.W.L.C.S.) is a system for normal operation important to safety. Therefore, the system shall be classified as suitable for industrial grade, heavy duty and high performance based on well-established software, hardware and industrial practices.

4. STARTING OF THE PROJECTS FOR UNIT 4 AND 3

The Tender Technical Specification and all necessary attached documents were developed and approved in 1999 in accordance of the European Committee DIS (Development and Implementation of Supply Contracts) manual.

In May 2000 the Tender Competition was held on.

In October 2000 the Contract for supplying the SGWLCS for Unit 4 financed by PHARE project BG 9809-01-01 was signed with main supplier TRICONEX EUROPE, followed by KNPP own contract for Unit 3 with TRICONEX EUROPE.

5. SYSTEM FUNCTION, STRUCTURE AND PARAMETERS

5.1. SYSTEM FUNCTION

The function of the Steam Generator Water Level Control Systems is to regulate the level of the water of the six steam generators in the limit of ± 50 mm, in all design conditions and transients.

5.2. SYSTEM STRUCTURE AND PARAMETERS

The system is based on triple modular redundant controller TRICON, ver. 9, class 1E certified.

The controller ensures 100% availability, which eliminates stoppages, caused by system failure. The powerful processing and data storage capability of the controller enables flexible and adaptive control algorithm to be performed. These unique features will allow new diagnostic and control functions to be integrated in the future.

The structure of the system provides sensor dual and triple redundancy, which is also distinguishing feature, compared to the old control systems. The measurements of the Water level are tripling redundant. Water and Steam flows and the pressure on the first stage of the turbo generators are dual redundant. Special algorithm allows removal of a failed transmitter and replacement with a new one online. All transmitters are provided with dual power supply. The actuators are class 1. The 380V AC Supply to the actuators is in accordance with the Power supply system in the nuclear unit.

The systems are mounted in three enclosures in order to avoid common mode failure. Every cabinet has dual redundant power supply.

Each of the manual control panels consists: Control unit BY 21M, CV Position indicator and Water level Set point potentiometer.

One Light Indicator "Call from cabinet" per SG is available on the Main Control Room console. Every cabinet is furnished with indicators showing detailed information for the status of the system.

Two Workstations are provided for a system for ensuring HMI high availability.

The structure of the system, together with the interface to the object and HMI are shown on diagrams SGWLCS structure – Figures No 2, 3, and 4.

5.3. CONTROL ALGORITHMS

The modern structure of the basic software of platform is another distinguishing feature of the system. It is based on the IEC 1131 Standard Function block programming. The basic software and the configuring module are proven through thousands of applications, most of them critical process control and protection applications. It is certified by TUV and recently by NRC for class 1E applications.

This truly universal control platform provides excellent means for developing and applying adaptive algorithms for this application.

The offered dual and triple redundancy of the instrumentation, together with the reliable

algorithms for assessing and isolating the bad input signals will prevent the system from erroneous control and it will indicate the failed transmitter on time, restructure the control algorithm accordingly and will permit replacement of the failed transmitter online.

The adaptive features of the control algorithm will solve the problems of not responding properly to the transients, when rapid changes of FW temperature, Steam flow, turbine trip, reactor trip occur.

The algorithm provides the compensating of the Steam, Water Flow and the Water level by integrating correcting algorithms.

A correction of the measurement of the Pressurizer Water level is also provided, although this level is out of the scope of the contract.

An adaptive PI controller parameters adaptive tuning is also included.

The Control under 15 % of the Thermal power is provided by two additional legs of the control algorithm:

- The first one, which makes assessment of the Steam flow through calculation of the neutron Power;
- The second one, which calculates the Feed water flow, utilizing the dP across the CV and the signal of opening of the CV.

A special self-correcting algorithm is provided for the drifting of the Steam flow assessed value in time.

5.4. INTERFACE TO THE OBJECT UNDER CONTROL, INCLUDING HMI

The SGWLCS interface to the object can be split up in three parts:

- Object status sensors signals: temperature, pressure, water level, steam and water flow, control valve opening;
- Actuators of the control valves and interface to manual and remote control consoles;
- Operator Work Stations communication network - HMI.

The first two parts are consolidated in one complete documentation, which was prepared after judicious investigation of the object from the point of view of instrumentation suitability, anchoring points, field operators working and environment requirements.

The results were discussed with, and approved by the KNPP management.

The developed documentation is issued to KNPP for initiating a tender for selection a company for implementing the cabling.

The Network for integrating the Control cabinets, the Workstations and for the purpose of debugging and tuning – portable Note book PC is provided for IEEE 802.3 network, TCP/IP protocol, 10 Mbaud speed.

The Operator HM Interface Work Station is being developed according to the KNPP requirements and according to the Company's good practice.

Copies of the views of the displays are enclosed.

Specific hierarchy of the access to specific parts of the data base or control functions of the stations is provided.

5.5.SIMULATING FACILITIES

The simulating facilities are developed in two directions:

- Static Testing;
- Dynamic testing.

This part of development of DICS Intertrade products is considered to be very substantial for achieving success on time, without causing disturbances to the start up procedure. This development is conducted according to DICS Intertrade QA System, based on ISO 9001.

For this purpose a team of specialists responsible for these facilities is appointed. The testing facilities are developed concurrently with the development of the systems.

Logic and metrological evaluations of the system are implemented by the static testing.

Dynamic testing evaluates the integrity of the system, as well as, facilitates the tuning of the system parameters in order to achieve proper reaction on a simulation of preliminary defined disturbances.

Development of a Simulator of six steam generators and the associated equipment, including the nuclear reactor, the primary coolant loops, and the corresponding controllers is developed. The input data for starting this development was acquired by DICS Intertrade Ltd. through the developed and installed by the Company Information system.

The Specification and block diagram of the Simulator is enclosed.

5.6. ERECTION AND INSTALLATION

Seismic reinforcement of new SGWLCS controllers and their supports is foreseen, in accordance with Anchoring point seismic spectra.

The earthquake-resistant anchoring shall be implement following the Erection Specification for Cabinet installation.

Equipment Disposing Diagram is included.

The installation of new SGWLCS for Unit 4 is foreseen during Unit 4 Annual Outage 2001.

The installation of new SGWLCS for Unit 3 is foreseen during Unit 3 Annual Outage 2002.

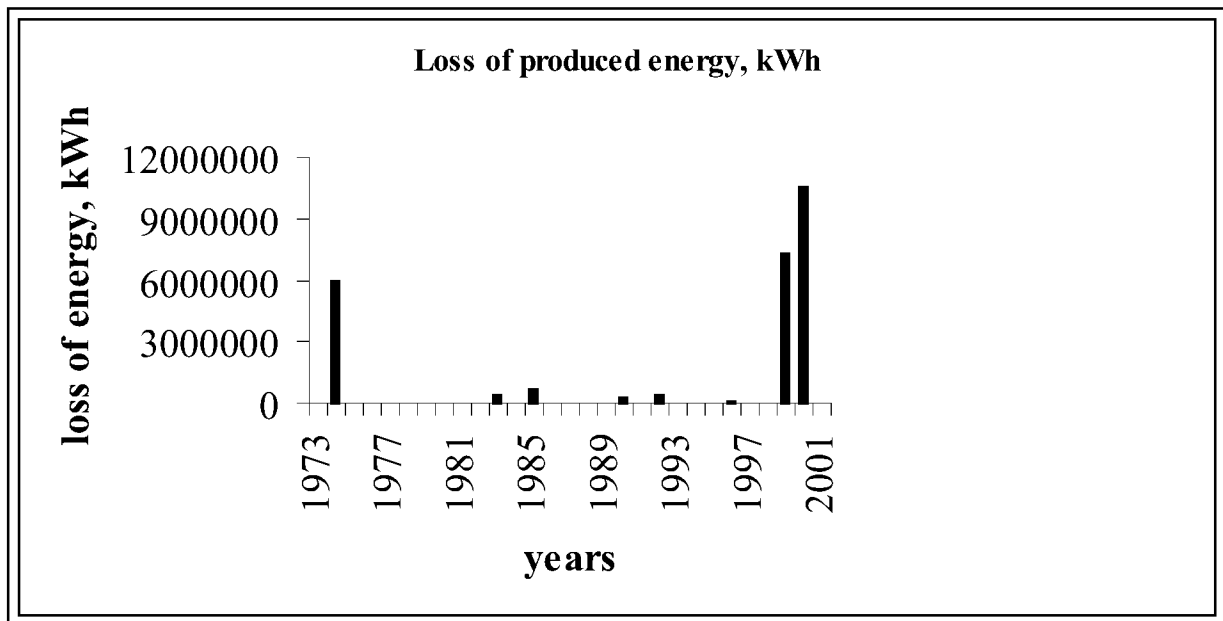
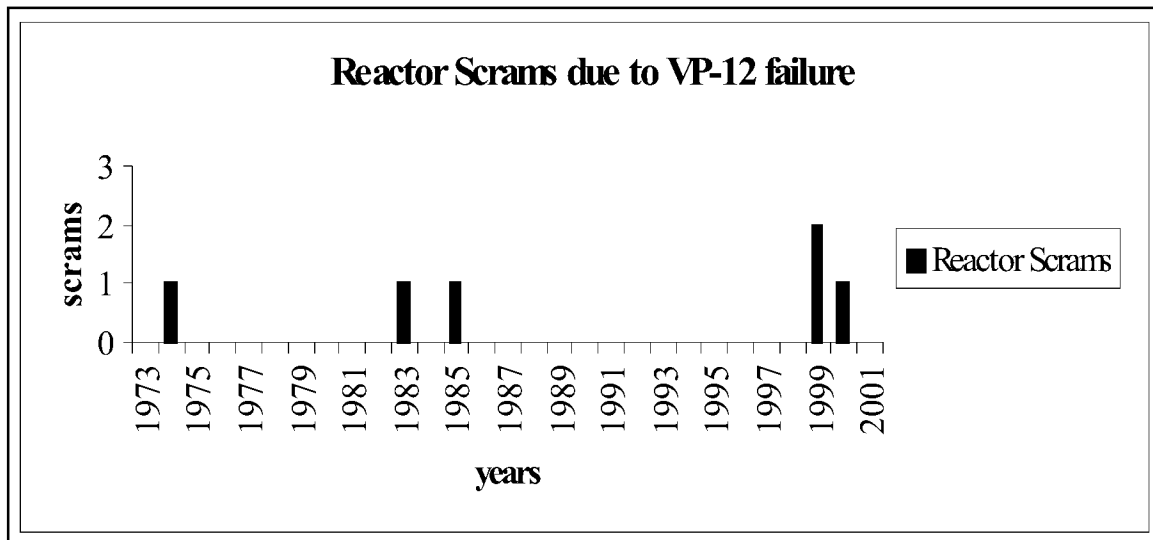
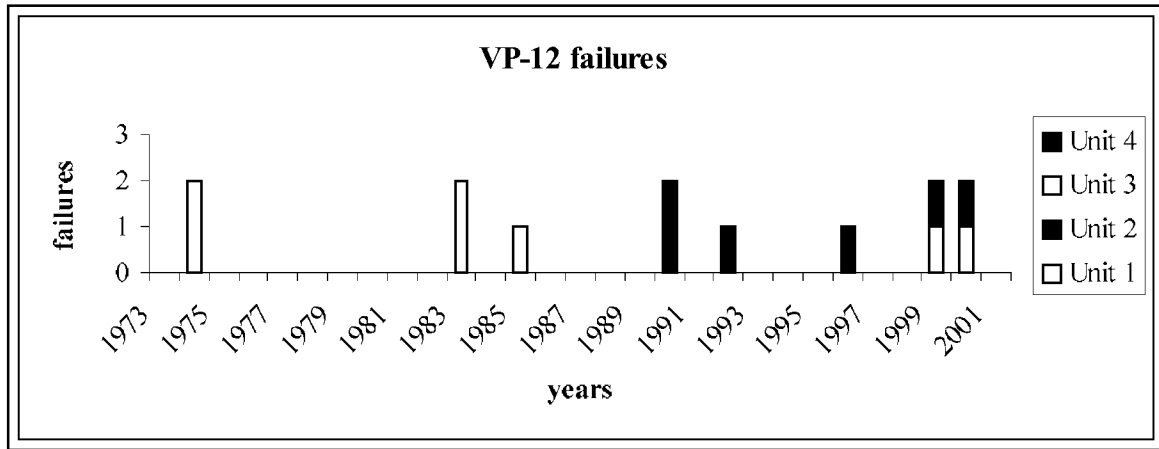

Figure No 1 - VP-12 failures and corresponded Reactor Scrams and Loss of Produced Energy

Figure No 2 – SGWLC SYSTEM STRUCTURE

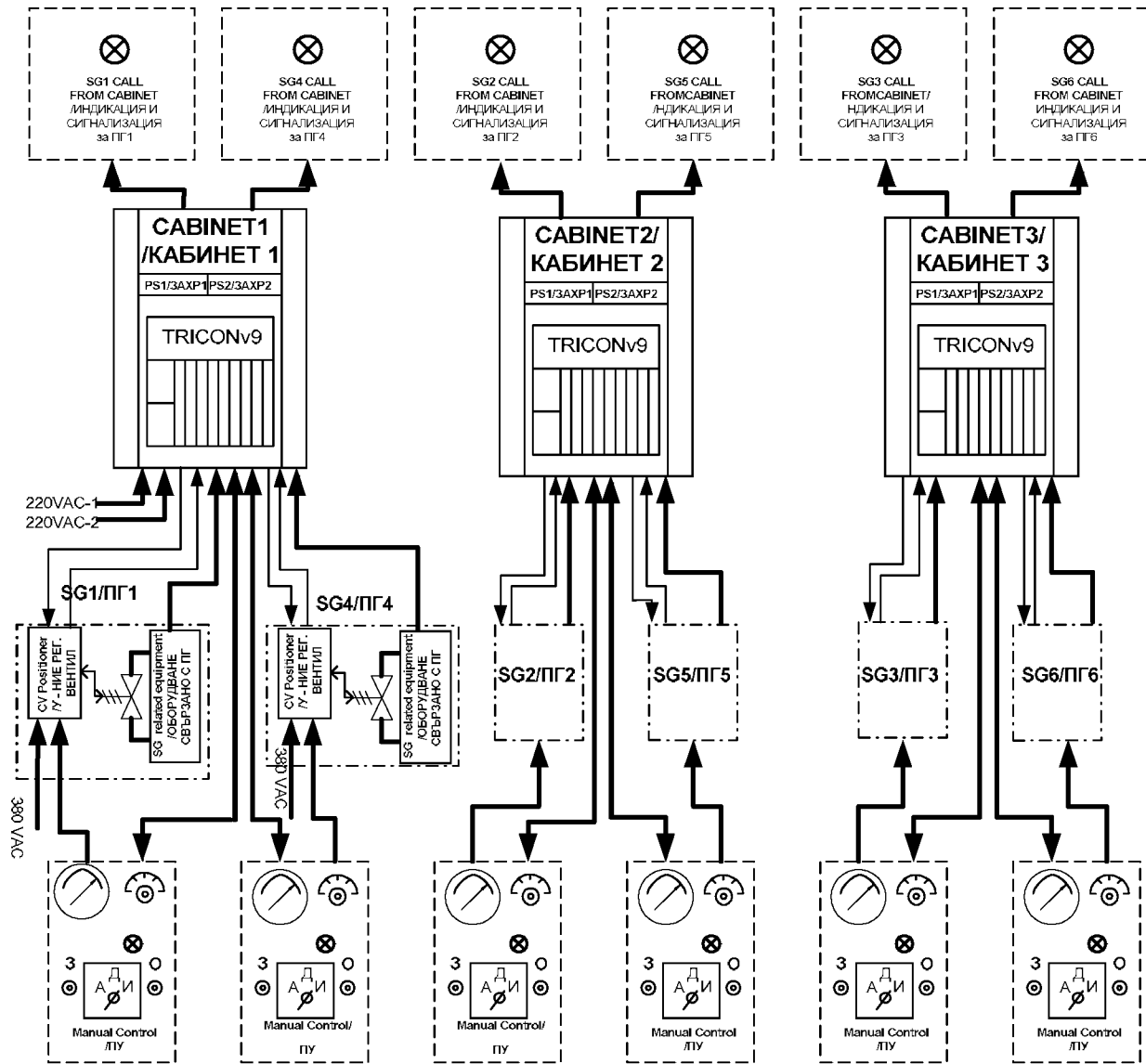

Figure No 3 - SGWLC SYSTEM INSTRUMENTATION STRUCTURE

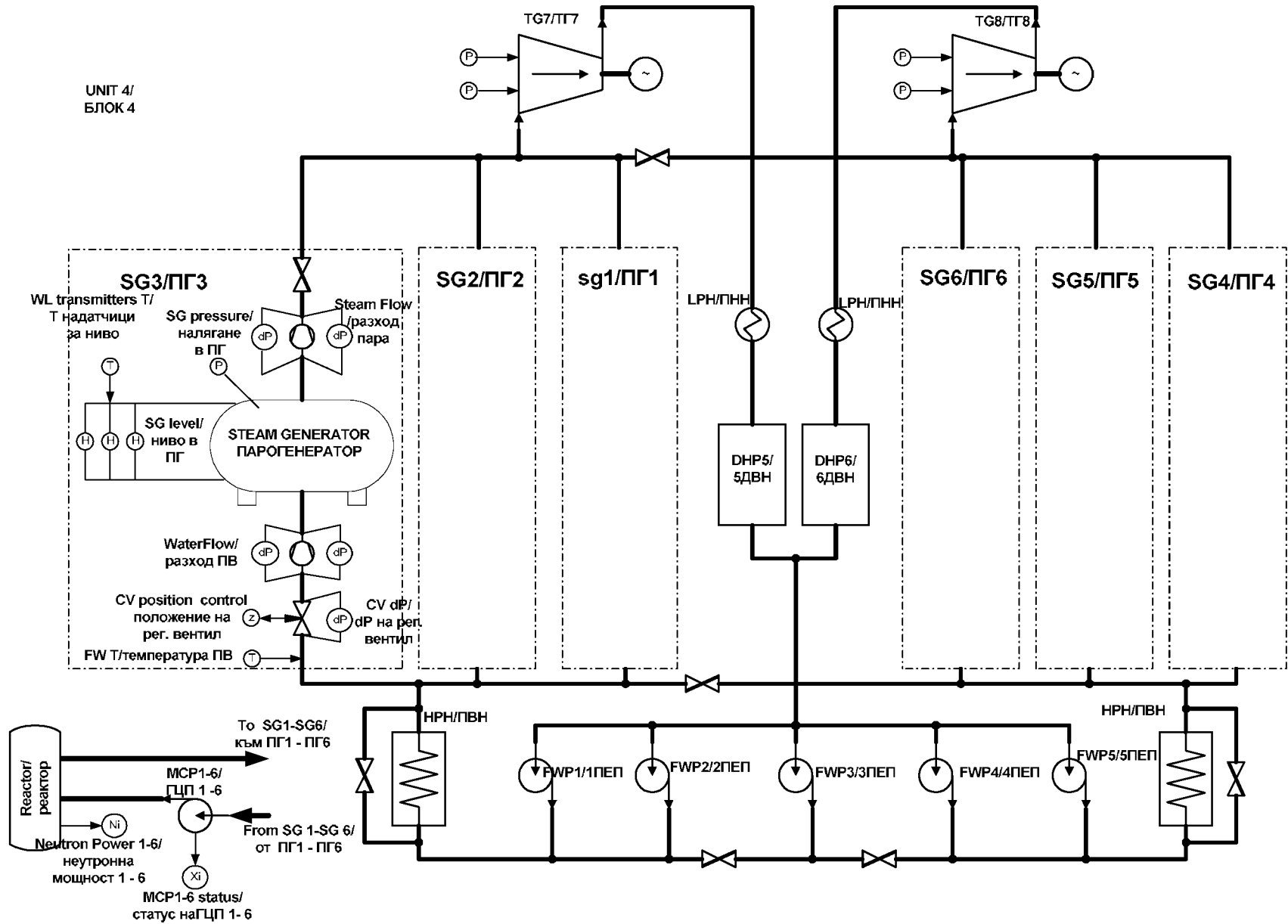

Figure No 4 – INTEGRATING LAN

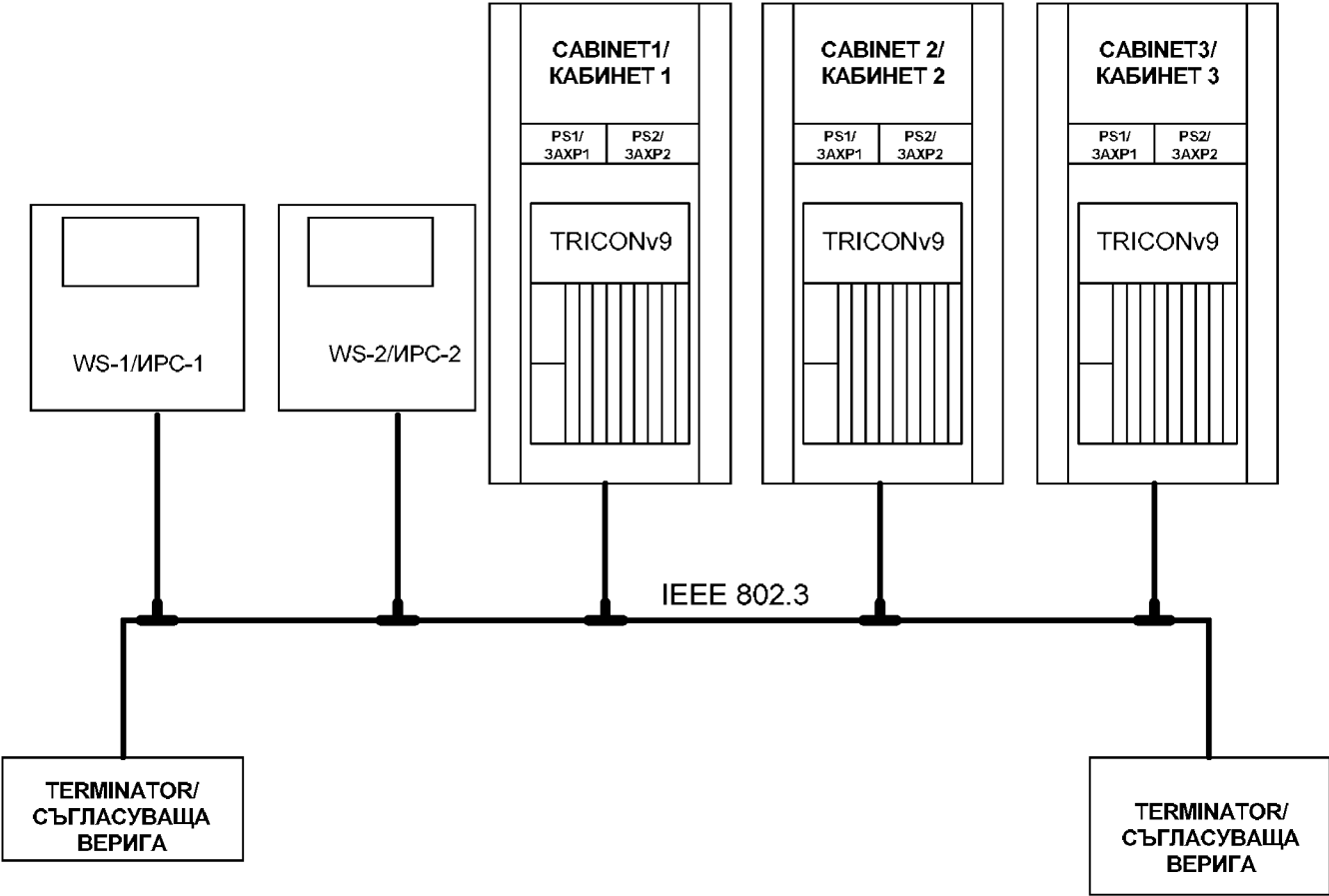
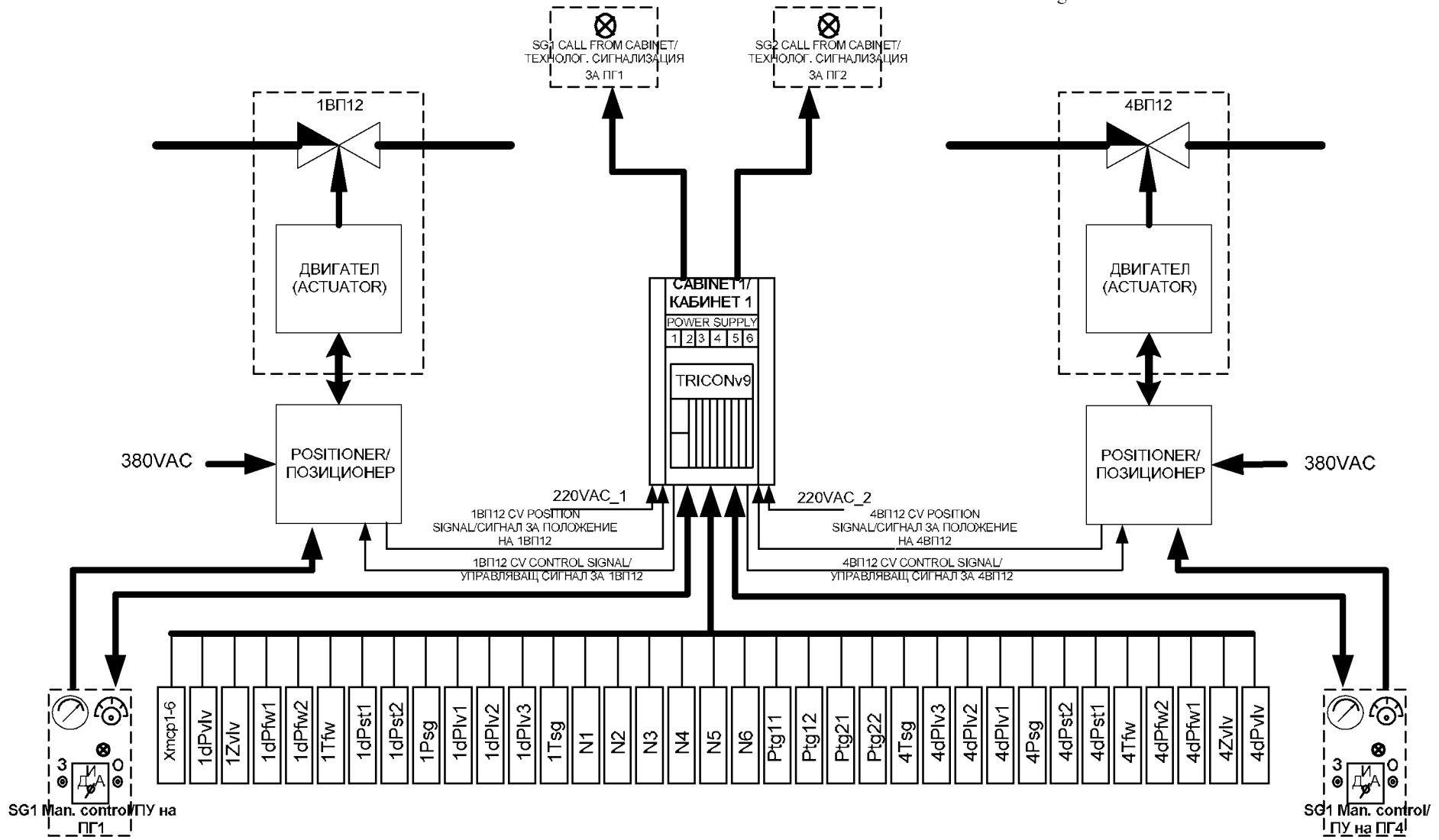
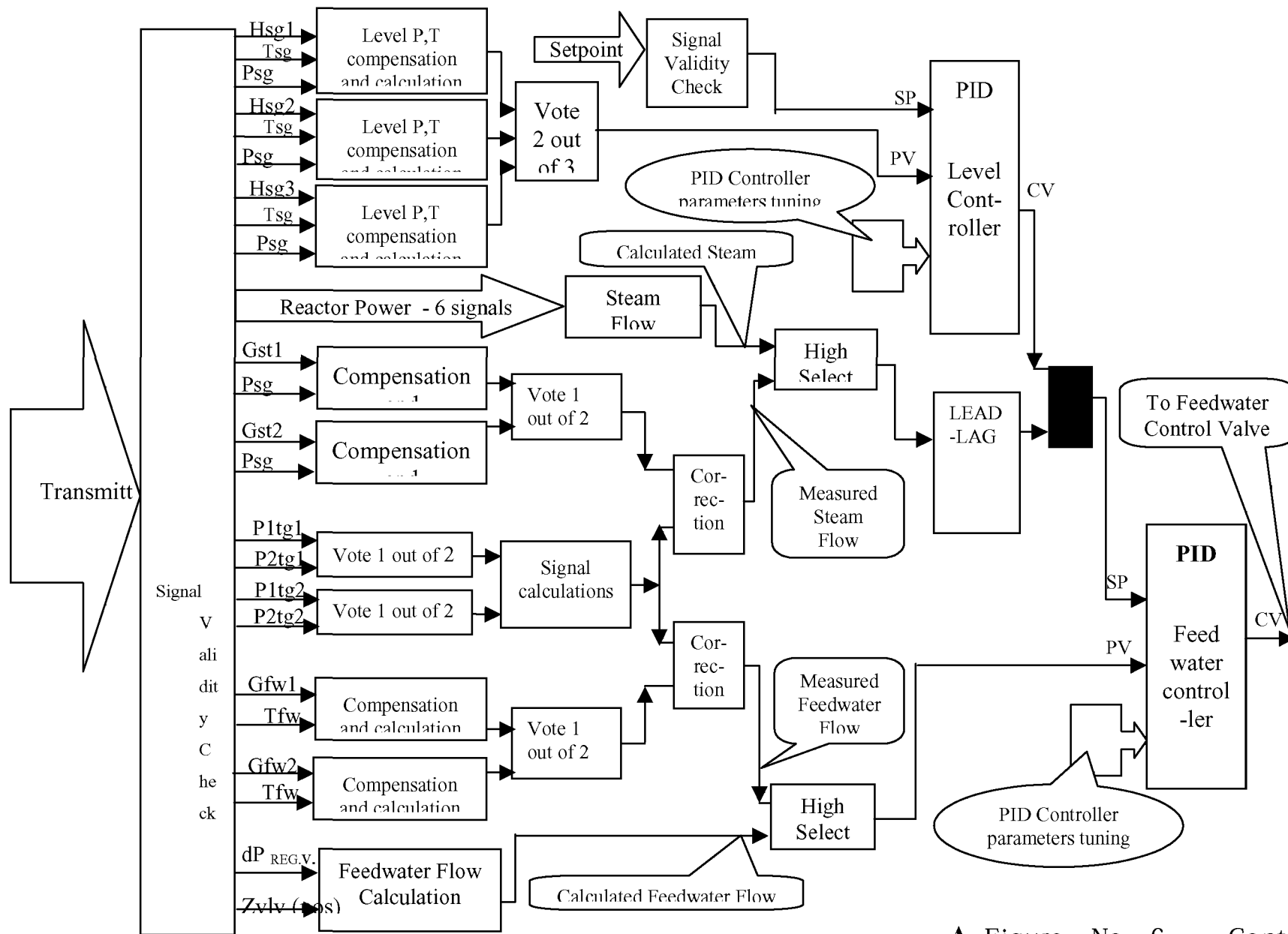

Figure No 5 – ONE CABINET OBJECT I/O INTERFACE





A. Figure No 6 - Control

ПАРОГЕНЕРАТОР 2

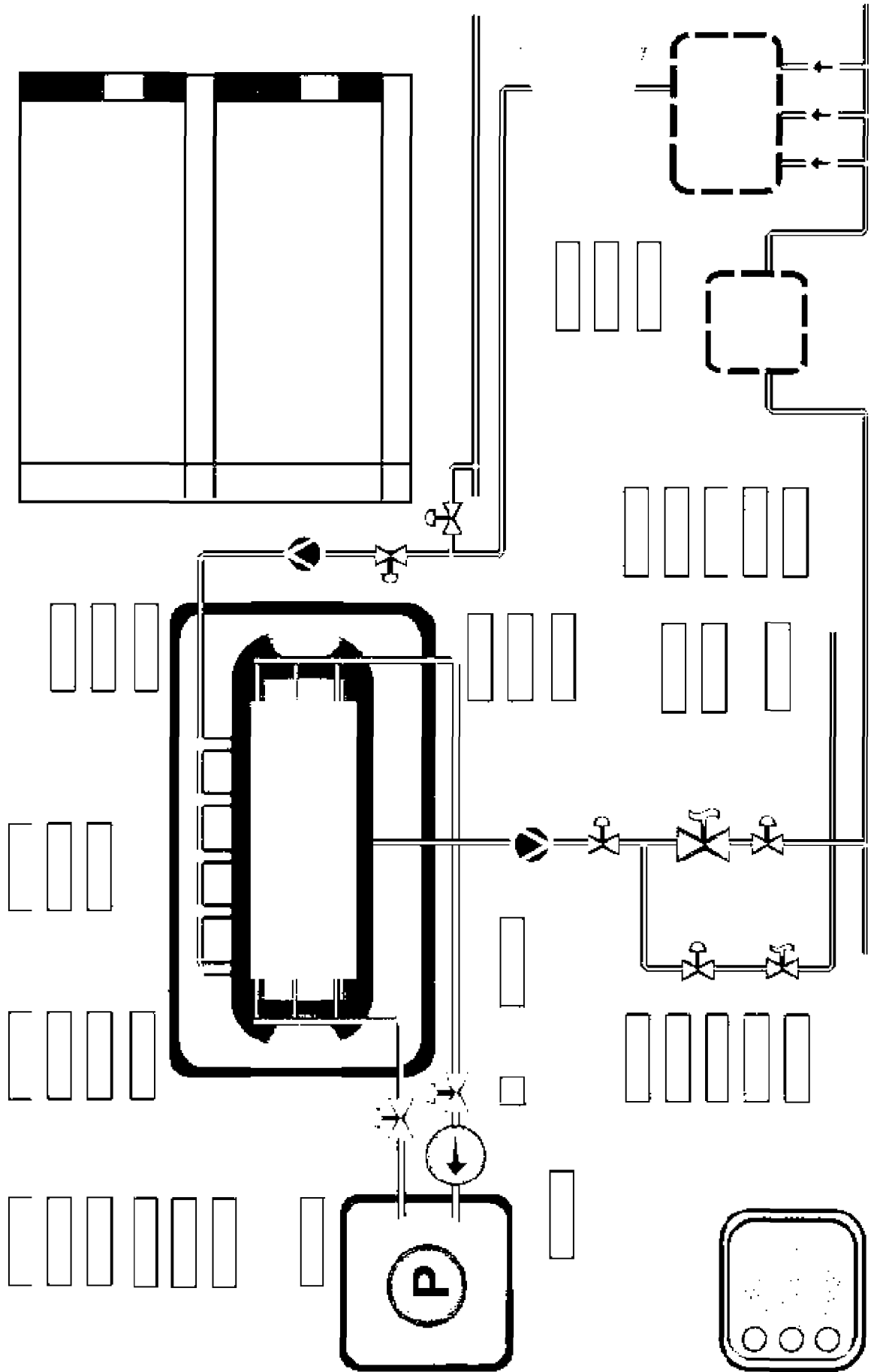

ПАРОГЕНЕРАТОРИ 1,2,3,4,5,6

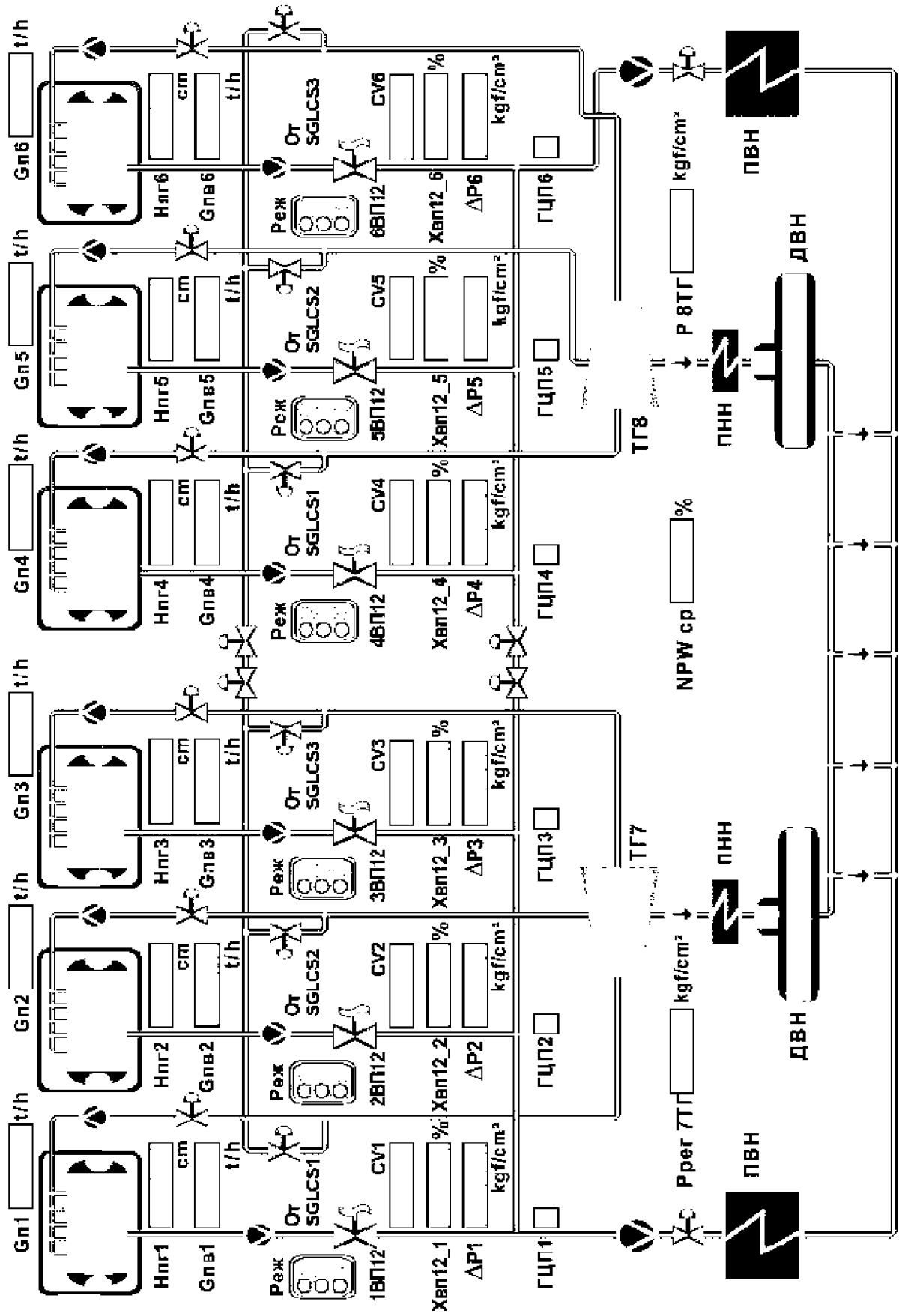

Simulator model structure diagram

