



ICANS-XV  
15<sup>th</sup> Meeting of the International Collaboration on  
Advanced Neutron Sources  
November 6-9, 2000  
Tsukuba, Japan

**8.2**  
**JKJ ACCELERATOR TIMING SYSTEM**

C. Ohmori<sup>1\*</sup>, Y. Mori<sup>1</sup>, M. Yamamoto<sup>2</sup> and M. Yoshii<sup>1</sup>

<sup>1</sup>High Energy Accelerator Research Organization,  
Tsukuba 305-0801, Japan

<sup>2</sup>Japan Atomic Energy Research Institute,  
Tokai 319-1195, Japan

\*E-mail:chihiro.ohmori@kek.jp

**Abstract**

The JKJ (JAERI-KEK Joint Project) accelerator complex[1] consists of the linear accelerator, 3 GeV and 50 GeV synchrotrons. To minimize the beam loss during the beam transfer from the 3 GeV synchrotron to the 50 GeV one, the synchronization of the two RF system of the rings is very important. To reduce the background from the high and low momentum neutron, the neutron beam chopper will be employed. The 3 GeV RF will be also synchronized to the chopper timing when the beam goes to the neutron facility. The whole timing control system of these accelerators and chopper will be described.

**1. Introduction**

The 3 GeV synchrotron will provide 330  $\mu$ A for the meson and neutron physics experiments. It will be also used as a booster-synchrotron for the 50 GeV synchrotron. From the 50 GeV synchrotron, the beam will provide high energy, nuclear physics and neutrino experiments. Because the beam loss in these accelerators should be low to maintain, the beam transfer between accelerators is very important. And, to obtain a high quality data with low background, the collaboration between user facility and accelerator is also significant. The neutron facility will use a neutron beam chopper to reduce the major background from the fast and high energy neutron. However, the chopper is heavy iron and rotates with fast speed of 40,000 rpm. To use the neutron chopper efficiently, the chopper should synchronize with the 3

GeV accelerator. In this paper, the timing control of whole JKJ accelerator complex and neutron beam chopper will be described.

### 2. Timing Control of 3 GeV Synchrotron

Because the 3 GeV synchrotron is a fast-cycling machine, the resonant network circuits will be employed for the bending and quadrupole magnet power supplies. The resonant frequency of each circuit is tuned at 25 Hz which is the repetition rate of the synchrotron, approximately. The frequency will be exactly controlled by the magnet power supply using the IGBT. For the control, the repetition rate frequency and the 3 GeV master trigger will be generated from the master clock of the JKJ accelerator complex. By this scheme, the timing of the top and bottom fields will be fixed respect to the master clock and master trigger. Because of high stability of the master clock ( $\Delta f/f=0.01\text{PPM}$ ), the accuracy of the timing will be mainly given by the stability of the power supply and it will be  $10^{-5}$ . The block diagram of the timing control for the 3 GeV Synchrotron is shown in Fig. 1. The timing chart is also shown in Fig. 2.

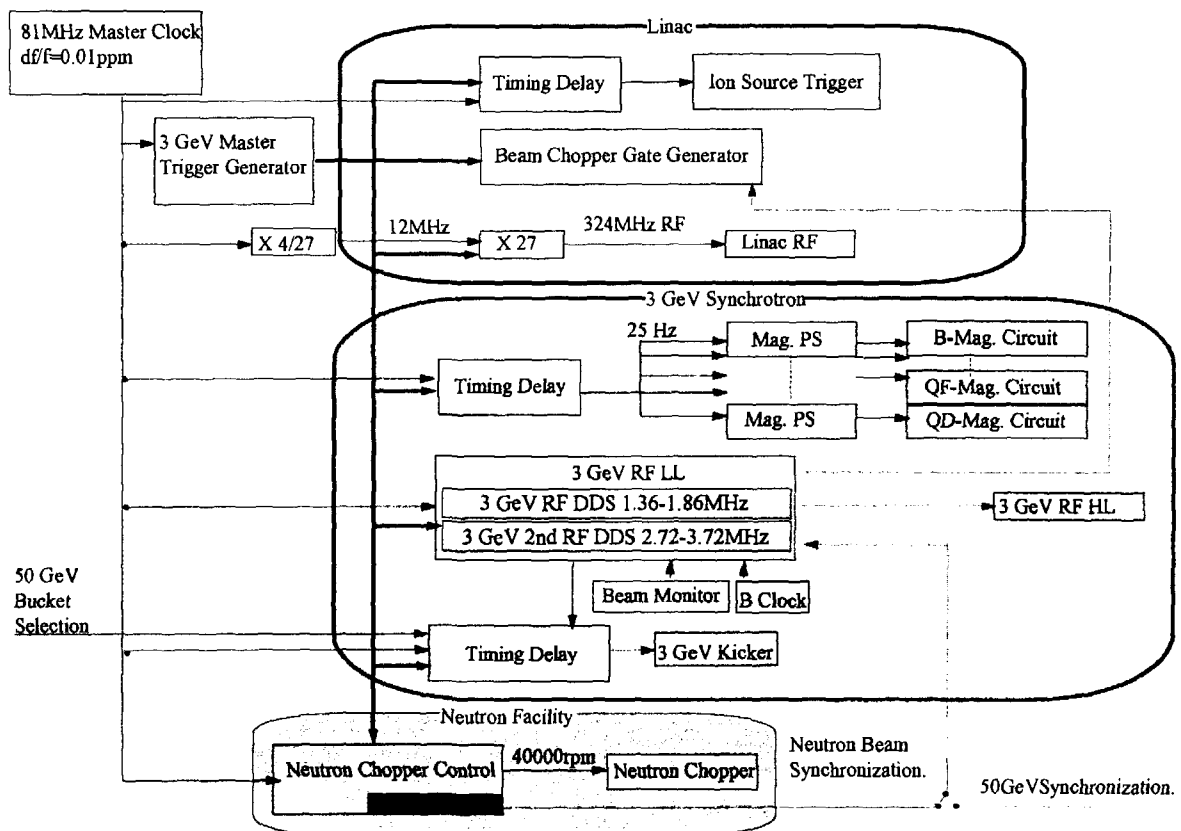

Figure 1. The block diagram of the 3 GeV timing control.

The radio-frequency signal is also generated from the master clock signal by using the DDS(Direct Digital Synthesis) technique. In order to generate the accelerating frequency

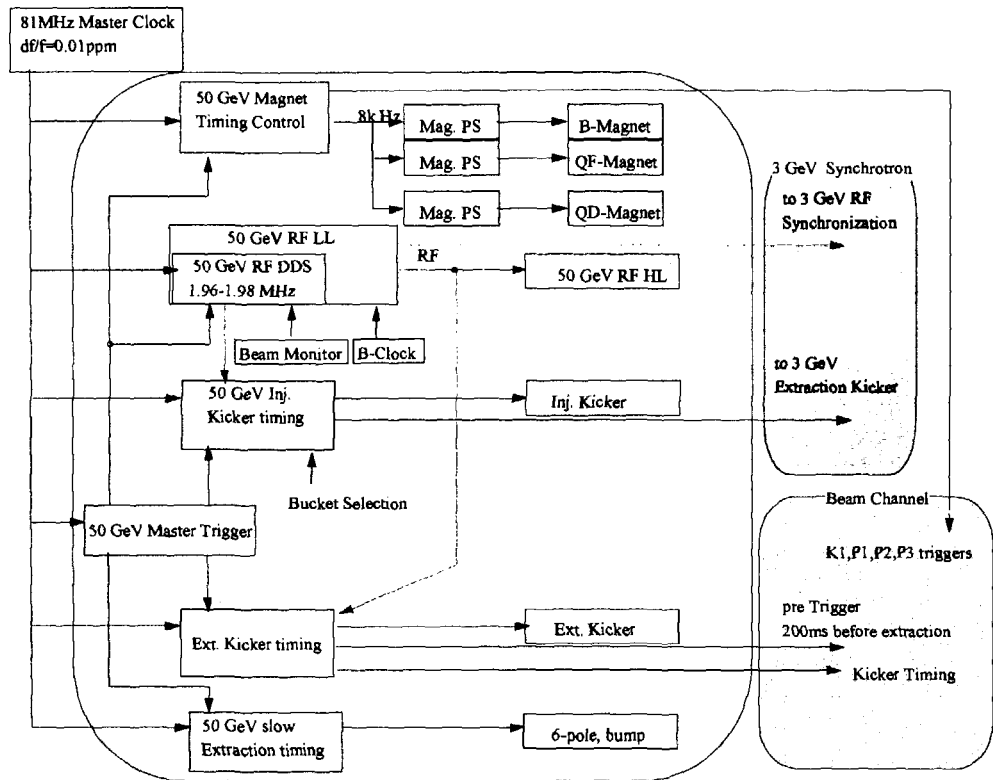

Figure 3. The block diagram of the timing control for the 50 GeV synchrotron.

#### 4. Synchronization between 3 GeV Synchrotron and Neutron Chopper

The neutron chopper is a heavy iron collimator which rotates at 40,500rpm. To cut the fast and slow neutron background, the beam extraction timing should be controlled at  $0.3 \mu\text{s}$  accuracy. Because the RF frequency is 1.86 MHz at the top, the synchronization between the beam and neutron chopper is necessary. And, the chopper gate should open when the beam has the top energy.

Because the resonant circuit will be used for the main magnets, the flat top of the magnetic field does not exist. However, the momentum change will be very small around the top energy, and it is only 0.1% during 0.9 ms. The rotation frequency of the chopper will be generated from the master clock and the time jitter from inertial moment of chopper should be small. The chopper and magnetic field will be synchronized anytime by this scheme.

To control the beam timing within  $0.3 \mu\text{s}$ , the RF phase will be synchronized to 1.86 MHz which is the frequency at the top and phase is adjusted to fit the chopper gate. The synchronization will start from several ms before the extraction. According to increase the feedback gain for the synchronization, the gain for the  $\Delta R$  (radial) feedback will be reduced. After the synchronization is established, the beam will be extracted when the chopper gate opens. The block diagram of synchronization between the 3 GeV synchrotron and neutron

range of 1.36-1.86 MHz and second harmonic one of 2.72-3.72 MHz, precisely, the master clock should be higher than 40 MHz. The master clock frequency of 81 MHz is chosen. And the half of the frequency will be used for the DDS because the system using the 40 MHz clock frequency is now available.

The linac RF and ion source will be controlled by the master trigger. The H<sup>+</sup> beam chopper which will cut the beam to fit it to the RF bucket of the 3 GeV synchrotron are located in the linac. The trigger for the chopper will be generated by the DDS and the master trigger.

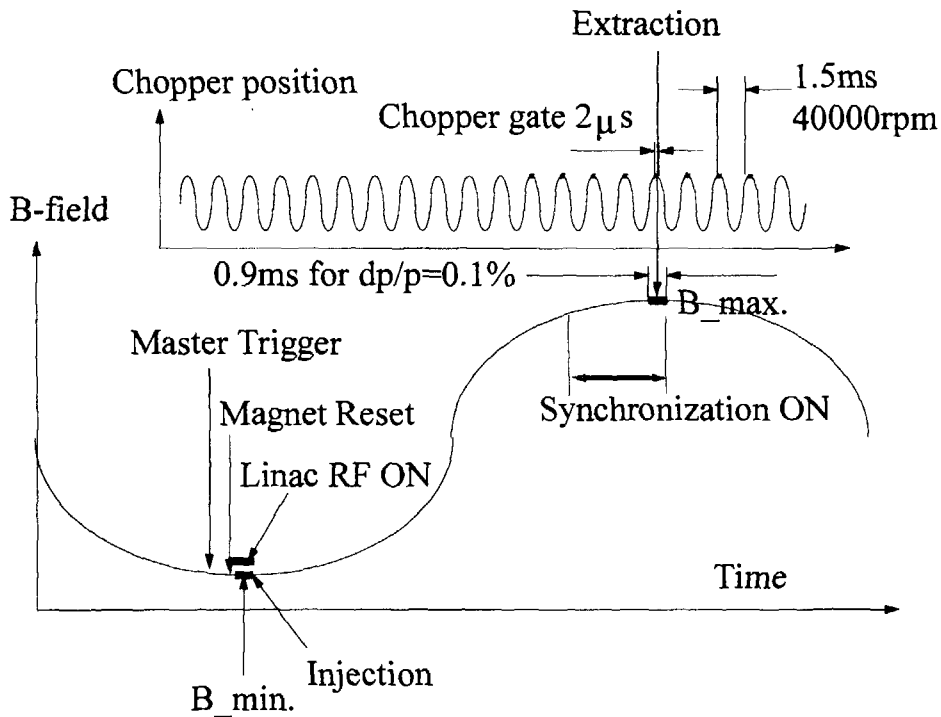

Figure 2. The timing chart of the 3 GeV synchrotron.

### 3. Timing Control of 50 GeV Synchrotron

The master clock scheme is also employed for the 50 GeV synchrotron. The magnet power supply using IGBT will be controlled by the 8 kHz clock produced from the master clock. The master trigger for 50 GeV synchrotron will be also produced and its repetition rate is 0.294Hz (3.4s). The block diagram of the timing control is shown in Fig. 2

The RF signal for 50 GeV synchrotron is generated from the master clock as like 3 GeV RF. For the neutrino experiment, a pre-trigger will be supplied at 200 ms before the fast extraction to set up the neutrino horn. The kicker timing and flat top timing are also supplied to the 50 GeV users.

chopper is shown in Fig. 1

### **5. Synchronization between 3 GeV and 50 GeV Synchrotrons**

Two beam bunches of the 3 GeV Synchrotron will be synchronized to the waiting buckets of the 50 GeV synchrotron before the extraction. The bucket selection and kicker magnets timing will be decided by the 50 GeV master trigger, master clock and 50 GeV RF DDS. The kicker timing will be sent to the 3 GeV extraction kicker and 50 GeV injection one.

### **References**

[1] JAERI/KEK Joint Project