

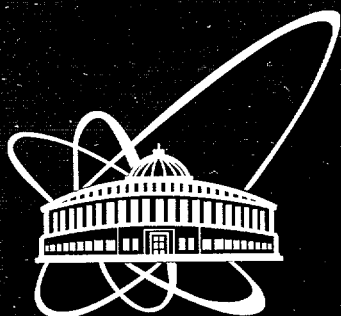

XJ0200080



**ОБЪЕДИНЕННЫЙ
ИНСТИТУТ
ЯДЕРНЫХ
ИССЛЕДОВАНИЙ**

Дубна

D13-2001-118

V.V.Perevozchikov*, A.A.Yukhimchuk*,
Yu.I.Vinogradov*, **M.D.Vikharev***, N.S.Ganchuk*,
A.N.Golubkov*, S.K.Grishechkin*, A.M.Demin*,
D.L.Demin, V.G.Zinov, A.A.Kononenko*, V.N.Lobanov*,
I.L.Malkov*, S.A.Yukhimchuk

DEUTERIUM HIGH PRESSURE TARGET

Submitted to «Приборы и техника эксперимента»,
Proceedings of the International RIKEN Conference
«Muon Catalyzed Fusion and Related Exotic Atoms»,
April 23–27 2001, Shimoda, Japan

*Russian Federal Nuclear Center — RFNC-VNIIEF, 607190, Sarov,
Nizhny Novgorod Region, Russia

.. 33 / 17

2001

INTRODUCTION

In regular investigations of muon catalyzed fusion in a high-dense deuterium, temperature range of 400-800K remained unexplored. Data on the formation rate of $dd\mu$ molecules are also necessary to analyze the results of experiments in a double D-T [1,2] and triple H-D-T [1,3] mixtures, where the rate of elementary processes $\lambda_{dd\mu}$ is extracted with regard to the calculated value of a mesomolecule $\lambda_{dd\mu}$ formation rate in deuterium. Experimental data on $\lambda_{dd\mu}$ value are only available over the temperature range to 400K [4,5,6].

Deuterium high-pressure target (DHPT) developed for direct $\lambda_{dd\mu}$ measurements in a temperature range of 80-800K meets the following requirements:

- working volume – 76 cm³;
- working pressure – to 150 MPa;
- operation temperature range – (80-800) K;
- direct or cryogenic compression of a working mixture;
- hydrogen strength;
- service life – not less than 400 hours under extreme operation conditions;
- strength reliability – $R \geq 0,99999$ at the confidence level of 0.95.

DHPT sufficiently exceeds the target described in [7] with the upper temperature limit without lowering of the value of the upper pressure limit.

DHPT DESIGN

DHPT (Fig. 1) represents a set of facilities, which allow to:

- generate diffusion-purified deuterium from thermodesorption metal hydride sources BS1, BS2 based on vanadium and uranium, respectively [8,9];
- cool down, heat and keep the given temperature of the target ampoule within 80 – 800K;
- fill the ampoule with deuterium at 80 – 300K.

Opposed to early-developed designs of tritium high-pressure targets (THPT) [10,11], DHPT's ampoule and cooler are structurally combined in one unit – the target unit (Fig. 2). As a result, dimensions of the target were reduced in vertical direction. The target may be used at 20 -800K, provided that liquid helium is used as a cooling agent. Design of the DHPT ampoule is similar to that of THPT [10], with the only difference in dimensions and design of the lower part. The deuterium contaminates in a cylindrical volume inside the ampoule the cylinder diameter is 31 mm and its height is 100 mm.

As in THPT, hydrogen - resistant alloy ХН40МДТЮ-ИД is used for basic load-bearing elements of the ampoule. Strength tests of the ampoule showed that its carrying capacity is 260 MPa that confirms its required strength reliability ($R \geq 0,999999$ with the confidence level 0.95). The cooler is a robust cryostat composed of the housing 2 and insert 3. These copper elements are tightly welded to one another. Upper and lower sides of the insert's surface A have ring slots C and B of rectangular form connected by helical grooves G. A special cavity D designed in the insert is filled with a gas (nitrogen, methane or carbon dioxide) and serves as a condensation thermometer. Connecting pipes 4 and 5, which join the cooler with external mains of a cooling agent supply and evacuation, are secured to the housing of the insert 3.

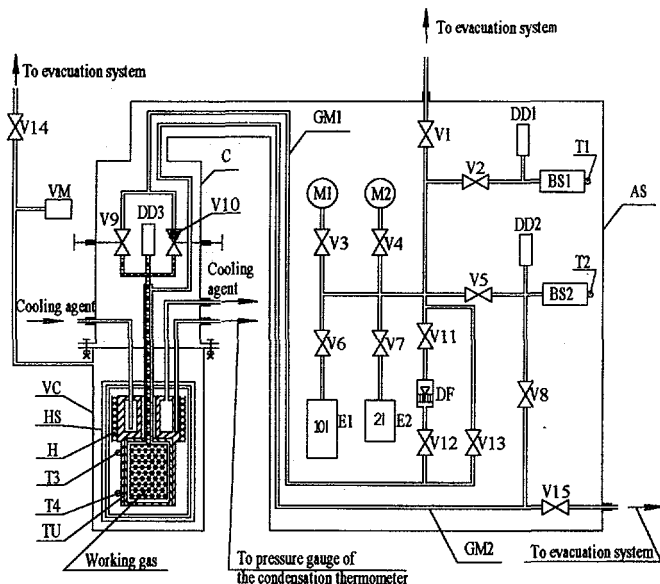

Fig. 1. Schematic drawing of DHPT: TU – target unit; VC – vacuum casing; C – cap; H – heater; T1...T4 – thermocouples; DD1, DD3 (0 – 250 MPa); DD2 (0 – 60 MPa) – pressure gauges; V1...V14 – valves; V15 – vacuum valve; VM – vacuum meter (PKR 261); M1 (0 – 1 MPa), M2 (0 – 25 MPa) – manometers; DF – diffusion filter; E1, E2 – measuring capacities; HS – heat – reflecting shields; BS1 – thermodesorption metal hydride vanadium – base source; BS2 – thermodesorption metal hydride uranium – base source; AS – assembly; GM1, GM2 – gas mains

To provide more uniform temperature distribution across the ampoule casing and effective heat transfer, the lower part of the cooler housing has a form of a cylindrical shell with a 1,5 mm wall thickness, which is placed on the ampoule E surface with an ensured tension, and fixed by uniformly - distributed welds.

Fig. 1 shows basic elements of DHPT providing its safe operation under high pressures and temperatures of a working gas. The target unit (TU) is installed in vacuum casing (VC), the inner cavity of which is evacuated by an external system. To minimize the content of metal in the way of the decay - electrons escape, the thinning was made on the body of this casing, in the area of a muon beam passage. Vacuum in the inner cavity of the casing is controlled by a vacuum meter.

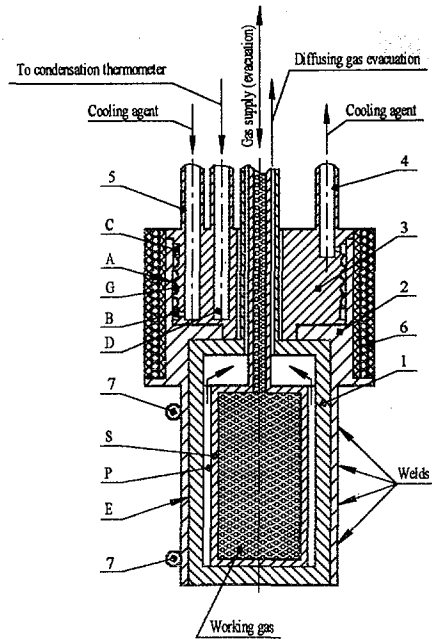

Fig. 2. Schematic drawing of the target unit: 1 – ampoule; 2 – casing; 3 – insert; 4,5 – connecting tubes; 6 – heater; 7 – thermocouples

For the personnel to be protected in the case of high-pressure equipment destruction, a cap C was placed on the upper part of the casing. High-pressure manually controlled valves V9 and V10, strain pressure gauge DD3 and high-pressure gas main GM1 for a working gas supply and evacuation are located under the cap. Valves V9 and V10 provide the shutoff of the ampoule inner cavity as soon as it is filled with a working gas. Valves controls are arranged beyond the outer surface of the cap. To heat the ampoule to required temperature, a heater (H) is put on the body of the target unit (TU) enclosed in a set of 6-layer radiation heat - reflecting shields (HS). The shields reduce required power of the heater under stationary conditions, ensure rather uniform temperature distribution over the ampoule casing and prevent the heating above 70°C of the casing's outer surface.

GAS SUPPLY SYSTEM

Gas supply system is intended for deuterium supply into the ampoule of the target unit at up to 150 MPa and for its evacuation after experiments. Besides it allows measuring the amount of a working gas in the ampoule. The system consists of the sources BS1 and BS2, diffusion filter DF, manometers M1 and M2, measuring capacities E1 and E2, pressure gauges DD1 and DD2, thermocouples T1 and T2, gas mains and valves. It is made as a separate assembly (AS) representing a support housing all of the above elements. Outer surfaces of the support

are coated by protective materials. Gas mains GM1 and GM2 between the assembly and the cap are enclosed in a protective shell made of a metal pipe.

Deuterium sources based on uranium and vanadium hydrides are used in DHPT. The sources are of a similar design and differ only in the employed working material – gas carrier. Schematic drawing of the source is shown in Fig. 3.

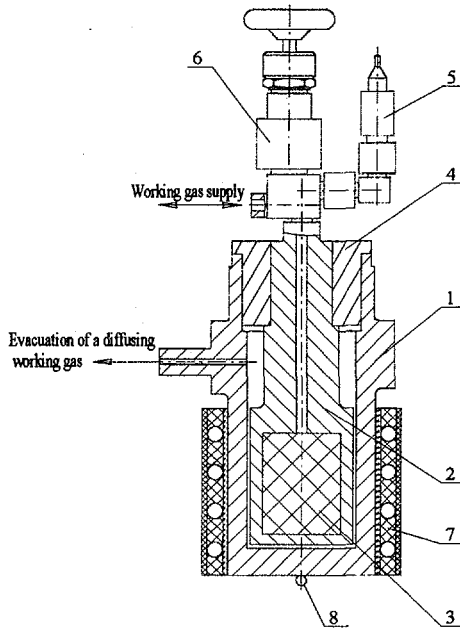

Fig. 3. Schematic drawing of the source: 1 – outer case; 2 – inner case; 3 – metal hydride (working gas carrier); 4 – sealing cap; 5 – pressure gauge; 6 – high-pressure valve; 7 – heater; 8 – thermocouple

On heating, the uranium-base source allows removing more than 99 % of its gas, and when cooling to a room temperature, residual pressure in the ampoule of the target will be $\approx 3,5 \cdot 10^{-4}$ Pa (equilibrium vapor pressure upon uranium hydride) [12,13]. Therefore upon completion of the test, this source may be used for actually complete gas evacuation from the mains and the target ampoule. This very source may be also employed to absorb deuterium diffusing through the walls of the target unit in the course of the target heating. In that way a set of experiments completely closed by gas may be realized. However, the uranium-base source cannot produce the pressure needed to fill the ampoule. Pressure produced by uranium deuteride is shown in Fig. 4 as a function of its heating temperature (line 1).

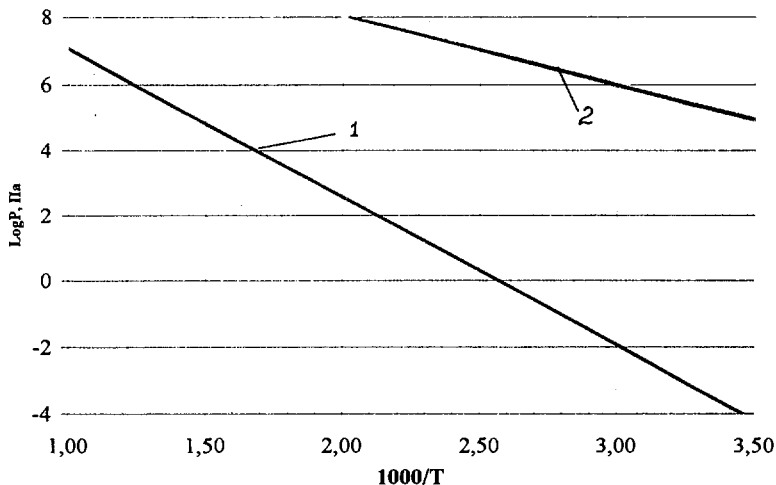

Fig. 4. Temperature dependence of the pressure produced by uranium (1) and vanadium deuterides (2)

At high temperatures strength properties of structural steels used in the manufacture of the source BS2 deteriorate significantly, therefore its heating area is limited to $\approx 970\text{K}$. Fig. 4 shows that at such temperature it can produce a pressure of no more than $\approx 7,5\text{MPa}$. Further pressure in the ampoule may be increased by its heating, provided that it was filled to cryogenic temperatures, or using another source (vanadium-base source BS1). Vanadium hydride is known as one of the most suitable hydrogen carrier for the development of high-pressure sources [14,15]. Of all metal hydrides it has the largest value of the volumetric specific gas content – $8,5 \cdot 10^{-2}$ mole H_2/cm^3 of hydride, as well as high values of the hydrogen isotopes equilibrium pressure upon hydride at relatively low temperatures. Equilibrium pressure of deuteride upon vanadium deuteride is shown in Fig. 4 as a function of temperature (line 2) [16]. It is clear from Fig. 4 that vanadium – base source of deuterium on heating is capable of producing 150 MPa already at $\approx 520\text{K}$. Therefore, with this source any working pressure may be easily produced in the ampoule irrespective of its temperature. Disadvantage of vanadium deuteride is relatively high equilibrium pressure of deuterium upon it at room temperature ($\approx 6,6 \cdot 10^{-4}$ Pa). So, with this source it is difficult enough, following the target filling, to perform rather full evacuation of the gas remained in the mains; this may be better done using uranium – base source.

COOLING SYSTEM

Design of the target unit's cooler (Fig. 2) allows using liquid nitrogen or helium. Depending on the employed cooling agent (nitrogen or helium) the target cools down to 80K or 20K. A cooling agent is delivered and evacuated by a special thermostatic system [17]. The target temperature is controlled by the cooling agent consumption within accuracy $\pm 3\text{K}$. A cooling

agent is fed into the cooler through the main attached to connecting pipe 5 having outlet into the volume of the lower ring slot B of the insert 3. From the indicated cavity a cooling agent through helical channels G enters the volume of the upper ring slot C followed by the cooling agent evacuation through the main secured to connecting pipe 4. Geometry of the housing's parts and gas channels of the cooler have been selected so that to meet required thermophysical characteristics.

HEATING SYSTEM

Design of the heater presented in Fig. 2 is similar to that used in THPT [10]. It provides for the ampoule heating and the maintenance of the target ampoule's temperature from 300 to 800K, accurate within ± 1 K. To ensure service reliability, the heater is made of two independent heating elements each of 250 W. The power of one element is sufficient to keep the temperature of the ampoule casing over entire operation temperature range. Electric parameters of the heater are controlled by the automated monitoring and control system (MCS) of DHPT.

MONITORING AND CONTROL SYSTEM

MCS of DHPT meets the requirements for its safe and reliable operation. It represents a distributed network composed of the central computer and a set of autonomous network modules. The following smart devices are used to collect data from sensors and to control regulation units: remote analog and discrete In/Out (ICP DAS) modules with interface RS - 485; and two-channel controller TPG - 256 (Balzers Instruments) with interface RS - 232.

MCS includes:

- thermocouple for measuring the temperature of sources and working gas in the inner cavity of the target ampoule;
- strain pressure gauges;
- vacuum meter;
- electron power controllers for sources heater and filter;
- electron power controllers for the target heaters.

MCS provides for:

- measurement and control over the working gas pressure and temperature in the inner cavity of the target unit's ampoule;
- control and monitoring over the working gas temperature and pressure in thermodesorption metal hydride sources;
- control and monitoring of the diffusion filter temperature;
- vacuum measurement in the inner cavity of the casing;
- representation of all measured parameters in a real time ;
- save all measured parameters for subsequent processing and analysis.

The working gas pressure in the inner cavity of the target unit's ampoule and in thermodesorption metal hydride sources is registered by strain pressure gauges with the upper measurement limit to 250 MPa (calibration error is 3 %).

Vacuum in the casing (C) inner cavity (Fig. 1) is controlled by PKR 261 meter (Balzers Instruments) having measurement range of $5 \cdot 10^{-4} - 10^3$ mbar.

Temperature of the working gas in the inner cavity of the target unit's ampoule is controlled by thermocouples T3 and T4, which are in direct contact with the housing of the indicated unit. When determining the working gas temperature in the inner cavity of the ampoule,

it is assumed that with a steady static mode, temperature of the ampoule casing approaches the temperature of this gas with a good accuracy. Thermocouples are made from "thermocouple" wire graded "chromel - nickel".

Temperature of the target unit's body and, consequently, working gas within the range below room temperature is also measured by the condensation thermometry method. The method consists in the registration of the gas pressure change of the in-cavity placed cooler D (Fig. 2) depending on the temperature. Nitrogen, methane or carbon dioxide are used as a condensed gas depending on the temperature of the target unit, pressure in the indicated cavity may reach 6 MPa. Gas state parameters are registered by the autonomous system, which is not included in DHPT. With the target ampoule temperature higher than the room temperature, cavity D is evacuated by a fore vacuum pump.

Thermocouples T1 and T2 are used to register the work gas temperature in sources BS1 and BS2. Their design is similar to that of the thermocouples employed in temperature control of the work gas in the inner cavity of the target unit's ampoule. With the use of thermocouples, temperature is registered by a multichannel analog- input module I - 7018 (ICP DAS), which allows measuring thermo- e.m.f. of the thermocouple in a temperature range from -200 to $+1300^{\circ}\text{C}$ with the accuracy of 0.05 %. Ultimate instrument error of the temperature measurement is as follows: at -200°C - $\pm 5.6^{\circ}\text{C}$, at 0°C - $\pm 4^{\circ}\text{C}$, and at $+600^{\circ}\text{C}$ - $\pm 5.6^{\circ}\text{C}$.

Pressure and temperature in the ampoule of the target unit and sources is continuously controlled by MCS. If limiting values of these parameters are exceeded, heaters' power of these units is automatically turned off.

OPERATION OF DHPT

Before experiments, all gas mains of DHPT (Fig. 1) are evacuated to residual pressure at least 10^{-4} mbar (if necessary using temperature annealing). Upon reaching this pressure, the ampoule of the target unit is cooled to needed temperature. Then diffusion filter DF is heated to the working temperature ($450 - 500^{\circ}\text{C}$) with its continuous evacuation from two sides. Thereafter, the source BS2 is heated to the temperature, which provides 6 MPa pressure of a working gas in the source. Gas generated by this source enters into the inner cavity of the target ampoule through filter DF. Heating of the source BS2 is terminated upon completion of the filling.

Simultaneous filling of the target ampoule with deuterium and additional filling of the source BS1 is possible. The source BS1 is responsible for the ampoule target filling within the pressure range 6 - 60 MPa. This source may be also used for filling with deuterium of the target ampoule up to 150 MPa through a bypass line omitting filter DF. On reaching required pressure in the target ampoule its filling is terminated (BS1 heating is stopped) and the target is exposed or its temperature rises to the value specified by the experiment.

Deuterium remained in gas mains after the filling is adsorbed by the source BS2. As soon as the gas is fully adsorbed by the above source, heating of the filter DF is stopped.

During the test of muon catalysis at high temperatures and pressures deuterium diffusing from the ampoule inner cavity through its first wall S into the cavity P (Fig.2) is evacuated from the target unit through the main GM2. There are two regimes for the diffusing deuterium evacuation: the first is to evacuate deuterium onto uranium source BS2, the second - pumping by the external evacuation system.

After experiments, the gas is evacuated from the target ampoule. There are two ways of evacuation: directly onto sources BS1 and BS2, or first to capacity E1 (E2) and then to the

source BS2. Second variant of evacuation is employed if it is necessary to measure quantity of the gas, which was in the target ampoule during the test.

OPERATION RESULTS

250 - hour cryogenic and functional tests of the target as well as experiments on muon channel of the LNP JINR phasotron showed that DHPT offers the following technological parameters:

- it takes 2 hours to cool the ampoule casing from room temperature to 80K ;
- generation and liquefaction of maximum amount of diffusion-pure deuterium of 0.85 LHD density (density of liquid hydrogen) lasts 3 hours;
- heating from 80 to 800K is accomplished for three hours;
- losses of the working gas due to diffusion are not more than 5 % for 10 hours at maximal operation temperature 800K and 150 MPa pressure.

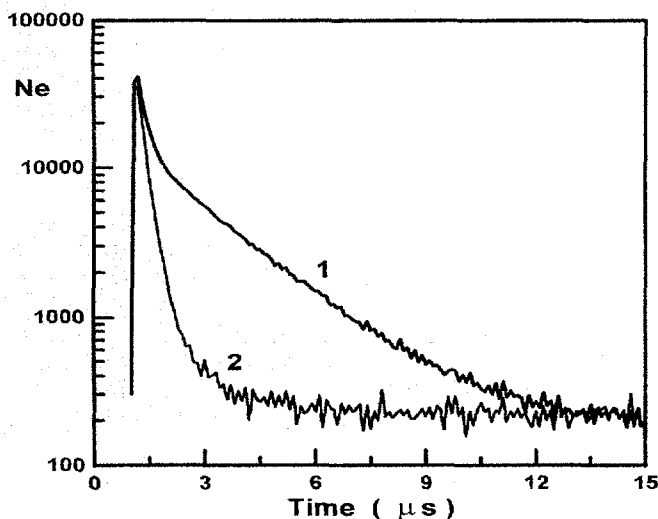

Fig. 5. Electron decay time spectrum: 1) target filled with deuterium; 2) empty target

Analysis of the spectrum of electrons induced by the decay of muons - (Fig. 5), stopped in the target, showed that the target design and used structural materials allow effective nuclear - physical measurements of muon catalyzed fusion.

CONCLUSION

Design and technological capacity of DHPT allowed running a set of experiments (150 hours) on muon channel of the LNP JINR, during which parameters of muon catalyzed fusion in diffusion - purified deuterium were determined for the first time at temperature 400 - 800K and pressure up to 150 MPa.

The authors are grateful to all specialists and personnel of the plant RFNC - VNIIEF who took an active part in DHPT development and refinement, as well as to the staff of RFNC - VNIIEF and JINR for the assistance in lifetime, functional and cryogenic tests of DHPT. The authors also appreciate the help of V.M. Pershina in the elaboration of design documents and N.N. Grafov, V.G. Grebinnik, A.P. Kustov, M.M. Petrovsky in the experimental runs. The authors express special thanks to the Corresponding Member of RAS L.I. Ponomarev for his valuable assistance.

The work has been performed with financial support of the RF Ministry for Atomic Energy (agreement # 6.25.19.19.00.969).

REFERENCES

1. V.R. Bom, J.N. Bradbury, J.D. Davies et al. // *Hyperfine Interactions* 118 (1999) 103.
2. V.R. Bom, J.N. Bradbury, J.D. Davies et al. // *Communications JINR*, E15-2000-157, Dubna, 2000.
3. V.R. Bom, J.N. Bradbury, J.D. Davies et al. // *Communications JINR*, E15-2000-156, Dubna, 2000.
4. C. Petitjean, D.V. Balin, W.H. Breunlich et al. // *Hyperfine Interactions* 118 (1999) 127.
5. V.P. Dzhelepov, V.G. Zinov, S.A. Ivanovsky et al. // *Zhurn. Eksp. i Teor. Fiz* 101, Issue 4 (1992) 1105.
6. V.V. Filchenkov and L. Marczis // *Muon Cat. Fusion* 5/6 (1990/1991) 499.
7. V.M. Bystritsky, V.B. Granovsky, V.P. Dzhelepov et al. // *Prib. i Techn. Eksp.* 1(1989)50.
8. A.A. Yukhimchuk, V.A. Apasov, Yu. I. Vinogradov et al. // *Instruments and Experimental Techniques*, Vol. 42, No 6 (1999) 747.
9. S.K. Grishechkin, A.A. Kononenko, V.V. Perevozchikov et al. // *A radiation - safe container for D - T filling of laser targets*, J. Moscow Phys. Soc. 9 (1999) 289;
10. V.V. Perevozchikov, A.A. Yukhimchuk, D.L. Demin et al. // *Instruments and Experimental Techniques*, Vol. 42, No 1 (1999) 25.
11. V.V. Perevozchikov, A.A. Yukhimchuk, N.S. Ganchuk, et al. // *Tritium high-pressure targets for research in muon catalyzed fusion. Proceedings of the International Workshop "Potential of the Russian Nuclear Centers and ICTC in Tritium Technologies"*, Sarov, 2000, p.114.
12. V.I. Mikheeva // *Hydrides of transition metal*, AS USSR, M., 1960/
13. K. Makkey // *Hydrogen metal compounds*, Mir, M., 1968.
14. A.N. Golubkov, A.A. Yukhimchuk // *Sources of gaseous high - pressure hydrogen isotopes*. J. Moscow Phys. Soc. 9 (1999) 223.
15. D.H.W. Carstens and W.R. David // *Use of vanadium dihydride for production of high - pressure hydrogen gas*. Proc. Int. Symposium on metal Hydrogen Systems, Miami, Florida, 1981, p.667. Ed. By T.N. Veziroglu.
16. A.N. Golubkov, S.K. Grishechkin, A.A. Yukhimchuk // *Facility to study interaction processes between hydrogen isotopes and solid body at about 500 MPa*. In: *VI International Conference «Hydrogen materials Science & Chemistry of Metal Hydrides»*, Yalta, Ukraine, September 02-08, 1999, Abstracts book of NATO International Conference, p.257.
17. D.L. Demin, V.P. Dzhelepov, N.N. Grafov et al. // *Hyperfine Interactions* 101/102(1996) 583; Preprint JINR P13-95-179, Dubna, 1995.

Received by Publishing Department
on June 4, 2001.

**SUBJECT CATEGORIES
OF THE JINR PUBLICATIONS**

| Index | Subject |
|--------------|---|
| 1. | High energy experimental physics |
| 2. | High energy theoretical physics |
| 3. | Low energy experimental physics |
| 4. | Low energy theoretical physics |
| 5. | Mathematics |
| 6. | Nuclear spectroscopy and radiochemistry |
| 7. | Heavy ion physics |
| 8. | Cryogenics |
| 9. | Accelerators |
| 10. | Automatization of data processing |
| 11. | Computing mathematics and technique |
| 12. | Chemistry |
| 13. | Experimental techniques and methods |
| 14. | Solid state physics. Liquids |
| 15. | Experimental physics of nuclear reactions at low energies |
| 16. | Health physics. Shieldings |
| 17. | Theory of condensed matter |
| 18. | Applied researches |
| 19. | Biophysics |

**The Publishing Department
of the Joint Institute for Nuclear Research
offers you to acquire the following books:**

| Index | Title |
|---------------|---|
| D1,2-98-215 | Proceedings of the International Workshop «Relativistic Nuclear Physics: from MeV to TeV». Dubna, 1998 (384 p., in English and Russian) |
| E2-98-254 | Proceedings of the International Workshop «Hadronic Atoms and Positronium in the Standard Model». Dubna, 1998 (260 p., in English) |
| D9,11-98-273 | Proceedings of the 4th International Workshop «Beam Dynamics and Optimization». Dubna, 1997 (162 p., in English and Russian) |
| E17,19-98-305 | Proceedings of the International Workshop on Deuteration of Biological Molecules for Structural and Dynamic Studies. Applications to Neutron Scattering and NMR. Dubna, 1998 (100 p., in English) |
| E1,2-98-307 | Proceedings of the International School-Seminar «Actual Problems of Particle Physics». Gomel, Belarus, 1997 (2 volumes, 304 p. and 220 p., in English) |
| E2-98-372 | Proceedings of the III International Workshop «Classical and Quantum Integrable Systems». Erevan, 1998 (200 p., in English) |
| E9-99-26 | Proceedings of the International Conference on High Energy Accelerators. Dubna, 1998 (432 p., in English) |
| E2-99-35 | Proceedings of the XI International Conference on Problems of Quantum Field Theory. Dubna, 1998 (508 p., in English) |
| E9-99-92 | Proceedings of the XVII International Conference on High Energy Accelerators HEACC'98. Dubna, 1998 (435 p., in English) |
| E9,18-99-169 | Proceedings of the International Symposium SCHEF'99 «Space Charge Effects in Formation of Intense Low Energy Beams». Dubna, 1999 (209 p., in English) |
| E7,17-99-199 | Proceedings of the Research Workshops «Nucleation Theory and Applications». Dubna, 1997, 1998, 1999 (510 p., in English) |
| E3-99-212 | Proceedings of the VII International Seminar on Interaction of Neutrons with Nuclei. Dubna, 1999 (372 p., in English) |
| D1,2-99-294 | Proceedings of the International Workshop «Relativistic Nuclear Physics: from MeVs to TeVs». Stara Lesna, Slovak Republic, 1999 (192 p., in English and Russian) |
| D2-99-310 | Proceedings of the Seminar «Symmetries and Integrable Systems». Dubna, 1999 (317 p., in English and Russian) |
| D9-2000-69 | Proceedings of the III Scientific Seminar in Memory of V.P.Sarantsev. Dubna, 1999 (196 p., in English and Russian) |
| E15-2000-75 | Proceedings of the IV International Workshop «Laser Spectroscopy on Beams of Radioactive Nuclei». Posnan, Poland, 1999 (262 p., in English) |

- E2-2000-82 Proceedings of JINR Workshop «Supersymmetries and Quantum Symmetries». Dubna, 1999 (454 p., in English)
- E1,2-2000-166 Proceedings of the XIV International Seminar on High Energy Physics Problems «Relativistic Nuclear Physics and Quantum Chromodynamics». Dubna, 1999 (2 volumes, 256 p. and 320 p., in English)
- E2-2000-172 Proceedings of the International Seminar «Physical Variables in Gauge Theories». Dubna, 1999 (172 p., in English)
- E3-2000-192 Proceedings of the VIII International Seminar on Interaction of Neutrons with Nuclei. Dubna, 2000 (460 p., in English)
- E1,2-2000-208 Proceedings of the International School-Seminar «Actual Problems of Particle Physics». Gomel, Belarus, 1999 (2 volumes, 196 p. and 206 p., in English)
- D2,5-2000-218 Proceedings of the International School «Symmetries and Integrable Systems». Dubna, 1999 (158 p., in English and Russian)
- E2-2000-226 Proceedings of the V International Workshop «Heavy Quark Physics». Dubna, 2000 (154 p., in English)
- E1,2-2000-244 Proceedings of the International Workshop on Very High Multiplicity Physics. Dubna, 2000 (204 p., in English)
- E1,2-2000-248 Proceedings of the Second International Symposium «LHC Physics and Detectors». Dubna, 2000 (3 volumes, in English)
- E1,2-2000-282 Proceedings of the International Workshop «Hot Points in Astrophysics». Dubna, 2000 (406 p., in English)
-

Please apply to the Publishing Department of the Joint Institute for Nuclear Research for extra information. Our address is

Publishing Department
Joint Institute for Nuclear Research
Dubna, Moscow Region
141980 Russia
E-mail: publish@pds.jinr.dubna.su

Перевозчиков В.В. и др.
Дейтериевая мишень высокого давления

D13-2001-118

Приведена конструкция дейтериевой мишени высокого давления объемом 76 cm^3 для исследования процессов мюонного катализа ядерных реакций синтеза в диффузионно-чистой дейтерии в диапазоне температур 80–800 К при давлениях до 150 МПа.

Изложены принципы работы основных систем мишени: генерации и очистки газа, охлаждения, нагрева, вакуумирования, управления и автоматизированного сбора данных.

Работа выполнена в Лаборатории ядерных проблем им. В.П.Джелепова ОИЯИ.

Препринт Объединенного института ядерных исследований. Дубна, 2001

Perevozchikov V.V. et al.
Deuterium High Pressure Target

D13-2001-118

The design of the deuterium high-pressure target is presented. The target having volume of 76 cm^3 serves to provide the experimental research of muon catalyzed fusion reactions in ultra-pure deuterium in the temperature range 80–800 K under pressures of up to 150 MPa.

The operation of the main systems of the target is described: generation and purification of deuterium gas, refrigeration, heating, evacuation, automated control system and data collection system.

The investigation has been performed at the Dzhelepov Laboratory of Nuclear Problems, JINR.

Preprint of the Joint Institute for Nuclear Research. Dubna, 2001

Макет Т.Е.Попеко

Подписано в печать 05.07.2001
Формат 60 × 90/16. Офсетная печать. Уч.-изд. л. 1,88
Тираж 190. Заказ 52760. Цена 2 р. 25 к.

Издательский отдел Объединенного института ядерных исследований
Дубна Московской области