

E9-2013-99

V. L. Smirnov, N. S. Azaryan, S. B. Vorozhtsov

PRELIMINARY PARAMETER ASSESSMENTS
OF A SPIRAL FFAG ACCELERATOR
FOR PROTON THERAPY

Смирнов В.Л., Азарян Н.С., Ворожцов С.Б.

E9-2013-99

Предварительные оценки параметров спирального ускорителя FFAG для протонной терапии

Кольцевой фазотрон (FFAG) был изобретен в 50–60-х гг. прошлого столетия. Однако в то время работы по его созданию не продвинулись дальше модельных исследований. Начиная с 2000 г. вновь возник интерес к этому типу ускорителей. С учетом преимуществ FFAG по сравнению с синхротроном, циклотроном и линейным ускорителем возникло множество предложений по его применению. Среди прочего нас заинтересовали возможности ускорения протонов и легких ионов для протонной терапии. В связи с этим были проведены предварительные оценки параметров установки и, в частности, расчеты магнитного сектора и динамических характеристик магнитного поля ускорителя. Кроме того, были сформулированы предварительные соображения по проектированию ВЧ-системы установки.

Работа выполнена в Лаборатории ядерных проблем им. В.П.Джелепова ОИЯИ.

Сообщение Объединенного института ядерных исследований. Дубна, 2013

Smirnov V. L., Azaryan N. S., Vorozhtsov S. B.

E9-2013-99

Preliminary Parameter Assessments of a Spiral FFAG Accelerator for Proton Therapy

Fixed-Field Alternating-Gradient (FFAG) accelerator was invented in the 1950–60s but never progressed beyond the model stage. Starting from 2000, new interest in this type of accelerator arose. Given advantages of the FFAG over the synchrotron, cyclotron and linac, there are many possible applications of the accelerator. Among them, we are mostly interested in acceleration of protons and light ions for hadron therapy. In this connection a preliminary set of parameters of the facility was estimated and, in particular, the magnetic sector shape and corresponding dynamical properties of the magnetic field of the accelerator were calculated. In addition, preliminary considerations about the RF system design are given.

The investigation has been performed at the Dzhelepov Laboratory of Nuclear Problems, JINR.

Communication of the Joint Institute for Nuclear Research. Dubna, 2013

INTRODUCTION

As the latest estimates indicate, the number of patients who need proton and hadron therapy steadily grows. Given the situation, construction of reliable, inexpensive and simple-in-service medical accelerators looks important. One of the candidates is a FFAG (Fixed-Field Alternating-Gradient) accelerator that has a number of advantages over cyclotrons and synchrotrons, which are usually used in medicine at present.

The FFAG accelerator was invented in the 1950–60s [1,2], but never progressed beyond the model stage. Starting from 2000, new interest in this type of accelerator was explained by successful commissioning of two radial sector accelerators in Japan: 1 MeV POP (proof of principle) and 150 MeV FFAG for acceleration of protons [3]. Now, there are two operational proton FFAG accelerators, namely, KEK [3] and KURRI [4]. Also, there are several machines under design and construction, e.g., RACCAM [5] and PAMELA [6]. Surprisingly, there is practically no activity in this direction in Russia (except a few publications, see, for example, [7]), despite the fact that the FFAG principle was initially proposed in this country [1].

In this work, a preliminary design study of a spiral dipole and accelerating RF cavity for a quasiscaling [8] FFAG accelerator is described. The corresponding dynamical properties of the magnetic field of the facility were also estimated. The lattice properties are presented as a result of it. The machine is supposed to replace the JINR Phasotron (Dubna, Russia), that is now heavily used for medical applications [9].

1. MEDICAL APPLICATION ISSUES

Being fast cycling machines, FFAGs can deliver a very high dose rate, e.g., 5 Gy/min in 1 l volume and potentially far beyond with protons, in the space-charge free regime [10]. The accelerator allows slice-to-slice energy variation and thus 3D conformational irradiation techniques [5]. Also, bunch-to-bunch energy variation gives access to 3D tumour motion tracking. FFAG has the following technical advantages:

- Use of nonpulsed power supplies.
- Simple RF system.
- Multiparticle capability.
- Possibility of multiport extraction.
- Easier construction and operation, high performance and reliability, low maintenance, and hence lower treatment cost as a result of fixed field.

Specifications for this type of machine can be formulated using, as a starting point, the requirements from [5] related to the RACCAM accelerator for the 70–180 MeV proton beam.

2. MACHINE OVERVIEW

The majority of the proton therapy treatments would be carried out with proton energy of 230 MeV. Thus, this energy was chosen for the design of the machine. Figure 1 shows a general scheme of the accelerating setup. Figure 2 shows possible location of FFAG in the JINR Phasotron vault.

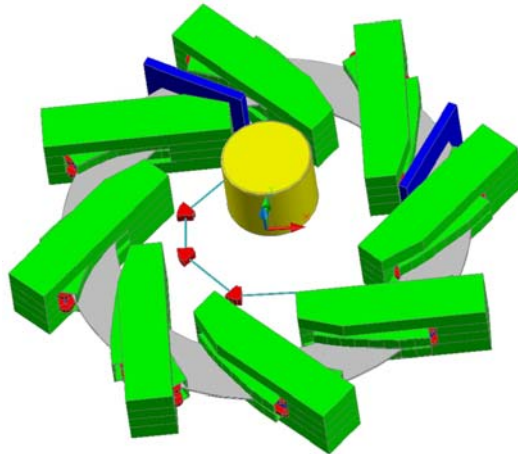

Fig. 1. General layout of the JINR FFAG with the H-injector cyclotron included

There are two competitive accelerator magnet sector designs, radial [4] and spiral [5]. A spiral type of FFAG provides a more compact layout. Beam energy can be varied either by the synchronized kicker or by changing the magnetic field in the FFAG magnets. The latter will devoid the machine fixed-field advantages and, due to this, requires careful investigation for justification. An injector can be a standard H-compact cyclotron like the MCC-30/15 [11] commercially produced by NIEFA, St. Petersburg, Russia. The main parameters of the accelerator are given in Table 1.

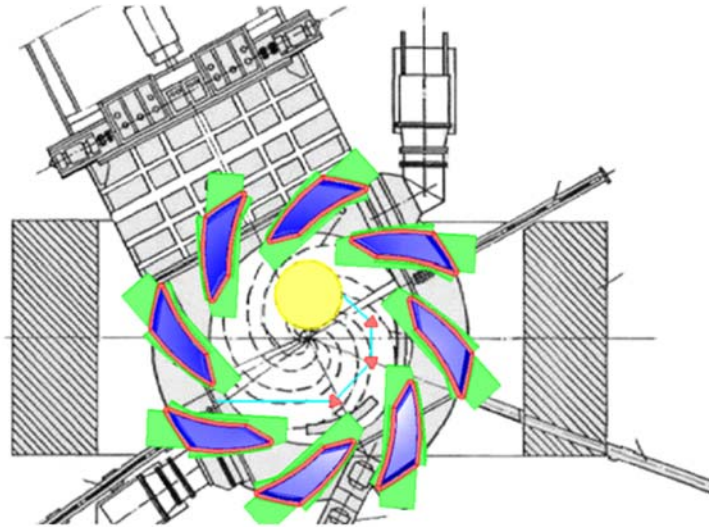

Fig. 2. Possible location of FFAG in the JINR Phasotron vault

Table 1. Main parameters of the accelerator

Parameter	Value
Particle	Proton
Type	Quasi-scaling, spiral
Packing factor	0.32
Number of cells	8
Extraction energy, MeV	70–230
Injection energy, MeV	30
Intensity	> 100
Extraction efficiency, %	> 90
Average radius of max/min orbit, m	3.58/4.24

3. MAGNET DESIGN

The compactness of the proton therapy complex makes the spiral magnet sector a preferable choice. The basic feature of the scaling FFAG accelerator is constancy of the betatron tunes throughout the acceleration process. This requires a magnet design that ensures constant field index $k = \frac{r}{B} \frac{dB}{dr}$ in the whole radial working range. The field index was chosen to be large enough to limit the radial

beam excursion from injection to extraction orbits. On the other hand, k should be small enough to keep the magnet spiral angle below $\sim 55^\circ$ to avoid the problems of magnetic field nonlinearity. As a result, the spiral angle of 50° was selected. Another condition requires that the working point on the tune diagram will be away from the dangerous resonance lines.

The pole profile should be such that the magnetic field increases as

$$B(r) = B_0 \left(\frac{r}{r_0} \right)^k. \quad (1)$$

It can be achieved with the gap variation inversely proportional to (1), i.e.,

$$g(r) = g_0 \left(\frac{r_0}{r} \right)^k, \quad (2)$$

where $B_0 = 0.31$ T (approximately), $r_0 = 3920$ mm, and $g_0 = 100$ mm are the reference mean field, radius, and gap, respectively.

The main parameters of the spiral sector are given in Table 2.

Table 2. Spiral sector main parameters

Parameter	Value
Type	Spiral
Design field index	5.6
Spiral angle, deg	50
Sector angle, deg	14.5
Max. field on orbit, T	1.67
Ampere-turns/pole, kA	36.7
Size, L \times W \times H, m	4 \times 1 \times 1.6
Weight, t	50

The basic principles of the spiral sector design [12, 13] are as follows.

The selected pole profile of the magnet should provide field index constancy.

The sector edges are chosen to compensate fringe field effects and keep constant radial (horizontal) tune Q_r .

The flutter and spiral angle variation with radius should compensate for the axial (vertical) tune Q_z shift caused by the radius dependence of the effective fringe width.

The shaping of the sector geometry does not require strict constancy of betatron tunes (quasi-scaling condition). The main goal was to prevent crossing dangerous resonances during the acceleration process. It was important to obtain the sector shape as simple as possible, for example, without additional facets, etc.

A typical gap shaping method was reduced to ensuring a constant k along the central sector line followed by variation of the edge geometry to minimize the difference between the theoretical and the computed effective azimuthal length of the field. This will lead to almost constant Q_r function of radius. In this work, we pursue obtaining such a vertical gap variation with radius that provides constant horizontal betatron tune over the working radial range, but not a constant field index value along the central line. This approach takes into account the effect of

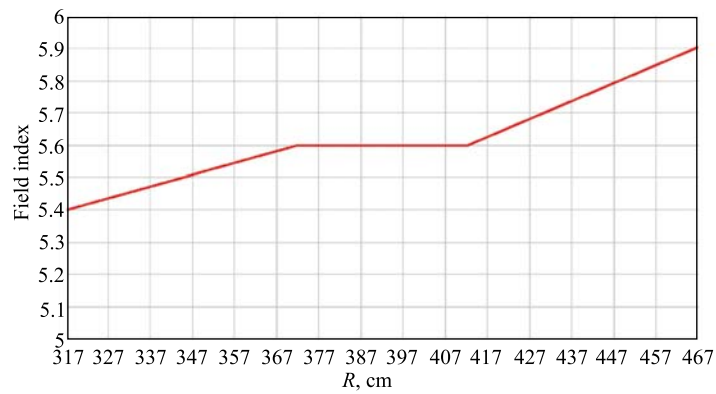

Fig. 3. Proposed k variation with radius

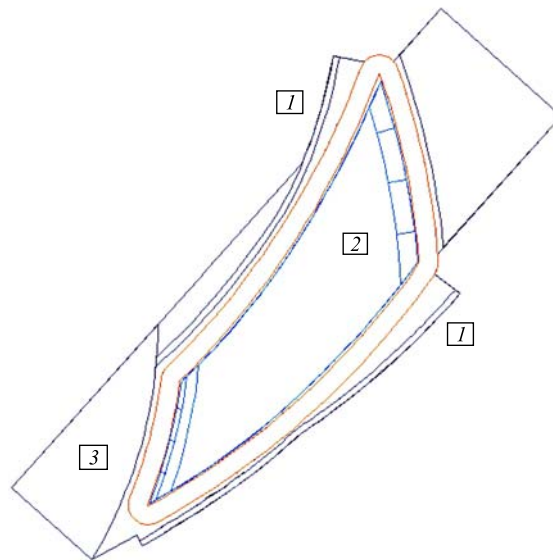

Fig. 4. Spiral sector: 1 — clamps, 2 — pole, 3 — yoke

the fringe fields on the betatron tune. As a result, it allows keeping Q_r constant for the pole profile as in (2) with compensation of the fringe field effects by linear k variation, with k being smaller than the design value at injection and larger at extraction. In the radial range 3.17–4.67 m, the vertical gap should be calculated with the k values from Fig. 3.

There are two possible methods for improving the Q_z constancy.

Introduction of the coil clamps in the computer model of the sector to shape the fringe field.

Fine correction of the spiral angle at selected radii for both sides of the pole contour.

The clamps (Fig. 4) can reduce the effective length of the fringe field thus controlling the fringe field integral along the orbit. The reduction of the effective fringe field length will increase the field flutter leading to the corresponding Q_z shift.

There is a variable gap between the clamps and the coil that increases with radii. This will compensate an increase in the flutter in this area without clamps.

Final correction of the vertical betatron tune is performed by changing the spiral angle along the radius by a few degrees, see Fig. 5.

Betatron tunes (Fig. 6) were calculated by the well-known CYCLOPS program [14] and the SNOB particle tracing code [15]. Some uncertainties of the results can be explained by unavoidable fluctuations of the calculated magnetic field. The working point in the tune diagram (Fig. 7) was chosen such as to avoid crossing dangerous resonances. In this process both internal and imperfection resonances were taken into account. The horizontal phase advance per cell is

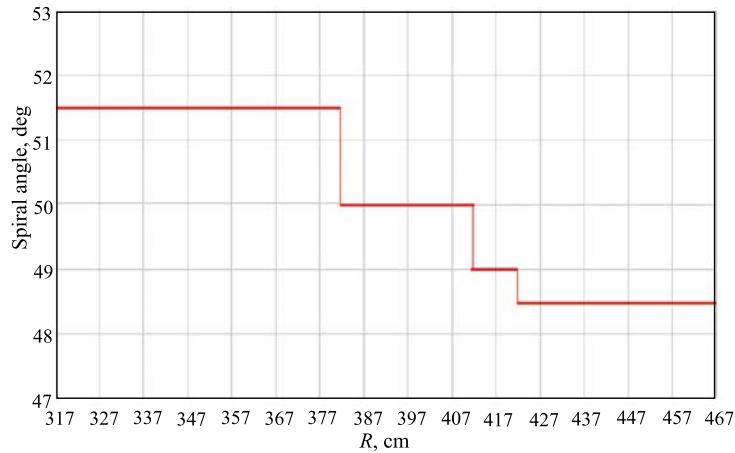

Fig. 5. Sector spiral angle vs. radius. Actually, at the location of the vertices the spiral angle is smoothed in the computer model and in the resulting field distribution in the midplane of the magnet

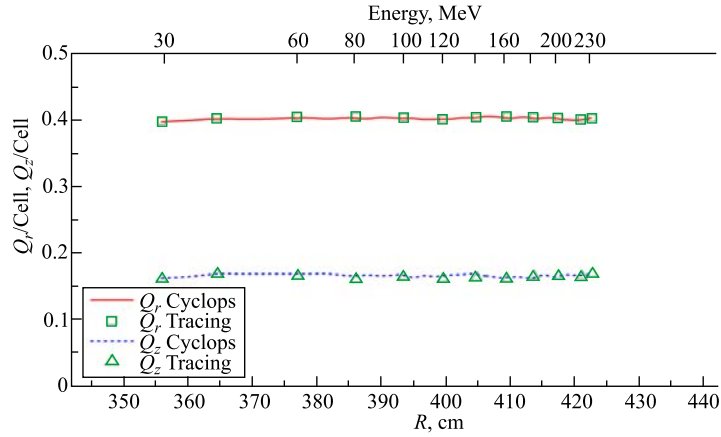

Fig. 6. Horizontal and vertical tune per cell

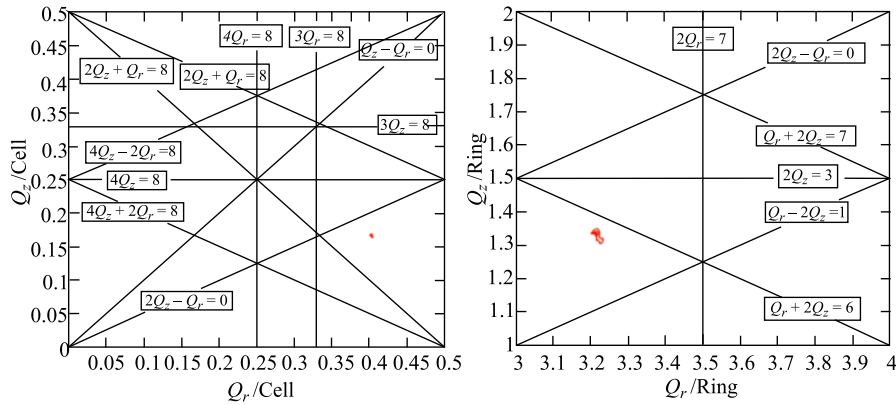

Fig. 7. Tune diagrams

taken to be close to 135° in order to have two structure cells between the kicker and the septum at beam extraction.

The magnetic field calculation for the determination of the pole profile was performed by the VF Opera-3D code without the preliminary 2D field calculations, as is usually done. It took about 15 iterations to arrive at the final result. To save computer time, a slightly reduced number of finite elements (FEs) were used in the calculations, which resulted in ~ 3 h per iteration. But for the final iteration a minimal possible FE mesh spacing was used for smoothing fluctuation amplitudes in the magnetic field map.

The above-described preliminary design stage of the magnet dipole permits performing analysis of the dynamic properties of the magnetic field.

4. PRELIMINARY CONSIDERATIONS ABOUT THE RF SYSTEM DESIGN

A FFAG needs an accelerating RF system with frequency variation. Two types of such accelerating structures are well known. One is the so-called «rot-co» — a variable capacitor, which is mechanically actuated to change its capacity for tuning the resonant frequency of the cavity. A real example of this RF system with frequency variation from ~ 18 to ~ 14 MHz is the accelerating structure of the JINR Phasotron [9].

It is also possible to tune the resonance frequency of the cavity by changing the inductivity of the RF circuit using an electromagnetic tuner. In this type of accelerating structure ferrites are used for tuning by applying a bias magnetic field to the cavity. Also, the use of ferrites automatically reduces the size of the cavity. A disadvantage of ferrite-loaded cavities is power dissipation in the ferrite and, as a result, a low Q -factor of several tens.

This type of cavity (Fig. 8) is very widely used in synchrotrons [16–18]. They generally operate below 10 MHz with a typical range of frequency variation of 2–3 within 500 ms. A possibility of using the ferrite-loaded cavity for the FFAG accelerator is described in detail in [19].

The KEK machines introduced important innovations in both the magnet and RF design. The RF innovation was to load the cavities with amorphous and nanocrystalline metallic alloy (MA) materials, which have a high permeability and allow a higher induction than ferrites. The MA cavities are based on the principles similar to those of classical ferrite cavities but with fewer MA cores needed, which leads to a more compact design. A significant feature of these accelerating structures is a low Q -factor (≈ 1 or less) which means that these RF systems have a wide bandwidth that permits working without frequency tuning. In this case the tuning loop and the feed-back system are not needed.

A good candidate for material for a high-gradient MA cavity is FINEMET, which has high permeability, high saturation magnetic-flux density (Fig. 9), and

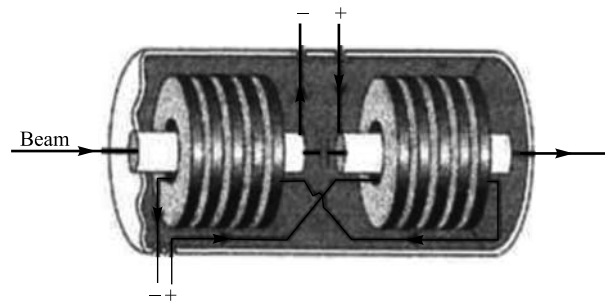

Fig. 8. Typical structure of a ferrite-loaded cavity [17]

high Curie temperature [20,21]. FINEMET was developed by Hitachi Metals Ltd. [22].

FINEMET is an amorphous metal ribbon of 18 μm thick (see Fig. 10), consisting of Fe, Si, B, and small amounts of Cu and Nb. The ribbon is wound into a toroidal core and annealed in a nitrogen atmosphere to increase magnetic properties by making crystals small, of the order of 10 nm. The amorphous core acquires excellent magnetic properties and is called a FINEMET core.

To confirm the ability of the constructed computer model to adequately represent the RF system functionality, the simulations were twice cross-checked by (i) simulating the HIRFL-CSR RF cavity [23] and (ii) calculating the RACCAM FFAG RF cavity [24]. The authors of [24] use the Q -value of the MA cores measured at a frequency of 1 MHz and represented as $Q = 1/\tan \delta_{\text{mag}}$. So,

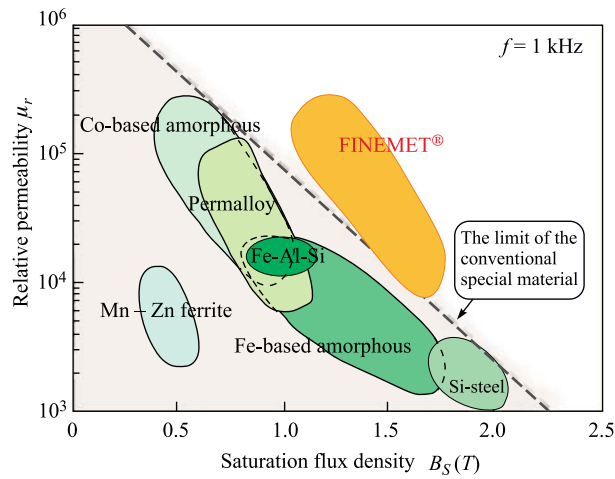

Fig. 9. Relationship between relative permeability and saturation flux density for various magnetic materials [22]

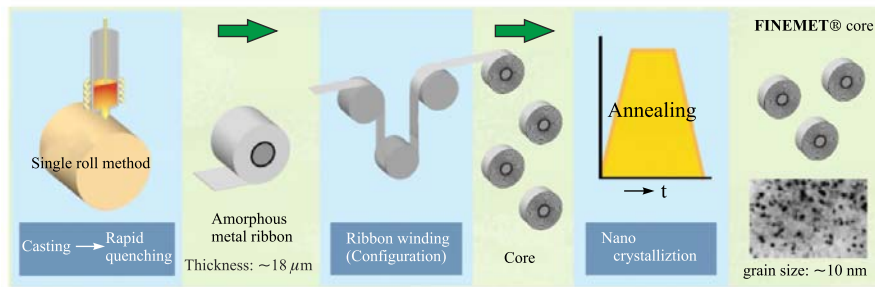

Fig. 10. Production of FINEMET [22]

we take the geometry from that work, $Q = 0.781$ and $\mu' = 1570$, and obtain the fundamental frequency of the cavity 1.561 MHz in our 3D simulation against 1.57 MHz in [23]. We are very grateful to the authors of this paper, who provide with us some details of their work.

The second cross-check was made to elaborate a method of calculation of Q -factor of our MA cavity that is similar to the RACCAM RF structure described in [24]. To describe the dispersion of $\tan \delta_{\text{mag}}(f)$, we use the dependences of $\mu'(f)$ and $\mu''(f)$ for FINEMET FT-1 (see Fig. 11):

$$\tan \delta_{\text{mag}}(f) = \frac{\mu''}{\mu'}(f).$$

We obtain $Q = 0.68$ against 0.6 in [24]. Both of our cross-check simulations were made with a rather low accuracy, but the results are encouraging. The requirements on the accelerating system of our FFAG are similar to those in the RACCAM project, and for the initial design we take the RF cavity [25] as a basis. It consists of a copper frame with two FINEMET cores inside that are fixed by fiberglass (see Figs. 12 and 13).

The accelerating gap is tilted by about 5° for reducing the angle between the electric field vector and the beam orbit. This is needed because the cavity position is not perpendicular to the beam trajectory due to spiral structure of the magnets (see Figs. 1, 2 and 15).

As is seen in Figs. 1, 2 and 15 spiral magnets do not allow one to put the cavities perpendicular to beam orbits and by this case a radial component of

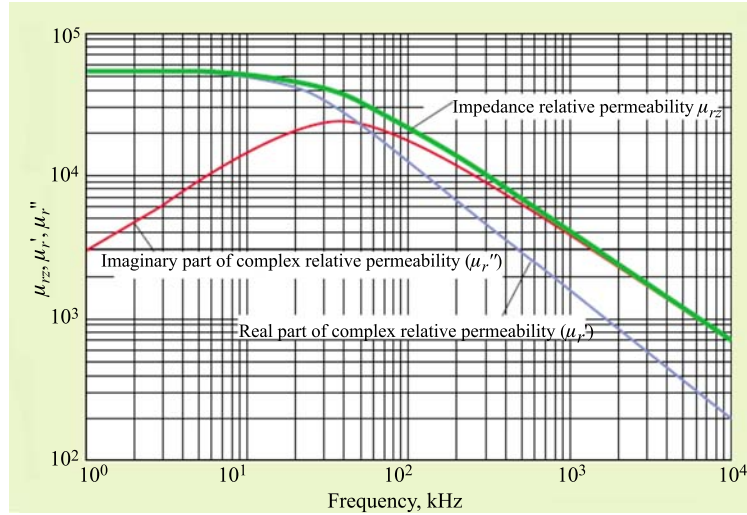

Fig. 11. Complex permeability of FT-1M FINEMET [22]



Fig. 12. Design of the MA cavity for the JINR FFAG (top view)

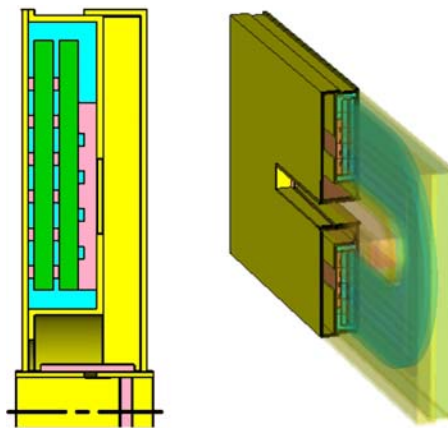

Fig. 13. Design of the MA cavity for the JINR FFAG (side view and axonometric projection)

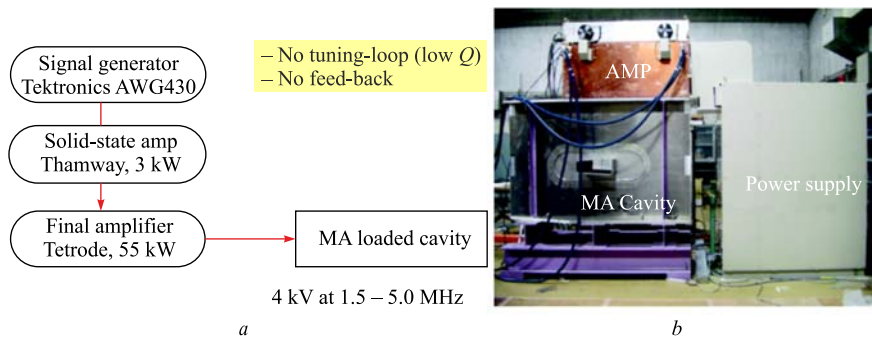

Fig. 14. Power supply of the MA cavity: *a*) RF assembly for PRISM [26]; *b*) scheme of the KURRI RF system [27]

electric field is exist. To reduce the angle between the vector of accelerating field and beam trajectory, the accelerating gap is tilted by about 5° .

Parameters of the RF system for the JINR FFAG are presented in Table 3 in comparison with the parameters of the RACCAM RF system.

Table 3. Parameters of the RF systems

Parameter	RACCAM [24, 25]	JINR FFAG
Injection energy, MeV	5.5–15	30
Extraction energy, MeV	70–180	70–230
RF frequency, MHz	1.86–7.54	3.25–6.64
Repetition rate, Hz	102–169	> 100
Harmonic number	1	1
Number of gaps	1	1
Length, m	0.2	0.2
Beam excursion, m	0.667	0.666
Size of cavity, m	$2.0 \times 1.2 \times 0.2$	$2.8 \times 1.3 \times 0.2$
Beam pipe, m	0.83×0.13	1.3×0.12
Core size, m	$1.7 \times 1.0 \times 0.03$	$2.4 \times 1.2 \times 0.03$
Core aperture, m	1.0×0.3	1.6×0.4
Core material	FINEMET	FINEMET
Q -factor	0.6	0.6
Peak RF voltage	3 kV	3 kV
Power density in core	< 0.5 W/cc	
Amplifier output power	25.0 kW	
Amplifier operation class	Class AB	
Amplifier plate voltage	6 kV	
Amplifier anode current	10:00 AM	
Tetrode	RS1084CJ	

Examples of power supply of MA cavities are presented in Fig.14. It is more suitable to directly connect the tetrode amplifier to the cavity. Impedance matching is not mandatory if the amplifier is located close to the cavity. Short cables have to be used since they contribute to the overall impedance/capacitance. The cavity and RF power amplifier should be assembled as a single unit [18].

5. BEAM DYNAMICS

Some preliminary results of the particle tracing are shown in Fig. 15, where static closed orbits are depicted against the accelerator structure. The number of turns of particles for the regime of 30–230 MeV is ~ 24000 with the RF voltage peak of 6 kV and two RF cavities. Motion of particle with initial axial displacement was simulated to ascertain the stability of the axial oscillations (see Fig. 16).

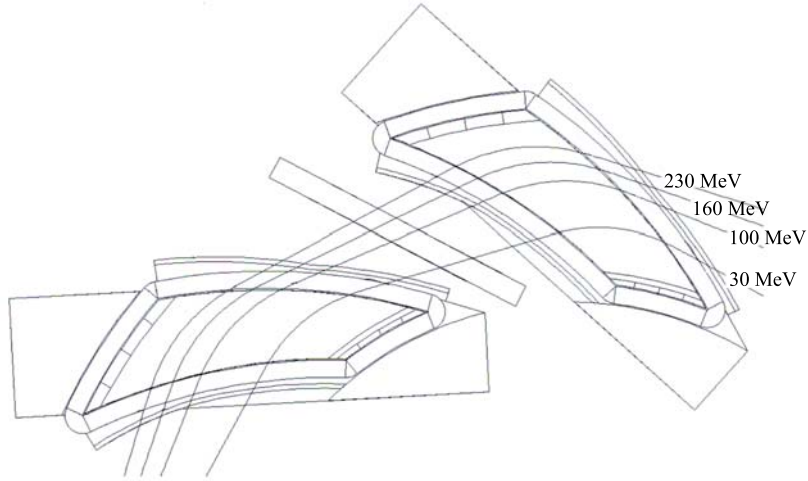

Fig. 15. Closed orbits

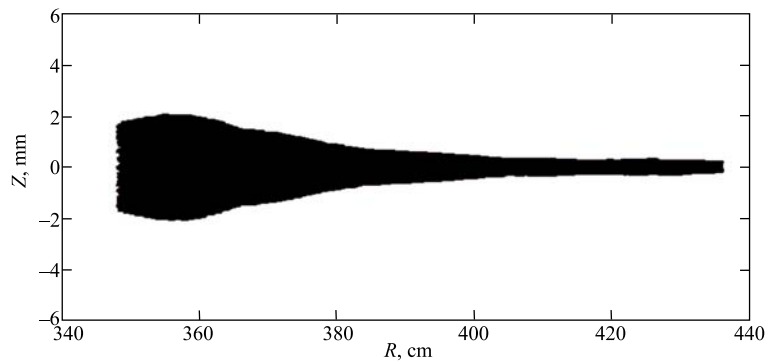

Fig. 16. Axial motion of the particle with initial axial displacement

6. CONCLUDING REMARKS

Further activities comprise: dynamical aperture assessment, bunch acceleration, RF system design, injection H-cyclotron choice, injection and extraction system design outline, cost estimation.

REFERENCES

1. Kolomensky A. A., Petukhov V. A., Rabinovich M. S. Lebedev Physical Institute Reports, 1953.
2. Ohkawa T. Bull. Phys. Soc. Jpn. 1953.
3. Adachi T. et al. A 150 MeV FFA Synchrotron with Return-Yoke Free Magnet // Proc. of the 2001 PAC, Chicago, USA. P. 3254–3256.

4. *Sato Y. et al.* Development of FFAG Proton Synchrotron // Proc. of the EPAC 2000, Vienna, Austria, 2000. P. 581.
5. *Antoine S. et al.* Principle Design of a Proton Therapy, Rapid-Cycling, Variable Energy Spiral FFAG // Nucl. Instr. Meth. Phys. Res. A. 2009. V. 602. P. 293–305.
6. *Yokoi T.* Status of Pamela: an UK Particle Therapy Facility Project Using NS-FFAG // Intern. J. Mod. Phys. A. 2011. V. 26, Nos. 10, 11. P. 1887–1902.
7. *Dmitrievsky V.P. et al.* FFAG Synchrocyclotron as a Booster for Linac // Proc. of the 4th Eur. Particle Accelerator Conference (EPAC 1994), London, UK, 27 June–1 July 1994. P. 572.
8. *Craddock M.K.* FFAG Optics // Intern. Workshop on FFAG Accelerators (FFAG'11). FFAG School. Daresbury Laboratory, England. September 2011.
9. *Onischenko L.M.* JINR Phasotron // Proc. of the 1987 IEEE Particle Accelerator Conference. Accelerator Engineering and Technology. March 16–19, 1987. Washington, D.C., USA. P. 878.
10. The application of FFAG Synchrotrons in Hadrontherapy. Workshop organized by the RACCAM project, Centre Anti-Cancer Antoine Lacassagne, Nice, France, November 2007. http://lpsc.in2p3.fr/service_accelerateurs/raccam.html
11. *Vorogushin M.F.* NIIIEFA Accelerators for Industry and Medicine // Proc. of RUPAC 2012, St. Petersburg, Russia. P. 167–171.
12. *Planche T. et al.* Design of a Prototype Gap Shaping Spiral Dipole for a Variable Energy Proton Therapy FFAG // Nucl. Instr. Meth. Phys. Res. A. 2009. V. 604. P. 435–442.
13. *Qin B. et al.* Design of High Energy Hadron FFAGs for ADSR and Other Applications // Proc. of CYCLOTRONS 2010, Lanzhou, China. P. 269–271.
14. *Gordon M.M.* // Part. Accel. 1984. V. 16. P. 39.
15. *Smirnov V.L., Vorozhtsov S.B.* SNOP — Beam Dynamics Analysis Code for Compact Cyclotrons // Proc. of the XXI Russian Accelerator Conference (RuPAC'2012), St. Petersburg, Russia, 2012. P. 325–327.
16. *Chao A.W., Tigner M.* Handbook on Accelerating Physics and Engineering. World Scientific, 1999. P. 520–522.
17. *Gardner I.S.K.* Ferrite Dominated Cavities. CERN Accelerator School 1991. RF Engineering for Particle Accelerators. CERN-92-03-V1-V2. P. 349–374.
18. *Klingbeil H.* Ferrite Cavities. CERN Accelerator School 2010. RF for Accelerators. CERN-2011-007. P. 299–317.
19. *Zaplatin E.* FFAG RF System Study. Technical Note. Berlin, 1993.
20. *Ng K.Y., Qian Z.B.* Finemet Versus Ferrite — Pros and Cons // PAC'1999, New-York, USA. 1999. P. 872–874.
21. *Yuichi Morita.* Development of a New RF Accelerating Cavity Loaded with Magnetic Alloy Cores Cooled by a Chemically Inert Liquid for Stabilizing and Enhancing the Performance of J-PARC Ring Accelerator. PhD Thesis, 2011.
22. Nanocrystalline Soft Magnetic Material FINEMET. Hitachi Metals Ltd., 2005.
23. *Mei L.R. et al.* MA Cavity for HIRFL-CSR // IPAC'11, San Sebastian, Spain, 2011. P. 125–127.
24. *Ohmori C. et al.* High Field Gradient RF System for a Spiral FFAG, RACCAM // EPAC'08, Genova, Italy, 2008. P. 793–795.

25. *Ohmori C. et al.* RF System for RACCAM FFAG // PAC'09, Vancouver, Canada, 2009. P. 873–875.
26. *Ohmori C.* MA Cavities. PRISM Workshop. Imperial College, London, UK, 2009.
27. *Uesugi T. et al.* RF of KURRI FFAG Main Ring // FFAG 2011 Workshop. Trinity College, Oxford, UK, 2011.

Received on September 4, 2013.

Корректор *Т. Е. Попеко*

Подписано в печать 20.01.2014.

Формат 60 × 90/16. Бумага офсетная. Печать офсетная.

Усл. печ. л. 1,18. Уч.-изд. л. 1,59. Тираж 215 экз. Заказ № 58162.

Издательский отдел Объединенного института ядерных исследований
141980, г. Дубна, Московская обл., ул. Жолио-Кюри, 6.

E-mail: publish@jinr.ru

www.jinr.ru/publish/